

**Universal Dual Unit Rack Mount Kit****Introduction**

This instruction sheet contains the parts list and installation information for the Keithley Instruments Model 4299-3 Universal Dual Unit Rack Mount Kit. This kit includes all hardware necessary to mount two half-rack instruments (either a Keithley Instruments or Agilent unit), excluding the Keithley Instruments Series 2600 or other products that are designed to use the rear-support feature in a standard 19-inch rack.

**Parts list**

Table 1 lists the parts supplied with the Model 4299-4 Universal Dual Unit Rack Mount Kit.

Table 1  
**Model 4299-4 part listing**

Quantity	Description	Keithley Instruments part number
2	Hinge	2602-328
2	Front rack ear	2602-355
1	Modified quick-release pin	FA-352
4	Cage nut	FA-274
1	"DO NOT DISCARD" label	MC-345
4	#8-32 x 3/8 LG Phillips pan-head screw	8-32X3/8PPH
4	#8-32 x 3/8 LG Phillips flat-head screw	8-32X3/8PFH
4	#10-32 x 5/8 LG Phillips truss-head screw	10-32X5/8PHTRSH
4	M4 x 12 Phillips pan-head screw	M4X12PPH
4	M4 x 12 Phillips flat-head screw	M4X12MMPFH

**Installation**

The following procedure outlines the installation of the rack-mount kit.

**WARNING** *Make sure the instrument that is being installed is in a powered down state with all cables unplugged. Failure to install an instrument in a discharged state may cause an electrical shock or death.*

**CAUTION** Place the hottest equipment (for example, the power supply) at the top of the rack.

Place precision equipment as low as possible in the rack (where temperatures are cooler).

Follow instructions included with Keithley Instruments equipment for rack mounting.

---

**NOTE** 1U is a standard vertical spacing and is equal to 1.75 inches. Typical distance between the mounting holes on rack rails is 0.125 inches (1/8 inch).

---

## Step 1: Prepare the instrument

To prepare the instrument for mounting, remove the handle, the mounting ears, and both rear feet. The following information outlines this process:

1. Remove the handle. The handle serves as an adjustable tilt-bail. Adjust its position by gently pulling it away from the sides of the instrument case and swinging it up or down. To remove the handle, swing the handle below the bottom surface of the case and back until the orientation arrows on the handles line up with the orientation arrows on the mounting ears (see Figure 1). With the arrows aligned, pull the ends of the handle away from the case.

Figure 1  
**Remove handle and mounting ears**

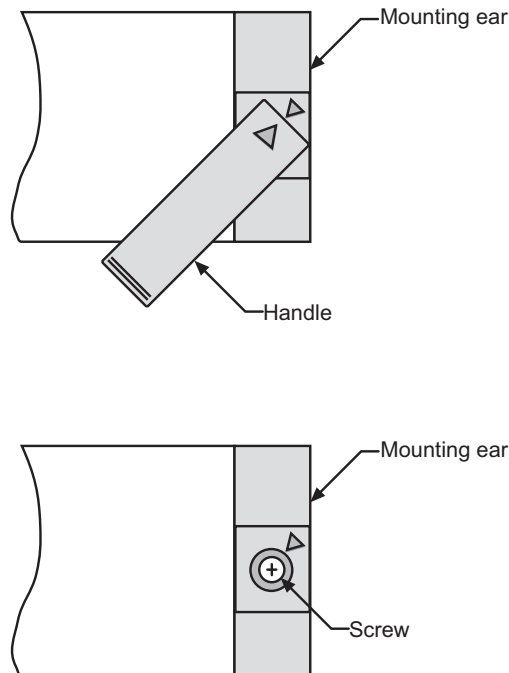

2. Remove mounting ears.
  - Remove the screw that secures each mounting ear.
  - Pull down and out to remove each ear.
3. Remove both rear feet from the instrument by pulling out the rubber feet and then removing the screws underneath.

---

**NOTE:** Do not reinstall the feet mounting screws. Save all parts removed for future bench-top use of the instrument.

---

## Step 2: Install mounting hardware on instrument

**NOTE** The instrument may be installed on the rack's right side with the half-rack front panel on the left side, as shown in the following illustrations, or on the rack's left side with the half-rack front panel on the right side (not shown).

1. Determine and select the unit's side that is to be installed closest to the rack rail (see note above).
2. Place the instruments side-by-side as they will be installed in the rack (see Figure 2).
3. Secure front rack ear (2602-355) using two pan-head screws (see Figure 2).

**NOTE** Knuckles on the hinge (2602-328) must face the front of the units being installed.

Figure 2  
Attach rack ear and hinge to instrument

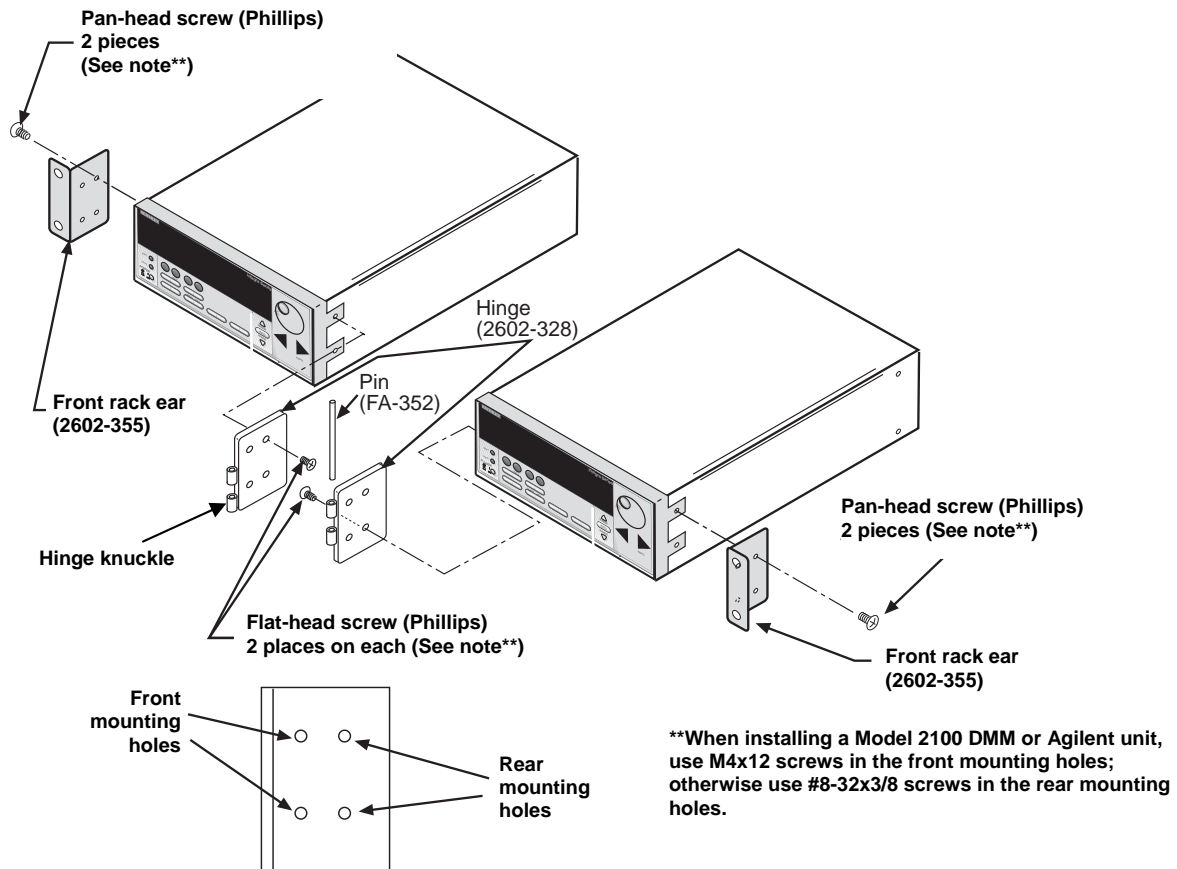

4. Secure one-half of the hinge to the right instrument and the other half of the hinge to the left instrument, using two flat-head screws on each half. Check knuckle orientation on hinges; knuckles must face the front of the units.
5. Bring the two instruments together and secure by inserting the pin (FA-352) to assemble the hinge.

### Step 3: Prepare the rack

Install the cage nuts (FA-274) into the front rack holes for the front rack ear and the half-rack front panel (see Figure 3).

---

**NOTE** Cage nuts for the front rack ear, half-rack front panel should be installed into the rails at the same hole spacing (vertical height).

---

Figure 3  
**Attach rack mount extension arms**

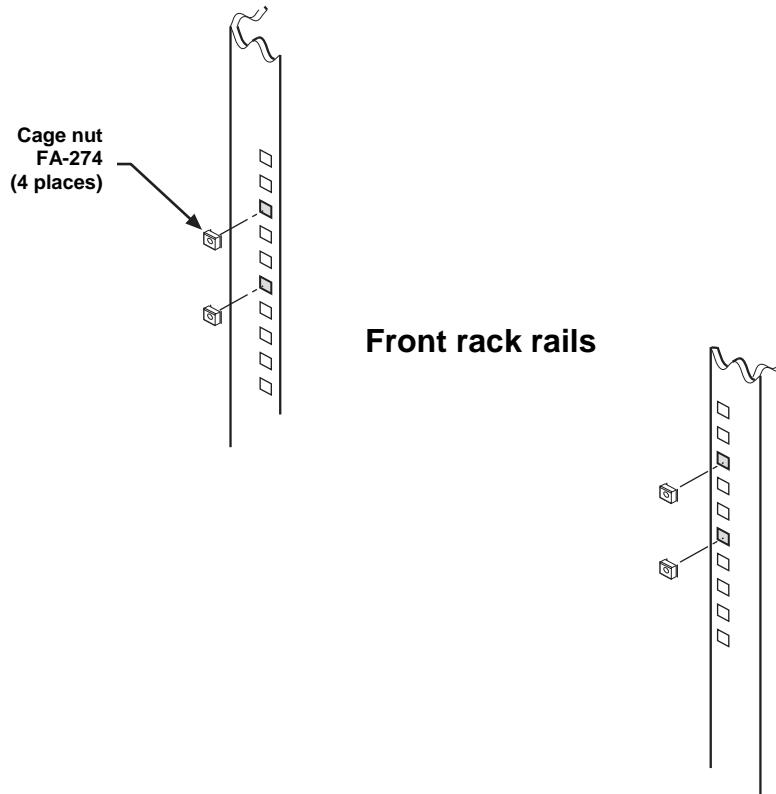

## Step 4: Install the instruments

**NOTE** Although the following step may be completed by one person, two people are recommended.

When rack-mounting restricts access to the main power cord, provide a separate main power disconnect device. This device must be located in close proximity to the equipment and within easy reach of the operator.

6. While still supporting the units, secure them to the front rack rails with four truss-head screws (#10-32x5/8PHTRSH).

Figure 4  
Instrument installation

