

Tektronix PPG1600, PPG3000, & PPG3200 PatternPro® Series Pattern Generator User Manual



077-1090-00

Tektronix

**Tektronix PPG1600, PPG3000, & PPG3200
PatternPro® Series Pattern Generator
User Manual**

Copyright © Tektronix. All rights reserved. Licensed software products are owned by Tektronix or its subsidiaries or suppliers, and are protected by national copyright laws and international treaty provisions.

Tektronix products are covered by U.S. and foreign patents, issued and pending. Information in this publication supersedes that in all previously published material. Specifications and price change privileges reserved.

TEKTRONIX and TEK are registered trademarks of Tektronix, Inc.

Contacting Tektronix

Tektronix, Inc.
14150 SW Karl Braun Drive
P.O. Box 500
Beaverton, OR 97077
USA

For product information, sales, service, and technical support:

- In North America, call 1-800-833-9200.
- Worldwide, visit www.tektronix.com to find contacts in your area.

Warranty

Tektronix warrants that this product will be free from defects in materials and workmanship for a period of one (1) year from the date of shipment. If any such product proves defective during this warranty period, Tektronix, at its option, either will repair the defective product without charge for parts and labor, or will provide a replacement in exchange for the defective product. Parts, modules and replacement products used by Tektronix for warranty work may be new or reconditioned to like new performance. All replaced parts, modules and products become the property of Tektronix.

In order to obtain service under this warranty, Customer must notify Tektronix of the defect before the expiration of the warranty period and make suitable arrangements for the performance of service. Customer shall be responsible for packaging and shipping the defective product to the service center designated by Tektronix, with shipping charges prepaid. Tektronix shall pay for the return of the product to Customer if the shipment is to a location within the country in which the Tektronix service center is located. Customer shall be responsible for paying all shipping charges, duties, taxes, and any other charges for products returned to any other locations.

This warranty shall not apply to any defect, failure or damage caused by improper use or improper or inadequate maintenance and care. Tektronix shall not be obligated to furnish service under this warranty a) to repair damage resulting from attempts by personnel other than Tektronix representatives to install, repair or service the product; b) to repair damage resulting from improper use or connection to incompatible equipment; c) to repair any damage or malfunction caused by the use of non-Tektronix supplies; or d) to service a product that has been modified or integrated with other products when the effect of such modification or integration increases the time or difficulty of servicing the product.

THIS WARRANTY IS GIVEN BY TEKTRONIX WITH RESPECT TO THE PRODUCT IN LIEU OF ANY OTHER WARRANTIES, EXPRESS OR IMPLIED. TEKTRONIX AND ITS VENDORS DISCLAIM ANY IMPLIED WARRANTIES OF MERCHANTABILITY OR FITNESS FOR A PARTICULAR PURPOSE. TEKTRONIX' RESPONSIBILITY TO REPAIR OR REPLACE DEFECTIVE PRODUCTS IS THE SOLE AND EXCLUSIVE REMEDY PROVIDED TO THE CUSTOMER FOR BREACH OF THIS WARRANTY. TEKTRONIX AND ITS VENDORS WILL NOT BE LIABLE FOR ANY INDIRECT, SPECIAL, INCIDENTAL, OR CONSEQUENTIAL DAMAGES IRRESPECTIVE OF WHETHER TEKTRONIX OR THE VENDOR HAS ADVANCE NOTICE OF THE POSSIBILITY OF SUCH DAMAGES.

[W2 – 15AUG04]

Table of Contents

Important safety information	v
General safety summary	v
Service safety summary	vii
Terms in this manual	vii
Symbols and terms on the product	viii
Preface	ix
Features	ix
Documentation	xi
Getting started	1
Installation	1
Controls and connectors	4
Functional verification	7
Instrument setup	7
Power on and verify instrument operation	8
Verify the eye diagram	9
Check other settings	10
Instructions specific to the PPG3200 series (Option FXD)	11
Input and output descriptions	13
Overview	13
Data outputs	14
Specifications	17
PPG3200 data outputs	17
PPG3000 & PPG1600 data outputs	18
Data patterns	19
Clock outputs	20
Jitter insertion	21
Trigger system	24
Clock inputs	24
Reference clock	25
Channel skew	25
Data error insertion	26
Control interfaces	26
Physical characteristics	26
Graphical user interface (GUI) touch screen	27
Remote programming	29
USB interface	29
Command information	29
Common commands	30
Summary	30

Reference	30
Regular commands	31
Summary	31
Reference	34
:DiGital[1 2 3 4]:PATtern:LENGth	34
:DiGital[1 2 3 4]:PATtern:TYPE	34
:DiGital[1 2 3 4]:PATtern:PLENGth	35
:DiGital[1 2 3 4]:PATtern:DATA	36
:DiGital[1 2 3 4]:PATtern:HDATa	37
:DiGital[1 2 3 4]:PATtern:SERRor	38
:DiGital[1 2 3 4]:PATtern:ERATe	38
:DiGital[1 2 3 4]:PATtern:ERATe:STATe	38
:DiGital[1 2 3 4]:PATtern:BSHift	39
:DiGital[1 2 3 4]:SIGNal[:POS :NEG]:CROSSover:[VALue]	39
:MMEMory:STORE:PDATa	40
:MMEMory:STORE:STATe	40
:MMEMory:LOAD:PDATa	40
:MMEMory:LOAD:STATe	41
:MMEMory:MOVE:PDATa	41
:MMEMory:MOVE:STATe	41
:MMEMory:DELeTe:PDATa	42
:MMEMory:DELeTe:STATe	42
:MMEMory:CATalog:PDATa?	42
:MMEMory:CATalog:STATe?	43
:OUTPut0:SOURce	43
:OUTPut0:DIVider	43
:OUTPut[1 2 3 4]:POLarity	44
:OUTPut[1 2 3 4][:STATe]	44
:OUTPut:CLOCK:DIVider	44
:SENSe:ROSCillator:SOURce	45
[:SOURce]:FREQUency[:CW :FIXed]	45
[:SOURce]:SKEW[1 2 3 4]	45
[:SOURce]:PM[1 2 3 4][:HF][:STATe]	46
[:SOURce]:PM[1 2 3 4][:HF]:INTernal1[:DEViation]	46
[:SOURce]:PM[1 2 3 4][:HF]:INTernal1:FREQUency	46
[:SOURce]:PM[1 2 3 4][:HF]:INTernal1:STATe	47
[:SOURce]:PM[1 2 3 4][:HF]:INTernal2[:DEViation]	47
[:SOURce]:PM[1 2 3 4][:HF]:INTernal2:STATe	47
[:SOURce]:PM[1 2 3 4][:HF]:INTernal4:CALibration	48
[:SOURce]:PM[1 2 3 4][:HF]:INTernal4[:DEViation]	48
[:SOURce]:PM[1 2 3 4][:HF]:INTernal4:FILTer	48

[[:SOURce]:PM[1 2 3 4][[:HF]:INTernal4:FREQuency].....	49
[[:SOURce]:PM[1 2 3 4][[:HF]:INTernal4:PLENgtH].....	49
[[:SOURce]:PM[1 2 3 4][[:HF]:INTernal4:STATe].....	49
[[:SOURce]:PM:LF[:INTernal3][[:DEViation]].....	50
[[:SOURce]:PM:LF[:INTernal3]:FREQuency].....	50
[[:SOURce]:PM:LF[:INTernal3]:STATe].....	50
[[:SOURce]:VOLTage[1 2 3 4][[:POS]:NEG][[:LEVel][[:IMMediate]:[:AMPLitude].].....	51
[[:SOURce]:VOLTage[1 2 3 4][[:POS]:NEG][[:LEVel][[:IMMediate]:OFFSet].....	51
[[:SOURce]:VOLTage[1 2 3 4][[:POS]:NEG][[:LEVel][[:IMMediate]:TERMination].....	51
[[:SOURce]:VOLTage[1 2 3 4][[:LEVel][[:IMMediate]:LINK].....	52
:SYSTem:ERRor[:NEXT]?.....	52
:TRIGger:SOURce.....	53
:TRIGger:LOCK.....	53
User service.....	55
Service offerings.....	55
General care.....	55
Preventive maintenance.....	56
Fuse replacement.....	57
Repack the instrument for shipment.....	57
Compliance information.....	59
EMC compliance.....	59
Safety compliance.....	60
Environmental considerations.....	62
Index.....	

List of Figures

Figure 1: Front panel controls and connectors	4
Figure 2: Rear panel connectors	5
Figure 3: Verification setup.....	7
Figure 4: Clock (top) and data (bottom) waveforms	9
Figure 5: Eye diagram for the PPG3200 series (Option FXD).....	10
Figure 6: Block diagram.....	14
Figure 7: Available output range (PPG1600, PPG3000, and PPG3200 with ADJ option).....	15
Figure 8: Jitter insertion block diagram.....	21
Figure 9: Low frequency (Option LFJIT) and high frequency (Option HFJIT) jitter insertion rates, based on a data rate of 28 Gb/s	22
Figure 10: GUI Main menu	27

List of Tables

Table i: Product description	x
Table ii: Product options.....	xi
Table 1: Power requirements.....	2
Table 2: Maximum operating environmental considerations	3
Table 3: Front panel controls and connectors	4
Table 4: Rear panel connectors	5
Table 5: SJ modulation range curve points	23
Table 6: GUI menu parameter locations	27
Table 7: Models and Model codes.....	30

Important safety information

This manual contains information and warnings that must be followed by the user for safe operation and to keep the product in a safe condition.

To safely perform service on this product, additional information is provided at the end of this section. (See page vii, *Service safety summary*.)

General safety summary

Use the product only as specified. Review the following safety precautions to avoid injury and prevent damage to this product or any products connected to it. Carefully read all instructions. Retain these instructions for future reference.

Comply with local and national safety codes.

For correct and safe operation of the product, it is essential that you follow generally accepted safety procedures in addition to the safety precautions specified in this manual.

The product is designed to be used by trained personnel only.

Only qualified personnel who are aware of the hazards involved should remove the cover for repair, maintenance, or adjustment.

Before use, always check the product with a known source to be sure it is operating correctly.

This product is not intended for detection of hazardous voltages.

Use personal protective equipment to prevent shock and arc blast injury where hazardous live conductors are exposed.

When incorporating this equipment into a system, the safety of that system is the responsibility of the assembler of the system.

To avoid fire or personal injury

Use proper power cord. Use only the power cord specified for this product and certified for the country of use.

Do not use the provided power cord for other products.

Ground the product. This product is grounded through the grounding conductor of the power cord. To avoid electric shock, the grounding conductor must be connected to earth ground. Before making connections to the input or output terminals of the product, make sure that the product is properly grounded.

Do not disable the power cord grounding connection.

Power disconnect. The power cord disconnects the product from the power source. See instructions for the location. Do not position the equipment so that it is difficult to operate the power cord; it must remain accessible to the user at all times to allow for quick disconnection if needed.

Observe all terminal ratings. To avoid fire or shock hazard, observe all ratings and markings on the product. Consult the product manual for further ratings information before making connections to the product.

Do not apply a potential to any terminal, including the common terminal, that exceeds the maximum rating of that terminal.

The measuring terminals on this product are not rated for connection to mains or Category II, III, or IV circuits.

Do not operate without covers. Do not operate this product with covers or panels removed, or with the case open. Hazardous voltage exposure is possible.

Avoid exposed circuitry. Do not touch exposed connections and components when power is present.

Do not operate with suspected failures. If you suspect that there is damage to this product, have it inspected by qualified service personnel.

Disable the product if it is damaged. Do not use the product if it is damaged or operates incorrectly. If in doubt about safety of the product, turn it off and disconnect the power cord. Clearly mark the product to prevent its further operation.

Examine the exterior of the product before you use it. Look for cracks or missing pieces.

Use only specified replacement parts.

Use proper fuse. Use only the fuse type and rating specified for this product.

Wear eye protection. Wear eye protection if exposure to high-intensity rays or laser radiation exists.

Do not operate in wet/damp conditions. Be aware that condensation may occur if a unit is moved from a cold to a warm environment.

Do not operate in an explosive atmosphere.

Keep product surfaces clean and dry. Remove the input signals before you clean the product.

Provide proper ventilation. Refer to the installation instructions in the manual for details on installing the product so it has proper ventilation.

Slots and openings are provided for ventilation and should never be covered or otherwise obstructed. Do not push objects into any of the openings.

Provide a safe working environment. Always place the product in a location convenient for viewing the display and indicators.

Avoid improper or prolonged use of keyboards, pointers, and button pads. Improper or prolonged keyboard or pointer use may result in serious injury.

Be sure your work area meets applicable ergonomic standards. Consult with an ergonomics professional to avoid stress injuries.

Use care when lifting and carrying the product. This product is provided with handles for lifting and carrying.

Service safety summary

The *Service safety summary* section contains additional information required to safely perform service on the product. Only qualified personnel should perform service procedures. Read this *Service safety summary* and the *General safety summary* before performing any service procedures.

To avoid electric shock. Do not touch exposed connections.

Do not service alone. Do not perform internal service or adjustments of this product unless another person capable of rendering first aid and resuscitation is present.

Disconnect power. To avoid electric shock, switch off the product power and disconnect the power cord from the mains power before removing any covers or panels, or opening the case for servicing.

Use care when servicing with power on. Dangerous voltages or currents may exist in this product. Disconnect power, remove battery (if applicable), and disconnect test leads before removing protective panels, soldering, or replacing components.

Verify safety after repair. Always recheck ground continuity and mains dielectric strength after performing a repair.

Terms in this manual

These terms may appear in this manual:



WARNING. *Warning statements identify conditions or practices that could result in injury or loss of life.*



CAUTION. *Caution statements identify conditions or practices that could result in damage to this product or other property.*

Symbols and terms on the product

These terms may appear on the product:

- DANGER indicates an injury hazard immediately accessible as you read the marking.
- WARNING indicates an injury hazard not immediately accessible as you read the marking.
- CAUTION indicates a hazard to property including the product.



When this symbol is marked on the product, be sure to consult the manual to find out the nature of the potential hazards and any actions which have to be taken to avoid them. (This symbol may also be used to refer the user to ratings in the manual.)

The following symbol(s) may appear on the product:



CAUTION
Refer to Manual



Protective Ground
(Earth) Terminal

Preface

The Tektronix PatternPro line of high-performance pattern generators offer single and multi-channel configurations capable of data rates up to 32 Gb/s. With optional jitter insertion, the PPG line offers a flexible, cost effective and easy to use test solution supporting high speed applications such as 100 Gigabit Ethernet, 32G Fibre channel, PAM4, DP-QPSK testing, and a broad range of receiver test applications. The single unit multi-channel configurations provide aligned, pattern-independent data outputs that support testing of crosstalk immunity and multi-channel functionality. The PPG line can be paired with the Tektronix PED line of Error Detector products to provide a complete BER test capability.

The data rate can be programmed over a broad range of values. The output may be either built-in PRBS patterns or programmed user data patterns.

Features

The PPG pattern generators series provide the following features:

- 1.5 Gb/s to 16 Gb/s operation (PPG1600 series)
- 1.5 Gb/s to 30 Gb/s operation (PPG3000 series)
- 1.5 Gb/s to 32 Gb/s operation (PPG3200 series)
- Fully integrated benchtop instruments
- Available with 1, 2, or 4 output channels
 - Independent data on channels
 - Independent channel skew adjustment
 - Independent channel pattern bit shift
- Adjustable data amplitude and offset (PPG1600 and PPG3000 series)
 - 250 mV to 2 V single ended (500 mV to 4 V differential)
 - -2 V to 3 V window
- Fast rise/fall time (PPG3200 series)
 - 12ps 10/90% rise/fall time (Option FXD)
 - -500 mV to 0 V fixed amplitude data output (Option FXD)
 - 300 mV to 1 V single ended adjustable; 600 mV to 2 V differential (Option ADJ)
- User programmable data or built-in PRBS patterns

- Adjustable internal clock source
 - Full rate
 - 10 kb/s resolution
 - Selectable prescaler output
- External clock input
- Trigger output
 - programmable as pattern trigger or clock/n
- Jitter insertion (option):
 - High Frequency SJ/RJ/BUJ jitter insertion (Option HFJIT)
 - Low frequency jitter insertion (Option LFJIT)
 - External modulation input
- Save up to twenty-five user patterns in nonvolatile memory
- Save up to twenty-five generator setups in nonvolatile memory
- Touch screen graphical user interface & USB TMC interfaces
- 3RU height, full-rack design for 1-channel or 2-channel unit
- 6RU height, full rack design for 4-channel unit

Table i: Product description

Instrument	Maximum data rate	Differential channels
PPG1601	16 Gb/s	1
PPG1602	16 Gb/s	2
PPG1604	16 Gb/s	4
PPG3001	30 Gb/s	1
PPG3002	30 Gb/s	2
PPG3004	30 Gb/s	4
PPG3201	32 Gb/s	1
PPG3202	32 Gb/s	2
PPG3204	32 Gb/s	4

Table ii: Product options

Option	Description
HFJIT	High frequency jitter insertion (SJ/RJ/BUJ) ¹
LFJIT	Low frequency jitter option (PPG3200 series only) ²
FXD	Fixed amplitude output (PPG3200 series only) ¹
ADJ	Variable amplitude output (PPG3200 series only) ¹

¹ These options must be the same on all channels (Option HFJIT must be on all channels or none, and the data output option must be the same for all channels). One unit of each of these options is needed for each output channel of the instrument.

² Option LFJIT is part of the clock source and one unit of this option is needed for the instrument, regardless of the number of output channels.

Documentation

The following documentation is available:

- PPG/PED Safety & Installation Manual, printed version shipped with the product
- This PPG1600, PPG3000, & PPG3200 Series PatternPro Pattern Generator User Manual (PDF versions only, downloadable from the Tektronix Web Site)
- Product datasheets (PDF versions only, downloadable from the Tektronix Web Site)
- Declassification & Security instructions (PDF versions only, downloadable from the Tektronix Web Site)

Check the Tektronix Web Site for additional product documentation at www.Tektronix.com.

Getting started

Installation

The instrument was carefully inspected electrically and mechanically before shipment. After unpacking all items from the shipping carton, check for any obvious signs of physical damage that may have occurred during transit (there might be a protective film over the display, which can be removed). Report damage to the shipping agent immediately. Save the original packing carton for possible future shipment.

Accessories The following accessories are included with your instrument:

- Pattern generator
- Power cord
- Rack mount ears on the front of the instrument
- PPG/PED Installation & Safety instructions
- Accessories as ordered

Power requirements



CAUTION. *Operating the instrument on an incorrect line voltage can cause damage, possibly voiding the warranty. To avoid this, operate the instrument with the correct line voltage.*

The instrument operates from a single-phase line voltage listed in the following table. Line voltage and line frequency are automatically sensed; there are no switches to set. Check to ensure the operating voltage in your area is compatible.

Table 1: Power requirements

Item	Description
Voltage	100 V to 240 V
Frequency	50 Hz to 60 Hz
Power	
PPG1601, PPG1602, PPG3001, PPG3002, PPG3201, PPG3202	360 W, maximum
PPG1604, PPG3004, PPG3204	720 W, maximum
Power fuse	
PPG1601, PPG1602, PPG3001, PPG3002, PPG3201, PPG3202	T 2A 250V
PPG1604, PPG3004, PPG3204	T 4A 250V

The power cord supplied with the instrument contains a separate ground for use with grounded outlets. When proper connections are made, the instrument chassis is connected to power line ground through the ground wire in the power cord providing protection against electric shock.

Ventilation

The unit has four fans in the rear, as well as cooling vents on the bottom and side panels to keep it from overheating.



CAUTION. *Inadequate ventilation can damage the instrument; to avoid damaging the instrument, observe the following precautions:*

Do not block the cooling vents.

Do not position any devices adjacent to the instrument that force air (heated or unheated) into or onto the instrument surfaces or cooling vents. This additional airflow could compromise performance.

When rack mounting the instrument, ensure there is adequate airflow around the instrument rear, sides, and bottom to ensure proper cooling. Adequate airflow enables air temperatures within approximately one inch of the instrument surfaces to remain within specified limits under all operating conditions.

Environmental considerations

The following table describes the maximum operating environmental ratings for your instrument.

Table 2: Maximum operating environmental considerations

Feature	Description
Temperature	40 °C (104 °F)
Humidity	80% for temperatures up to 31 °C (88 °F) decreasing linearly to 50% at 40 °C (104 °F)
Altitude	2000 m (6562 ft.)

Controls and connectors

The following illustration and table describe the front panel controls and connectors. The illustration shows a 4-channel instrument; 1-channel and 2-channel instruments have fewer controls in different locations on the instrument.

NOTE. *The exact location and spacing of the Data Out connectors may be different depending on the instrument type or output options ordered with the instrument.*

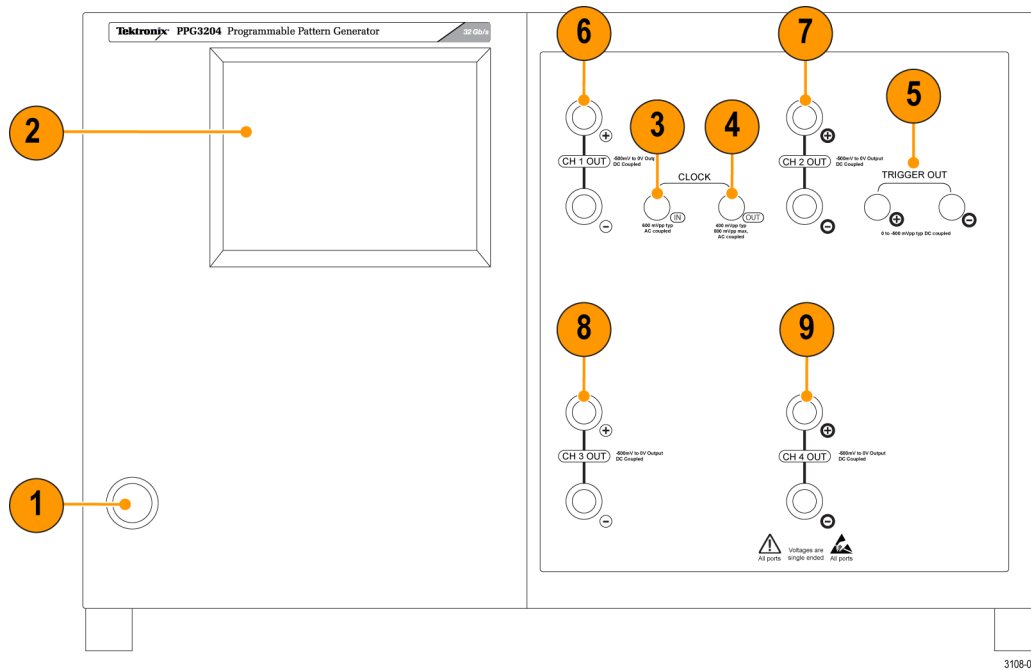

Figure 1: Front panel controls and connectors

Table 3: Front panel controls and connectors

Item	Description
1 On/off switch	Push this button to turn the instrument on and off. The green indicator inside the button lights up when the instrument is on.
2 Display	The display is a touch screen graphical user interface.
3 Clock In	Clock input with 2.92 mm connectors (PPG1600 and PPG3000 series) or 2.4 mm connectors (PPG3200 series), AC coupled. Used to supply an external clock signal.
4 Clock Out	Clock output with 2.92 mm connectors (PPG1600 and PPG3000 series) or 2.4 mm connectors (PPG3200 series), AC coupled
5 Trigger Out	SMA Differential Trigger Output. Levels swing from -500 mV to 0 V. Can be used single ended.
6 Data Out connectors (Ch1)	Plus and minus Data outputs with 2.92 mm connectors (PPG1600 and PPG3000 series) or 2.4 mm connectors (PPG3200 series)

Table 3: Front panel controls and connectors (cont.)

Item	Description
7 Data Out connectors (Ch2)	Plus and minus Data outputs with 2.92 mm connectors (PPG1602, PPG1604, PPG3002 or PPG3004) or 2.4 mm connectors (PPG3202 or PPG3204)
8 Data Out connectors (Ch3)	Plus and minus Data outputs with 2.92 mm connectors (PPG1604, PPG3004) or 2.4 mm connectors (PPG3204)
9 Data Out connectors (Ch4)	Plus and minus Data outputs with 2.92 mm connectors (PPG1604, PPG3004) or 2.4 mm connectors (PPG3204)

The following illustration and table describe the rear panel connectors. The illustration shows a 4-channel instrument; 1-channel and 2-channel instruments have fewer controls in different locations on the instrument.

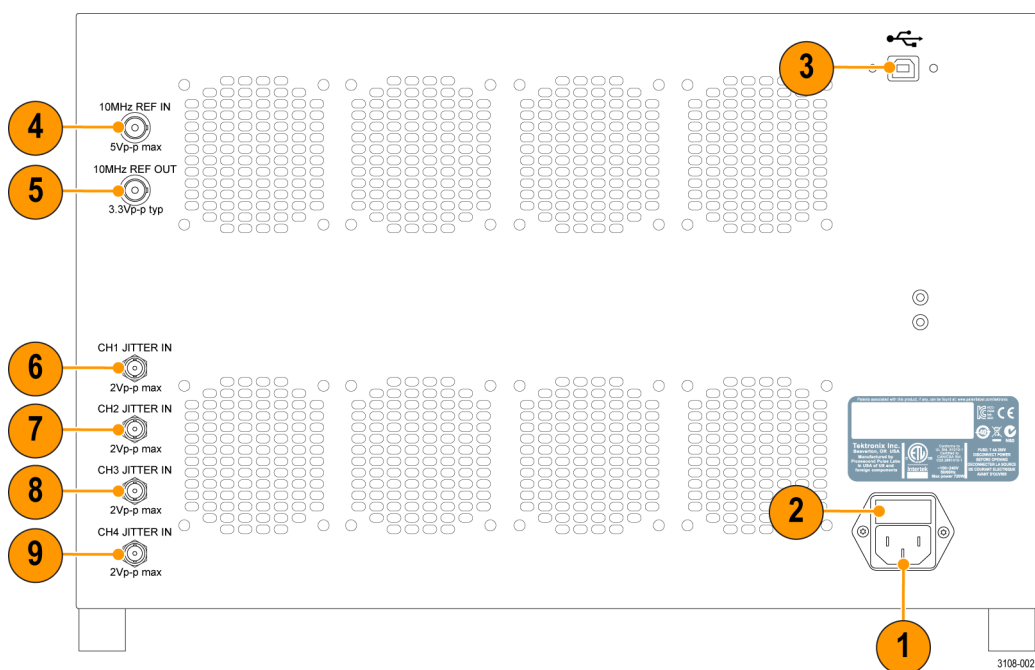

Figure 2: Rear panel connectors

Table 4: Rear panel connectors

Item	Description
1 AC line receptacle	Connect the appropriate power cord here.
2 Fuse holder	Line fuse, 5 X 20 mm
3 USB connection	Connect the USB cable here to control the instrument from an external computer.
4 10 MHz REF IN	BNC input for external frequency reference
5 10 MHz REF OUT	BNC output for buffered version of the frequency reference (internal or external)
6 JITTER IN (Ch1)	SMA Ch1 input for external jitter insertion (Option JIT)
7 JITTER IN (Ch2)	SMA Ch2 input for external jitter insertion (Option JIT)

Table 4: Rear panel connectors (cont.)

Item	Description
8 JITTER IN (Ch3)	SMA Ch3 input for external jitter insertion (Option JIT)
9 JITTER IN (Ch4)	SMA Ch4 input for external jitter insertion (Option JIT)

Functional verification

Instrument setup

A typical setup for verifying the pattern generator operation is shown in the following figure. The diagram uses only the + side of all differential connections, the - side can be tested in the same manner. Use a Tektronix DSA8300 Digital Serial Analyzer Sampling Oscilloscope or similar for functional verification.

CAUTION. *Damage to the pattern generator and/or associated equipment can occur if the input and output voltage ratings are exceeded. Check the input and output voltage ratings for your equipment. The following illustration shows electrical attenuators where voltage ratings are commonly exceeded.*

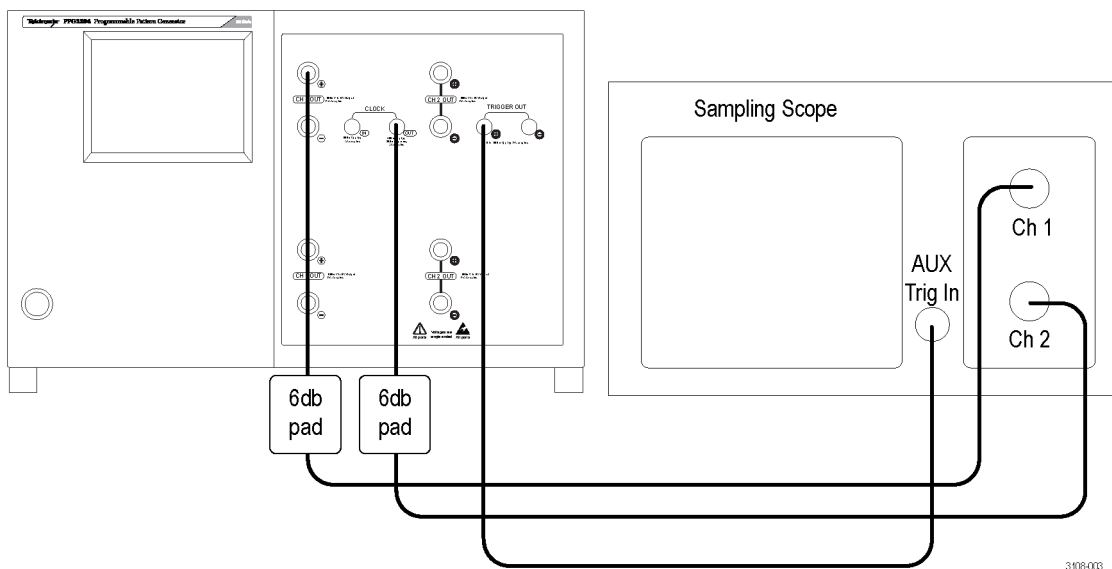

Figure 3: Verification setup

Power on and verify instrument operation

The following steps assume the unit is connected as shown in the verification setup.

NOTE. *Note: The generator is internally temperature compensated for timing and output level continuously and automatically. Internal timing calibration will also take place whenever the frequency is set (either manually or through remote programming). Setting the frequency (or resetting the frequency to its current value) is recommended after an initial 15-minute warm-up, or if a significant change in ambient temperature has occurred during operation.*

1. Push front panel on/off switch.
 - The green light on the switch turns on.
 - The instrument goes through the start-up sequence.
 - The Main menu displays on the touch screen.
2. Select **UTILITY** by touching the on-screen button.
3. Select **SAVE**.
4. Select **RECALL DEFAULTS** (The instrument loads all the default settings.)
5. Select **BACK**.
6. Select **MAIN**.
7. Turn **OUTPUT ON**.
8. Use the **AUTO SCALE** function on the sampling oscilloscope to identify and display signals.
9. Adjust the sampling oscilloscope voltage, timing and display settings as needed.
 - Channel 1 shows PRBS data with pattern trigger.
 - Channel 2 shows a square wave at the default clock rate.
 - The output should be similar to the following figure (the displayed data pattern may differ).

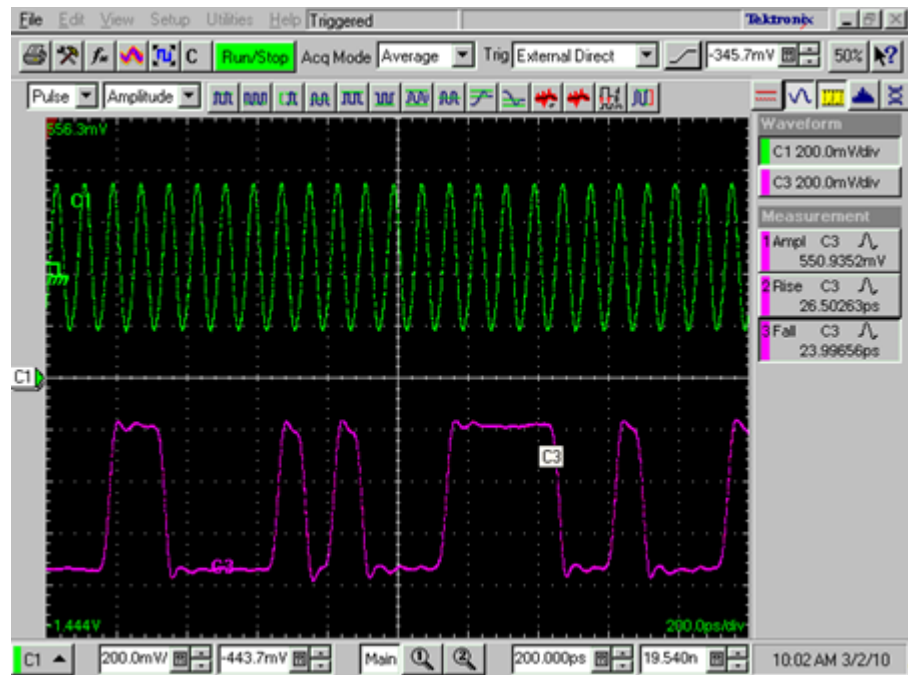

Figure 4: Clock (top) and data (bottom) waveforms

Verify the eye diagram

1. Select **UTILITY**.
2. Select **TRIGGER**.
3. Select **TRIGGER TYPE = CLK/N**.
4. Set **N DIVISOR** to **64**.
5. Turn off the display on the oscilloscope channel 1 (clock signal).

6. Adjust the sampling oscilloscope amplitude, timing and display as needed. Output should be similar to the following figure.

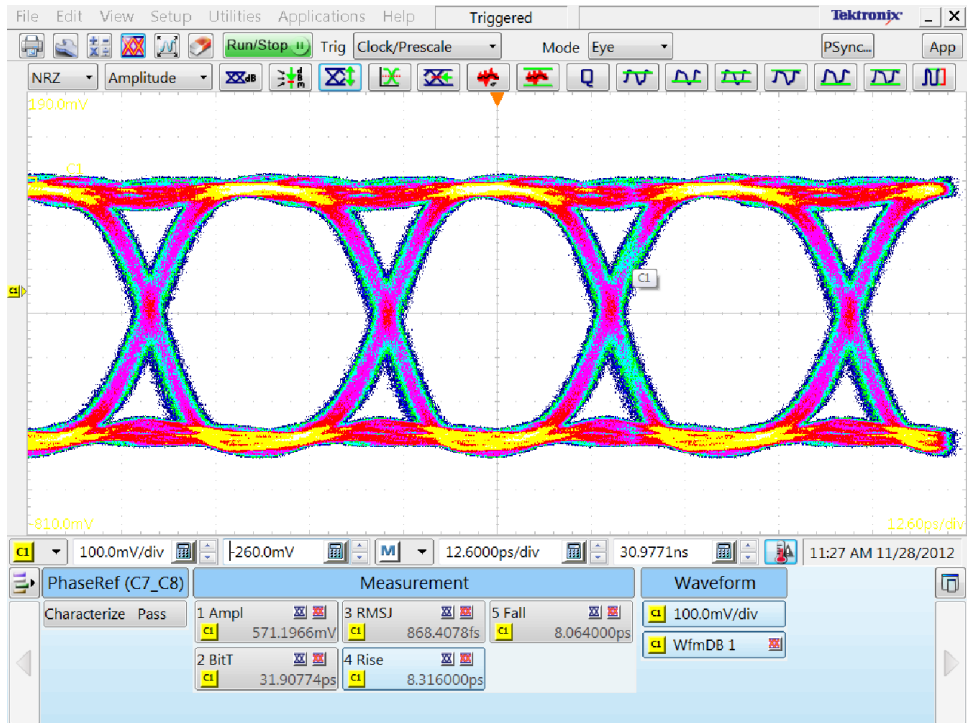

Figure 5: Eye diagram for the PPG3200 series (Option FXD)

Check other settings

Access the remaining menus to experiment with other settings.

Instructions specific to the PPG3200 series (Option FXD)

- Each side of the differential signal has a typical voltage swing of from 0 V to -500 mV.
- Treat the outputs with care as they are static sensitive.
- For DC-coupled use:
 - Terminate the DUT or load with 50 Ω to ground.
 - Terminate any unused output 50 Ω to ground.
- For AC-coupled use:
 - Provide a 50 Ω to ground path prior to any DC block (a bias tee with 50 Ω to ground, for example use a bias tee, model number PSPL5542, available from Tektronix).
 - Terminate any unused output 50 Ω to ground.

Input and output descriptions

Overview

RF connectors Data and Clock front panel RF connectors are 2.92 mm (K type) for the PPG1600 and PPG3000 series. Data and clock connectors are 2.4 mm for the PPG3200 series. All other front panel RF connections are SMA.

Connector torque specifications

Minimum:	2 in-lbs (0.226 N-m)
Recommended:	7-10 in-lbs (0.791-1.130 N-m)
Maximum:	15 in-lb (1.695 N-m)

NOTE. Please note the special termination instructions for the PPG3200 instruments with Option FXD. (See page 11, Instructions specific to the PPG3200 series (Option FXD).)

Data out and /Data out These are the primary outputs from the unit. The outputs can be used single-ended or differentially. Data pattern, levels and timing can be controlled manually or remotely.

Trig out and /Trig out These differential outputs provide a timing reference for viewing the data signals. The output amplitudes are fixed. Trigger options are PATTERN or CLOCK/N.

When using a pattern trigger, the trigger corresponds to the beginning of a pattern. The pattern trigger mode can be used with user-defined or PRBS data. For the CLOCK/N trigger mode, the clock frequency is reduced by a factor of N where the value N is required to be a multiple of 64.

Clk out The clock output reflects the data rate; there is one full clock cycle per bit of data. The clock output is AC coupled and the amplitude is fixed. The internal clock actually operates over a range of 15 GHz to 30 GHz (PPG3000 series) or 16 GHz to 32 GHz (PPG1600 and PPG3200 series). When data rates <15 Gb/s (PPG1600 and PPG3000 series) or <16 GHz (PPG3200 series) are used, the internal clock will operate at a multiple of the data rate and bit-stretching is used to produce data at the specified rate. A built-in clock divider can be used to divide the internal clock before it is sent to the clock output (divisors of 1, 2, 4, 8, 16).

Clk in This is the input used to supply an external clock. Clock frequency is restricted to a range of 15 GHz to 30 GHz (PPG3000 series) or 16 GHz to 32 GHz (PPG3200 series)—same as the range of the internal clock source.

NOTE. *The external clock input is not available for the PPG1600 series.*

Functional block diagram

The basic functional blocks are shown in the following figure.

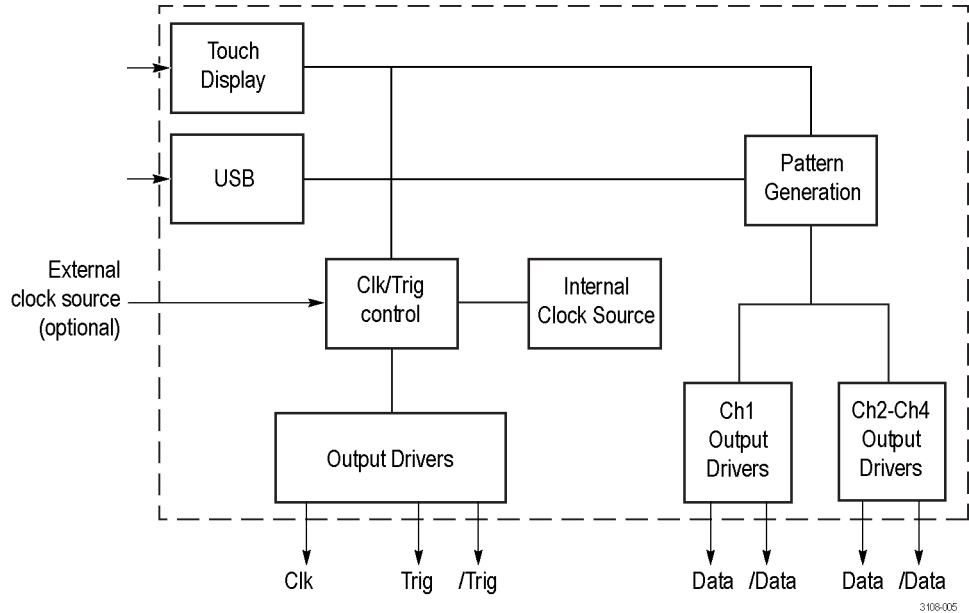

Figure 6: Block diagram

Data outputs

Output range The instrument is designed to drive a 50 Ω load. The voltage window for the PPG3000 series is adjustable over the range from -2 V to +3 V. The voltage window for the PPG3200 series with Option FXD is fixed over a range from 0 V to -500 mV. The voltage window for the PPG1600 series, PPG3200 series, and PPG3200 series with Option ADJ is adjustable over a range of -2 V to +3 V.



WARNING. *To ensure proper operation, never load the output with less than 50 Ω.*

**Termination voltage
(PPG1600, PPG3000, and
PPG3200 with ADJ option)**

This setting is used in cases where the load being driven is terminated at a level other than zero volts. The effect of termination voltage on the output voltage is shown in the following figure.



WARNING. To ensure proper operation, never load the output with a termination voltage less than V_{oh} minus 3 V.

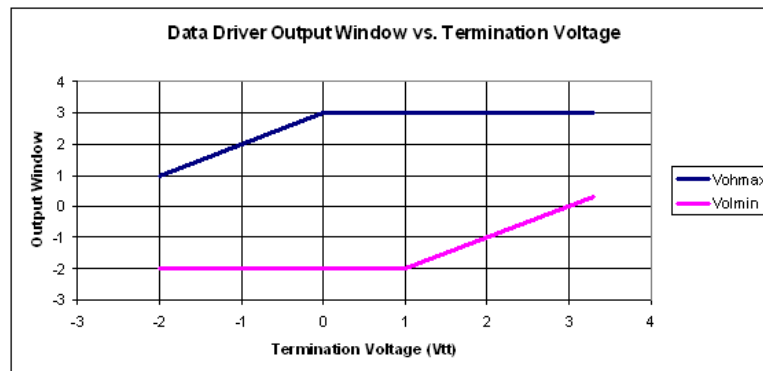

Figure 7: Available output range (PPG1600, PPG3000, and PPG3200 with ADJ option)

Specifications

All specifications apply to all models unless noted otherwise.

PPG3200 data outputs

There is a true and a complement output for each channel. Specifications apply to each output individually.

Option FXD Amplitude DC coupled. Each side of the differential pair swings from -500 mV to 0 V. Ground-referenced CML. Terminated 50 Ω to ground.

Single-ended. 500 mV, typical

Differential. 1.0 V, typical

Option FXD Rise/fall time Oscilloscope bandwidth can impact the measured signal rise time.

20 to 80%. 8 ps, typical

10 to 90%. 12 ps, typical

Option ADJ Amplitude Each positive and negative differential output is independently programmable.

Single-ended. 300 mV to 1.0 V

Differential. 600 mV to 2.0 V

Option ADJ Offset window -2 V to +3 V, programmable/adjustable

Option ADJ Rise/fall time Oscilloscope bandwidth can impact the measured signal rise time.

20 to 80%. 11 ps, typical

10 to 90%. 16 ps, typical

Option ADJ Termination voltage range -2.0 V to +3.3 V window. Programmable/adjustable. Applied by user via 50 Ω .

Data output jitter	250 fs _{RMS} RJ typical at 32 Gb/s using PRBS 2 ¹¹ -1 pattern
Connector type	2.4 mm
Output impedance	50 Ω. Single-ended 100 Ω. Differential

PPG3000 & PPG1600 data outputs

Amplitude range	250 mV to 2.0 V. Single-ended 500 mV to 4.0 V. Differential. Each positive and negative differential output is independently programmable.
Offset range	-2 V to +3.0 V window. Programmable/adjustable.
Termination voltage range	-2.0 V to +3.3 V window. Programmable/adjustable. Applied by user via 50 Ω.
Crossing point	Programmable/adjustable Range. 35% to 65%, typical. Tested using 50% mark density pattern. Resolution. 1%
Rise/fall time	Oscilloscope bandwidth can impact the measured signal rise time. 20% - 80%. 17 ps, typical 10% - 90%. 25 ps, typical
Data output jitter	350 fs _{RMS} , RJ typical at 28 Gb/s using PRBS 2 ¹¹ -1 pattern
Connector type	2.92 mm
Output impedance	50 Ω. Single-ended 100 Ω. Differential

Data patterns

Pattern type	Data (from memory) or PRBS. Length and type are individually settable on multi-channel generators.
Data rate	<p>Programmable/adjustable</p> <p>Range. 1.5 Gb/s to 16 Gb/s, (PPG1600 series) 1.5 Gb/s to 30 Gb/s, (PPG3000 series) 1.5 Gb/s to 32 Gb/s (PPG3200 series)</p> <p>Resolution. 10 kb/s</p> <p>Accuracy. ± 5 ppm</p>
PRBS pattern lengths	<p>Independently selected on multi-channel units</p> <p>2⁷ -1 bits. Polynomial = $X^7 + X^6 + 1$</p> <p>2⁹ -1 bits. Polynomial = $X^9 + X^5 + 1$</p> <p>2¹¹ -1 bits. Polynomial = $X^{11} + X^9 + 1$</p> <p>2¹⁵ -1 bits. Polynomial = $X^{15} + X^{14} + 1$</p> <p>2²³ -1 bits. Polynomial = $X^{23} + X^{18} + 1$</p> <p>2³¹ -1 bits. Polynomial = $X^{31} + X^{28} + 1$</p>
Data pattern depth	<p>Range. 2 to 4,194,304 bits. For 1 channel generator (4 Mbits). 2 to 2,097,152 bits. For 2 or 4 channel generators (2 Mbits/channel).</p> <p>Resolution. 1 bit</p>

Clock outputs

The clock outputs are single-ended, applicable for internal clock. The internal clock rate ranges from 15 GHz to 30 GHz (PPG3000 series) and 16 GHz to 32 GHz (PPG1600 and PPG3200 series).

PPG1600 Clock output frequency. (Internal clock)/(n), n = 2,4,8, or 16 user programmable

PPG3000 Clock output frequency. (Internal clock)/(n), n = 1,2,4,8, or 16 user programmable

PPG3200 Divided Clock output frequency. (Internal clock)/(n), n = 2,4,8, or 16 user programmable

PPG3200 Full Rate Clock output frequency (single output for PPG3201/2, quad output for PPG3204). Internal clock

Amplitude	Amplitude varies with frequency 600 mV _{p-p} , typical; 200 mV _{p-p} minimum; 1.0 V _{p-p} maximum
Output impedance	50 Ω, AC-coupled
Maximum external DC voltage	±5 V
Jitter	< 200 fs _{RMS} typical, measured by spectrum analyzer on 1010 pattern, phase noise integrated from 1 kHz to 1 GHz.
Connector type	2.92 mm (PPG3000 & PPG1600) 2.4 mm (PPG3200)

Jitter insertion

The pattern generator can be ordered with built-in jitter options. The PPG3200 series are available with Option LFJIT and Option HFJIT; the PPG1600 and PPG3000 series are available with Option HFJIT only. The jitter insertion is the delay modulation of the data channels. Option HFJIT applies to each channel individually; Option LFJIT applies equally to clock and data.

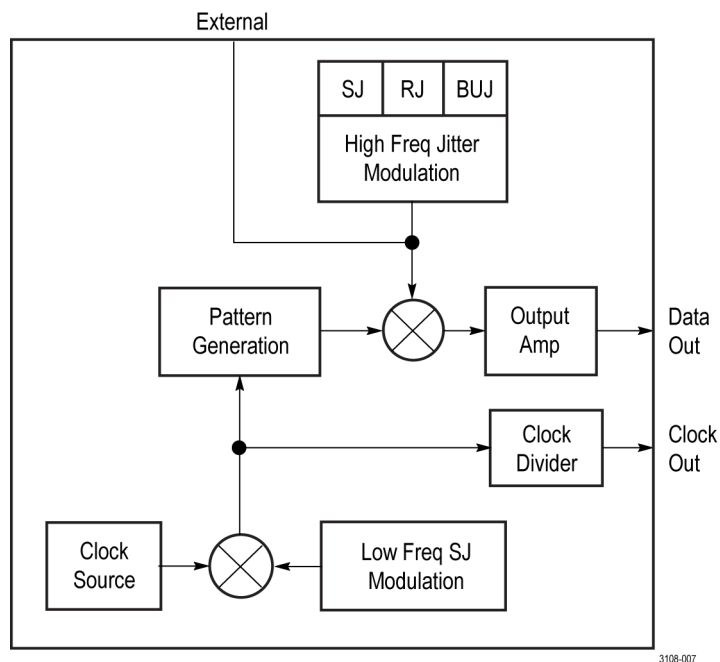

Figure 8: Jitter insertion block diagram

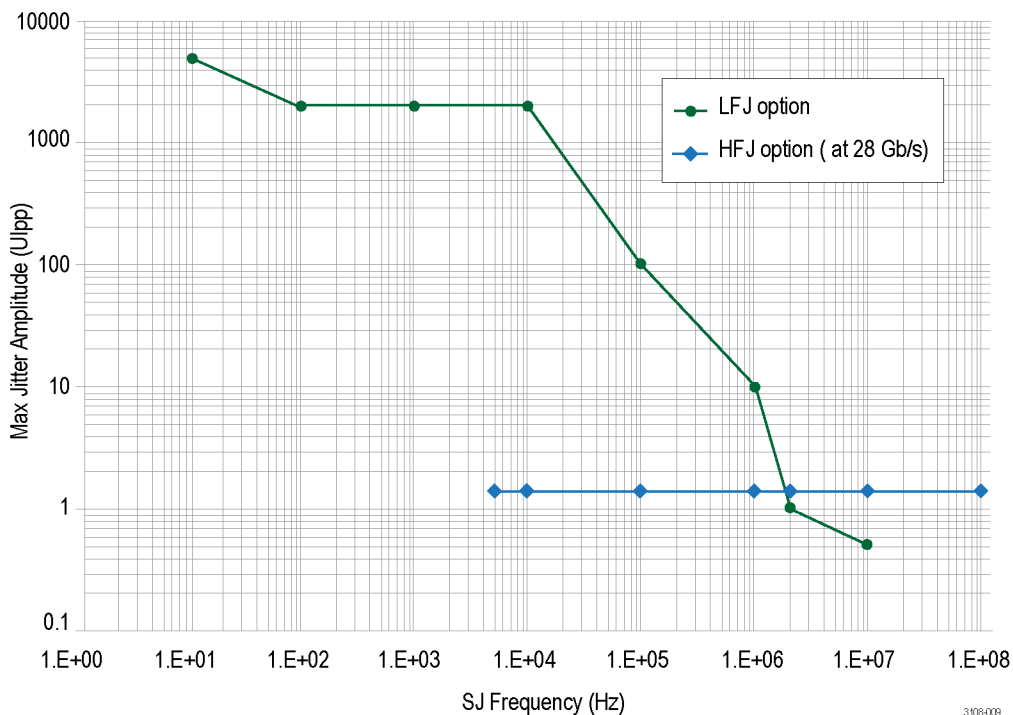

Figure 9: Low frequency (Option LFJIT) and high frequency (Option HFJIT) jitter insertion rates, based on a data rate of 28 Gb/s

High frequency jitter insertion option (Option HFJIT)

Add-on option for the instrument. Independent jitter sources on each channel. Sum of external, internal sine, and internal noise. Total range depends on modulation frequencies. Exceeding the range can generate errors.

Total modulation range. 50 ps_{p-p}

Built-in sine source

Programmable from either the front panel touch screen or remote control.

Frequency range. 5 kHz to 100 MHz

Amplitude range. 0 to 50 ps_{p-p}

Accuracy. ±10%, typical

Built-in random noise source

Programmable from either the front panel touch screen or remote control.

Amplitude range. 0 to 5 ps_{RMS}

Accuracy. ±10% typical

Built-in BUJ source	Programmable from either the front panel touch screen or remote control.
	Amplitude range. 0 to 50 ps _{p-p}
	Modulation data rates. 100 Mb/s to 2.5 Gb/s
	PRBS sequences. 7,9,11,15,23,31
	Filter values. 25/50/100 MHz filters
External modulation input	DC coupled, 3 dB bandwidths
	Frequency range. DC to 100 MHz
	Amplitude range. 0 to 50 ps _{p-p}
	Maximum input. 1 V _{p-p}
Low frequency jitter insertion (Option LFJIT)	Add-on option.
	The specifications below apply when the data rate equals the internal clock rate frequency of 16 to 32 GHz. For each frequency octave below, the internal clock rate, the specifications below will be reduced by half. Thus when the data rate is 8 to 16 Gb/s, the values below will be divided by 2. When the data rate is 4 to 8 Gb/s, the values will be divided by 4.

Table 5: SJ modulation range curve points

Parameter	Value
10 Hz f_{mod}	5000 UI _{p-p}
100 Hz f_{mod}	2000 UI _{p-p}
1 kHz f_{mod}	2000 UI _{p-p}
10 kHz f_{mod}	2000 UI _{p-p}
100 kHz f_{mod}	100 UI _{p-p}
1 MHz f_{mod}	10 UI _{p-p}
2 MHz f_{mod}	1 UI _{p-p}
10 MHz f_{mod}	0.5 UI _{p-p}

Trigger system

The Trigger output provides either a pattern synchronous trigger signal or a clock/n signal.

Trigger waveform	Pattern mode trigger is synced to channel 1 pattern. Pattern mode. 1 pattern per trigger for pattern length = multiple of 64 64 patterns per trigger for other pattern lengths Clock/n mode. 64 through $(2^{32} - 64)$, n = any multiple of 64 in that range Duty cycle. 50%, for either Pattern or Clock/n
High level	0 V, typical
Low level	-500 mV, typical
Output impedance	50 Ω , DC-coupled
Connector type	SMA

Clock inputs

The pattern generators allow the use of an external clock. The external clock must be a continuous 50% duty cycle clock.

Frequency range	15 GHz to 30 GHz, (PPG3000 series) 16 GHz to 32 GHz, (PPG3200 series) Not applicable for the PPG1600 series.
Input signal	400 mV _{p-p} , typical, AC coupled
Maximum input signal	1 V _{p-p}
Input impedance	50 Ω , AC-coupled

Reference clock

The reference clock provides an input and an output to lock the internal clock synthesizers to other equipment.

Input frequency range	10 MHz \pm 10 ppm
Input signal	1 V _{p-p} , typical, 50% duty square wave
Maximum input signal	6 V _{p-p} , \pm 10 V DC, Damage threshold
Input impedance	50 Ω , AC-coupled
Output signal	1.2 V _{p-p} , typical, Square wave
10 MHz reference input/output	Yes, BNC connector

Channel skew

The channel skew is the timing of the data outputs.

Skew adjust	Relative to nominal position PPG1600 and PPG3000. Range = \pm 50 ps Resolution = 100 fs PPG3200. Range = \pm 25 ps Resolution = 100 fs
Pattern shift	Advance or delay. This is equivalent to unlimited shifting since this range allows shifting the longest pattern to any position. Range. $\pm(2^{30}-1)$ Resolution. 1 bit
Nominal channel-to-channel pattern skew	$< \pm 2$ UI, Time difference between patterns on a 2-channel PPG3000 series, skew adjust and bit shift at 0.

Data error insertion

Error insertion types	Single or rate-based
Error insertion rate	Range. 1×10^{-3} to 1×10^{-15} BER
	Resolution. 3 digits

Control interfaces

Front panel touchscreen GUI	Yes, edit all instrument settings.
Computer programmable interface	USB TMC, program all instrument settings.

Physical characteristics

Front panel width (with mounting tabs)	48.3 cm (19.0 in)
Height	1 & 2 channel. 13.3 cm (5.25 in)
	4 channel. 27.9 cm (11.0 in)
Width	45.1 cm (17.75 in)
Depth (rack mount)	35.1 cm (13.8 in)
Weight	1 & 2 channel. 11.1 kg (24.5 lbs)
	4 channel. 20.4 kg (45 lbs)
Operating temperature	0 °C to 40 °C (32 °F to 104 °F)

Graphical user interface (GUI) touch screen

This unit is equipped with touch screen controls. All manual settings are accessed through this user interface. An example of the GUI is shown in the following figure.

The following table gives a listing of where to find various parameters within the menu structure.

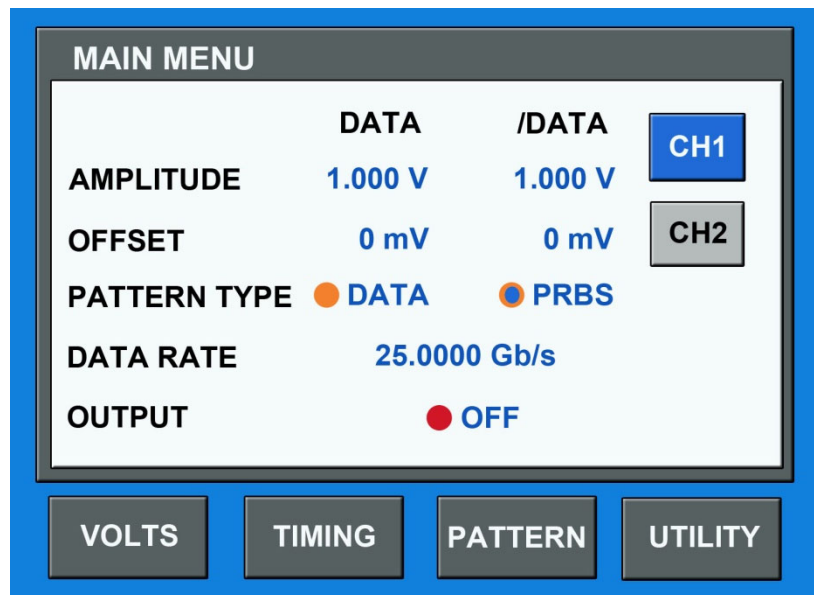

Figure 10: GUI Main menu

Table 6: GUI menu parameter locations

Parameter	Found in menu(s)
10 MHz Ref (int / ext)	UTILITY
Amplitude	MAIN, VOLTS
Crossing Point	VOLTS
Data Rate	MAIN, TIMING
External Clock Enable	TIMING [EXTFREQ]
Internal Clock Rate	TIMING
Jitter Enable	TIMING [JITTER]
Linking	VOLTS
Offset Voltage	MAIN, VOLTS
Output Clock Rate	TIMING
Pattern Length	PATTERN
Pattern Type	MAIN, PATTERN
Pattern (user defined)	PATTERN [DATA]

Table 6: GUI menu parameter locations (cont.)

Parameter	Found in menu(s)
PRBS Length	PATTERN
Output ON / OFF	MAIN, VOLTS
Recall Pattern	PATTERN [SAVE] [RECALL]
Recall Setup	UTILITY [SAVE] [RECALL]
Save Pattern	PATTERN [SAVE] [STORE]
Save Setup	UTILITY [SAVE] [STORE]
Skew	TIMING
Termination Voltage	VOLTS
Trigger Options	UTILITY [TRIGGER]

Remote programming

USB interface

All automated programming is accomplished through a USB TMC interface.

Command information

Sequential vs. overlapped

All commands for instruments covered by this document are sequential commands. Sequential commands complete before the next is executed. This means that completion of any command can be verified by following it with any query. When the query response is received, the previous command is certain to be complete.

Long and short form

Commands have both a long and short form. In command descriptions, the long form is the entire command while the short form is the part in capital letters. Commands must be either the exact long form or the exact short form, other combinations will create an error.

Channel numbers

These commands apply to instruments that are available with different numbers of channels. Commands for non-existent channels are not valid.

Common commands

Summary

Command	Description
*IDN?	Read Instrument's Identification string
*RST	Reset instrument to default settings

Reference

***IDN?** Read the instrument's identification string. The returned string has the following format, it can be up to 72 characters long:

"Tektronix Inc.Model code,SN,FWREV"

- Model code (see the following table for your instrument model.)
- SN = serial number
- FWREV = firmware revision

Table 7: Models and Model codes

Model	Model code
PPG1251	12050
PPG1601	12601
PPG1602	12602
PPG1604	12603
PPG3001	12593
PPG3002	12594
PPG3004	12595
PPG3201	12590
PPG3202	12591
PPG3204	12592
PPG4001	12604

***RST** Reset the instrument to default settings. This sets all parameters to their default values, including output enable, pattern length, and pattern data.

Regular commands

Summary

The following table provides a summary of the remote control commands.

Command	Parameters	Default	Description	
DIGITAL subsystem				
:DIGital[1 2 3 4]				
:PATtern				
:LENGth	<numeric>	8	set/query Pattern Length	(See page 34.)
:TYPE	DATA PRBS	PRBS	set/query Pattern type	(See page 34.)
:PLENGth	<numeric>	7	set/query PRBS length	(See page 35.)
:DATA	<numeric>, <numeric>, <arbitrary block>	1000...	set/query Pattern Data	(See page 36.)
:HDATA	<numeric>, <numeric>, <arbitrary block>	1000...	set/query Pattern Data in hexadecimal character format	(See page 37.)
:SERRor	none	n/a	insert a single error into the data output	(See page 38.)
:ERATE	<numeric>	1e-3	inserts error into the data output at the specified rate	(See page 38.)
:ERATE:STATe	OFF ON	OFF	enable error rate injection into the data output	(See page 38.)
:BSHift	<numeric>	0	shift the pattern by the specified number of bits relative to nominal position	(See page 39.)
:SIGNal[:POS :NEG]:CROSSover				
	[:VALue]	<numeric>	set/query crossing point	(See page 39.)
Output subsystem				
:OUTPut0				
:SOURce	PERiodic BITStream	BITS	set/query trigger out event	(See page 43.)
:DIVider	<numeric>	varies	set/query trigger divider	(See page 43.)
:OUTPut[1 2 3 4]				
:POLarity	NORMal INVerted	NORM	set/query data output polarity	(See page 44.)

Regular commands

Command	Parameters	Default	Description	
[[:STATe]	OFF ON	OFF	set/query data output enable/disable status	(See page 44.)
:OUTPut				
:CLOCK:DIVider	<numeric>	varies	programs the clock divider output for the internal clock	(See page 44.)
Sense subsystem				
:SENSe:ROSCillator				
:SOURce	INTernal EXTernal	INT	set/query 10 MHz reference source	(See page 45.)
Source subsystem				
[[:SOURce]				
:FREQuency[:CW]:FIXed]	<numeric>	16 GHz, (PPG1600) 30 GHz, (PPG3000) 32 GHz, (PPG3200)	set/query clock frequency	(See page 45.)
:SKEW#	<numeric>	0 ps	Programs the skew	(See page 45.)
PM[1 2 3 4][:HF]				
:[:STATe]	OFF ON	OFF	set/query overall jitter insertion enable/disable status	(See page 46.)
:INTernal1[:DEVIation]	<numeric>	0 ps	set/query internal HF sine jitter amplitude	(See page 46.)
:INTernal1:FREQuency	<numeric>	1 MHz	set/query internal HF sine jitter frequency	(See page 46.)
:INTernal1:STATe	OFF ON	OFF	set/query internal HF sine jitter enable/disable status	(See page 47.)
:INTernal2[:DEVIation]	<numeric>	0 ps	set/query internal random jitter amplitude	(See page 49.)
:INTernal2:STATe	OFF ON	OFF	set/query internal random jitter enable/disable status	(See page 48.)
:INTernal4:CALibration	GAUSSian CEI	GAUS	set/query BUJ amplitude cal	(See page 48.)
:INTernal4[:DEVIation]	<numeric>	0 ps	set/query internal HF BUJ jitter amplitude	(See page 49.)
INTernal4:FILTer	<numeric>	100 MHz	set/query internal HF BUJ generator filter bandwidth	(See page 49.)

Command	Parameters	Default	Description	
:INternal4:FREQuency	<numeric>	2 GHz	set/query internal HF BUJ generator clock frequency	(See page 49.)
:INternal4:PLENght	<numeric>	31	set/query internal HF BUJ generator PRBS length	(See page 49.)
:INternal4:STATe	OFF ON	OFF	set/query internal HF BUJ jitter enable/disable status	(See page 50.)
:PM:LF				
[:INternal3][:DEViation]	<numeric>	0 UI	set/query internal LF sine jitter amplitude	(See page 50.)
[:INternal3]:FREQuency	<numeric>	10 kHz	set/query internal LF sine jitter frequency	(See page 50.)
[:INternal3]:STATe	OFF ON	OFF	set/query internal LF sine jitter enable/disable status	(See page 50.)
:VOLTage#[:POS]:NEG][:LEVel][:IMMediate]				
[::AMPLitude]	<numeric>	500 mV	set/query data amplitude	(See page 51.)
:OFFSet	<numeric>	0 V	set/query data offset	(See page 51.)
:TERMination	<numeric>	0 V	set/query data term	(See page 51.)
:VOLTage#[:LEVel][:IMMediate]				
:LINK	OFF ON	OFF	Enable/disable Linking	(See page 52.)
System subsystem				
:SYSTem:ERRor[:NEXT]?	none	n/a	query error queue	(See page 52.)
Trigger subsystem				
:TRIGger				
:SOURce	IMMediate EXTernal	IMM	set/query clock source	(See page 53.)
:LOCK	none	n/a	set/query clock source	(See page 53.)

Reference

:DIGital[1|2|3|4]:PATtern:LENGth

Form	Set & Query
Parameters	Numeric
Value Coupling	None
Range Coupling	None
Default	8
Description	<p>Programs the Pattern Length. This value is only relevant if the pattern type is DATA. For the one channel instruments, the length may be any integer from 2 through 4,194,304. In a two or four channel unit, the maximum pattern length per channel is 2,097,152.</p>
Example	<pre>Set Ch1 pattern length to 56 :DIG1:PATT:LENG 56 Set Ch2 pattern length to 500 :DIG2:PATT:LENG 500 Query Ch 1 pattern length :DIG1:PATT:LENG?</pre>

:DIGital[1|2|3|4]:PATtern:TYPE

Form	Set & Query
Parameters	DATA PRBS
Value Coupling	None
Range Coupling	None
Default	PRBS
Description	Programs the Pattern Type.
Example	<pre>Set the Ch 1 pattern type to PRBS :DIG1:PATT:TYPE PRBS Query Ch 1 pattern type :DIG1:PATT:TYPE?</pre>

:DIGital[1|2|3|4]:PATTern:PLENgtH

Form	Set & Query
Parameters	7 9 11 15 23 31
Value Coupling	None
Range Coupling	None
Default	7
Description	Programs the Pattern PRBS Length. PRBS Length is specified as 2^N-1 , where N is the specified value. This value is only relevant if the pattern type is PRBS.
Example	Set the Ch 1 PRBS length to (2^7-1) : DIG1: PATT: PLEN 7 Query Ch1 PRBS length : DIG1: PATT: PLEN?

:DIGital[1|2|3|4]:PATtern:DATA

Form	Set & Query
Parameters	<p><start address>,<bit count>,<data></p> <p><start address> is numeric, and is the bit number in pattern data memory of the first bit to write.</p> <p><bit count> is the number of bits to write into pattern data memory.</p> <p><data> is an arbitrary block of program data as defined in IEEE-488.2-1992, section 7.7.6.2. It starts with a "#" character, followed by a single character representing the length of the length, then 1 to 5 characters specifying the length as a decimal number, then the program data.</p>
Value Coupling	None
Range Coupling	None
Default	Default data is a 1 in position 1, all other bits are 0.
Description	<p>Programs the pattern data memory. Each byte of pattern data is a character (0 or 1) representing one bit of pattern data. The start address can be any bit location, 1 – <max address>. <max address> is > is 4,194,304 for one-channel instruments and 2,097,152 for a two-channel and four-channel instruments. The bit count can be any number 1 – 1024. The entire pattern data memory is accessible for reads or writes, even outside the range of the current pattern length setting. The bit count parameter and the length of the data block must match. (<start address> + <bit count>) must be ≤ (<max address> + 1).</p>
Example	<pre>:DIG1:PATT:DATA 1,16,#2160100000101010010</pre> <p>This command does the following:</p> <ul style="list-style-type: none"> Starts loading the Ch 1 data into bit location 1. Specifies that 16 bits of data will be loaded. <p>In the <data>:</p> <ul style="list-style-type: none"> #: signifies the beginning of the block 2: indicates that the length of the data length is two characters 16: indicates that data length is 16 bytes. (16 ASCII characters) 0100000101010010: is the character representation of the data <p>Thus, bits 1 through 16 in the channel 1 pattern data memory will be set to 0100000101010010.</p> <pre>:DIG1:PATT:DATA? 1,8</pre> <p>This query reads 8 bits of channel 1 pattern data starting from address 1. Given the above pattern data memory contents, the response would be "#1801000001".</p>

:DIGital[1|2|3|4]:PATtern:HDATa

Form	Set & Query
Parameters	<p><start address>,<bit count>,<data></p> <p><start address> is numeric, and is the bit number in pattern data memory of the first bit to write.</p> <p><bit count> is the number of bits to write into pattern data memory.</p> <p><data> is an arbitrary block of program data as defined in IEEE-488.2-1992, section 7.7.6.2. It starts with a "#" character, followed by a single character representing the length of the length, then 1 to 5 characters specifying the length as a decimal number, then the program data.</p>
Value Coupling	None
Range Coupling	None
Default	Default data is a 1 in position 1, all other bits are 0.
Description	<p>Programs the pattern data memory using hexadecimal character format. Each byte of pattern data is a hexadecimal character (0-9, A-F or a-f) representing four bits of pattern data. The start address can be any bit location, 1 – <max address>. <max address> is 4,194,304 for one-channel instruments and 2,097,152 for a two-channel and four-channel instruments. The bit count can be any number 1 – 4096. The entire pattern data memory is accessible for reads or writes, even outside the range of the current pattern length setting.</p> <p>The bit count parameter must be equal to 4 times the length of the data block or up to 3 bits fewer. If it is fewer, then the extra bits in the last data byte are ignored. (<start address> + <bit count>) must be ≤ (<max address> + 1).</p>
Example	<p>:DIG1:PATT:HDAT 1,16,#144152</p> <p>This command does the following:</p> <ul style="list-style-type: none"> Starts loading the Ch 1 data into bit location 1. Specifies that 16 bits of data will be loaded. <p>In the <data>:</p> <ul style="list-style-type: none"> #: signifies the beginning of the block 1: indicates that the length of the data length is one character 4: indicates that data length is 4 bytes. (4 ASCII characters) 4152: is the character representation of the data <p>Thus, bits 1 through 16 in the channel 1 pattern data memory will be set to 0100000101010010.</p> <p>:DIG1:PATT:HDAT? 1,8</p> <p>This query reads 8 bits of channel 1 pattern data starting from address 1. Given the above pattern data memory contents, the response would be "#1241".</p> <p>Note that if the query requests a number of bits that is not a multiple of 4, some bits in the last byte will not be meaningful, and will be 0.</p>

:DIGital[1|2|3|4]:PATtern:SERRor

Form	Set
Parameters	None
Value Coupling	None
Range Coupling	None
Default	n/a
Description	Inserts a single error into the data output. Error insertion works for either data patterns or PRBS patterns. If there is no pattern currently being output, for instance if the outputs are disabled, the command has no effect.
Example	Insert one error into the Ch 1 data output. :DIG1:PATT:SERROR

:DIGital[1|2|3|4]:PATtern:ERATe

Form	Set & Query
Parameters	Numeric
Value Coupling	None
Range Coupling	None
Default	1e-3
Description	Insert errors into the data output at the specified rate. Error rate insertion works for either data patterns or PRBS patterns when error rate is enabled.
Example	Insert 2E-12 error rate into the Ch 1 data output. :DIG1:PATT:ERAT 2e-12

:DIGital[1|2|3|4]:PATtern:ERATe:STATe

Form	Set & Query
Parameters	OFF ON
Value Coupling	None
Range Coupling	None
Default	OFF
Description	Enables insertion of errors into the data output at a rate specified by the :DIGital[1 2 3 4]:PATtern:ERATe command.
Example	Enable error insertion rate into the Ch 1 data output. :DIG1:PATT:ERAT:STAT ON

:DIGital[1|2|3|4]:PATTern:BSHift

Form	Set & Query
Parameters	Numeric
Value Coupling	None
Range Coupling	None
Default	0
Description	Shift the pattern by the specified number of bits relative to nominal position.
Example	Insert bit shift of 10 into the Ch 1 data output. :DIG1:PATT:BSH 10

:DIGital[1|2|3|4]:SIGNal[:POS|:NEG]:CROSSover:[VALue]

Form	Set & Query
Parameters	Numeric [no units, value is in %]
Value Coupling	None
Range Coupling	None
Default	50 %
Description	This feature is available for the PPG1600 and PPG3000 series only. Programs the NRZ signal crossing point. Positive (Data out) and negative outputs (Data out Bar) have independent crossing point adjustment, specified by [:POS :NEG]. Note: to maintain normal complement behavior, if the POS output crossing point is set to 50+X, then the NEG should be set to 50-X. For example, if the POS were set to 57%, the NEG would be set to 43%.
Example	Set Ch 1 negative output crossing point to 45%. :DIG1:SIGN:NEG:CROS 45

:MMEMory:STORe:PDATa

Form	Set
Parameters	String
Value Coupling	None
Range Coupling	None
Default	N/A
Description	Store the current pattern data into the system memory. In a multi-channel unit, the pattern data running on all channels are stored. The pattern length and all pattern data up to the pattern length are stored. The filename can be up to 8 characters long and is not case-sensitive. Filenames must consist of only alphanumeric characters.
Example	Store the pattern data in system memory. :MMEM:STOR:PDAT "PATT1011"

:MMEMory:STORe:STATe

Form	Set
Parameters	String
Value Coupling	None
Range Coupling	None
Default	N/A
Description	Store the instrument setting into the system memory. Every parameter of the instrument is stored except for pattern data, pattern length and output enable status. The filename can be up to 8 characters long and is not case-sensitive. Filenames must consist of only alphanumeric characters.
Example	Store the parameters in system memory. :MMEM:STOR:STAT "PARAM22"

:MMEMory:LOAD:PDATa

Form	Set
Parameters	String
Value Coupling	None
Range Coupling	None
Default	N/A
Description	Recalls the pattern data from a saved file in system memory. In a multi-channel unit, the pattern data of all channels are recalled. The pattern length and all data up to the pattern length are recalled. Pattern memory addresses above the pattern length are not changed. The filename can be up to 8 characters long and is not case-sensitive. Filenames must consist of only alphanumeric characters.
Example	Recall the pattern data from file "PATT1011". MMEM:LOAD:PDAT "PATT1011"

:MMEMory:LOAD:STATe

Form	Set
Parameters	String
Value Coupling	None
Range Coupling	None
Default	N/A
Description	Recalls the instrument setting from a saved file in system memory. Every parameter of the instrument is recalled except for pattern data, pattern length and output enable status. The filename can be up to 8 characters long and is not case-sensitive. Filenames must consist of only alphanumeric characters.
Example	Recall the instrument settings from file "PARAM22". :MMEM:LOAD:STAT "PARAM22"

:MMEMory:MOVE:PDATa

Form	Set
Parameters	String
Value Coupling	None
Range Coupling	None
Default	N/A
Description	Rename the existing saved pattern data file in system memory. The filename can be up to 8 characters long and is not case-sensitive. Filenames must consist of only alphanumeric characters.
Example	Rename the pattern data file PATT1011 to PATT0101. :MMEM:MOVE:PDAT "PATT1011", "PATT0101"

:MMEMory:MOVE:STATe

Form	Set
Parameters	String
Value Coupling	None
Range Coupling	None
Default	N/A
Description	Rename the existing saved instrument settings file in system memory. The filename can be up to 8 characters long and is not case-sensitive. Filenames must consist of only alphanumeric characters.
Example	Rename the instrument settings file PARAM22 to PARAM. :MMEM:MOVE:STAT "PARAM22", "PARAM"

:MMEMory:DELeTe:PDATa

Form	Set
Parameters	String
Value Coupling	None
Range Coupling	None
Default	N/A
Description	Deletes an existing saved pattern data file in system memory. The filename can be up to 8 characters long and is not case-sensitive. Filenames must consist of only alphanumeric characters.
Example	Delete the existing pattern data file PATT0101. :MMEM:DEL:PDAT "PATT0101"

:MMEMory:DELeTe:STATe

Form	Set
Parameters	String
Value Coupling	None
Range Coupling	None
Default	N/A
Description	Deletes an existing saved instrument settings file in system memory. The filename can be up to 8 characters long and is not case-sensitive. Filenames must consist of only alphanumeric characters.
Example	Delete the existing instrument settings file PARAM. :MMEM:DEL:STAT "PARAM"

:MMEMory:CATalog:PDATa?

Form	Query
Parameters	None
Value Coupling	None
Range Coupling	None
Default	N/A
Description	Get the list of pattern data files stored in system memory. All the filenames stored in the system memory are returned as capital letters.
Example	Get the list of pattern data files stored in system memory. :MMEM:CAT:PDAT?

:MMEMory:CATalog:STATe?

Form	Query
Parameters	None
Value Coupling	None
Range Coupling	None
Default	N/A
Description	Get the list of instrument settings files stored in system memory. All the filenames stored in the system memory are returned as capital letters.
Example	Get the list of instrument settings files stored in system memory. :MMEM:CAT:STAT?

:OUTPut0:SOURce

Form	Set & Query
Parameters	PERiodic BITStream
Value Coupling	None
Range Coupling	None
Default	PERiodic
Description	<p>Programs the trigger out event.</p> <p>PERiodic means the trigger will output a signal whose frequency is the clock rate divided by N, where N is the trigger divider setting.</p> <p>BITStream means trigger pulses will be aligned with the pattern length.</p>
Example	Set the trigger out event to bit stream. :OUTP0:SOUR BITSTREAM

:OUTPut0:DIVider

Form	Set & Query
Parameters	Numeric
Value Coupling	None
Range Coupling	None
Default	64
Description	Programs the trigger divider. This is meaningful only if the trigger output event is set to <i>periodic</i> .
Example	Set the trigger divider to 128. :OUTP0:DIV 128

:OUTPut[1|2|3|4]:POLarity

Form	Set & Query
Parameters	NORMal INVerted
Value Coupling	None
Range Coupling	None
Default	NORMal
Description	Programs the polarity of the channel outputs.
Example	Set Ch 1 for inverted output :OUTPUT1:POLARITY INV

:OUTPut[1|2|3|4][:STATE]

Form	Set & Query
Parameters	OFF ON
Value Coupling	None
Range Coupling	None
Default	OFF
Description	Programs the enable/disable status of the channel outputs.
Example	Disable the Ch 1 output. :OUTP1 OFF

:OUTPut:CLOCK:DIVider

Form	Set & Query
Parameters	1 2 4 8 16
Value Coupling	None
Range Coupling	None
Default	Varies with model and options. The minimum allowed value is either 1 or 2.
Description	Programs the clock output divider. The input to this divider is internal clock, and the output from the divider goes to the clock output or to the divided clock output if the full rate and divided outputs are separate. The maximum and minimum valid values depend on the instrument model and options.
Example	Program clock divider for 8. :OUTP:CLOC:DIV 8

:SENSe:ROSCillator:SOURce

Form	Set & Query
Parameters	INTernal EXTernal
Value Coupling	None
Range Coupling	None
Default	INT
Description	Programs the 10 MHz reference source.
Example	Set the 10 MHz reference source to use the internal reference. :SENSe:ROSCILLATOR:SOURCE INTERNAL

[:SOURce]:FREQuency[:CW|:FIXed]

Form	Set & Query
Parameters	Numeric [Hz]
Value Coupling	None
Range Coupling	None
Default	16e9 for PPG1600 series 30e9 for PPG3000 series 32e9 for PPG3200 series
Description	Programs the internal clock frequency, and also selects the internal clock as clock source if it is not already selected.
Example	Set frequency to 28 GHz. :FREQ 28e9

[:SOURce]:SKEW[1|2|3|4]

Form	Set & Query
Parameters	Numeric [ps]
Value Coupling	None
Range Coupling	None
Default	0 ps
Description	Programs the skew.
Example	Set the channel 1 skew to 20 ps. :SKEW 20e-12

[:SOURce]:PM[1|2|3|4][:HF][:STATe]

Form	Set & Query
Parameters	OFF ON
Value Coupling	None
Range Coupling	None
Default	OFF
Description	Programs the overall channel jitter insertion enable/disable status. The HF sources are HF sine, random and external. If enabled, the external jitter source is enabled and the internal sources are set according to their individual controls.
Example	Enable channel 1 overall HF jitter insertion. : PM1 ON

[:SOURce]:PM[1|2|3|4][:HF]:INTernal1[:DEViation]

Form	Set & Query
Parameters	Numeric [S]
Value Coupling	None
Range Coupling	None
Default	0 ps
Description	Programs the peak-to-peak amplitude of the channel internal sine jitter source. Units are in seconds.
Example	Set the channel 1 internal HF sine jitter source to 11 ps peak-to-peak. : PM1:INT1 11ps

[:SOURce]:PM[1|2|3|4][:HF]:INTernal1:FREQuency

Form	Set & Query
Parameters	Numeric [Hz]
Value Coupling	None
Range Coupling	None
Default	1 MHz
Description	Programs the frequency of the channel internal HF sine jitter source. Units are Hz.
Example	Set channel 1 sinusoidal jitter frequency to 1.3 MHz. : PM1:INT1:FREQ 1.3MHz

[[:SOURce]:PM[1|2|3|4]:HF]:INTernal1:STATE

Form	Set & Query
Parameters	OFF ON
Value Coupling	None
Range Coupling	None
Default	OFF
Description	Programs the channel internal HF sine jitter source enable/disable status. Both this setting and [[:SOURce]:PM[1 2 3 4]:HF]:STATE] for a given channel must be on for HF sine jitter to be applied.
Example	Enable the channel 1 internal HF sine jitter source. :PM1:INTERNAL1:STATE ON

[[:SOURce]:PM[1|2|3|4]:HF]:INTernal2[:DEViation]

Form	Set & Query
Parameters	Numeric [S]
Value Coupling	None
Range Coupling	None
Default	0 ps
Description	Programs the rms amplitude of the channel internal random jitter source. Units are in seconds.
Example	Set the channel 1 internal random jitter source to 7 ps rms. :PM1:INT2 7ps

[[:SOURce]:PM[1|2|3|4]:HF]:INTernal2:STATE

Form	Set & Query
Parameters	OFF ON
Value Coupling	None
Range Coupling	None
Default	OFF
Description	Programs the channel internal random jitter source enable/disable status. Both this setting and [[:SOURce]:PM[1 2 3 4]:HF]:STATE] for a given channel must be on for random jitter to be applied.
Example	Disable the channel 1 internal random jitter source. :PM1:INTERNAL2:STATE OFF

[:SOURce]:PM[1|2|3|4][:HF]:INTernal4:CALibration

Form	Set & Query												
Parameters	GAUSSian CEI												
Value Coupling	None												
Range Coupling	None												
Default	GAUS												
Description	<p>Programs the calibration source for the BUJ amplitude. BUJ amplitude is calibrated under two conditions; select the source closest to the current settings. The settings for each cal are given below.</p> <table border="1"> <thead> <tr> <th></th> <th><i>Frequency</i></th> <th><i>Filter</i></th> <th><i>Plength</i></th> </tr> </thead> <tbody> <tr> <td>Gaussian</td> <td>2 Gb/s</td> <td>100 MHz</td> <td>31</td> </tr> <tr> <td>CEI</td> <td>1.1 Gb/s</td> <td>100 MHz</td> <td>7</td> </tr> </tbody> </table>		<i>Frequency</i>	<i>Filter</i>	<i>Plength</i>	Gaussian	2 Gb/s	100 MHz	31	CEI	1.1 Gb/s	100 MHz	7
	<i>Frequency</i>	<i>Filter</i>	<i>Plength</i>										
Gaussian	2 Gb/s	100 MHz	31										
CEI	1.1 Gb/s	100 MHz	7										
Example	<p>Select the CEI calibration for channel 2.</p> <pre>:PM2:INTERNAL4:CAL CEI</pre>												

[:SOURce]:PM[1|2|3|4][:HF]:INTernal4[:DEViation]

Form	Set & Query
Parameters	Numeric [S]
Value Coupling	None
Range Coupling	None
Default	0 ps
Description	<p>Programs the peak-to-peak amplitude of the channel internal BUJ jitter source. Units are Seconds.</p>
Example	<p>Set the channel 1 internal BUJ random jitter source to 12 ps peak-to-peak.</p> <pre>:PM1:INT4 12ps</pre>

[:SOURce]:PM[1|2|3|4][:HF]:INTernal4:FILTer

Form	Set & Query
Parameters	Numeric [Hz]
Value Coupling	None
Range Coupling	None
Default	100 MHz
Description	<p>Programs the bandwidth of the low-pass filter used to generate the BUJ jitter. Units are Hz. Valid values are 25 MHz, 50 MHz, or 100 MHz. Other values will be rounded to the nearest valid value.</p>
Example	<p>Set the channel 3 internal BUJ low-pass filter to 50 MHz.</p> <pre>:PM3:HF:INT4:FILTER 50MHZ</pre>

[[:SOURce]:PM[1|2|3|4]:[:HF]:INTernal4:FREQuency

Form	Set & Query
Parameters	Numeric [Hz]
Value Coupling	None
Range Coupling	None
Default	2 GHz
Description	Programs the clock frequency of the PRBS used to generate the BUJ jitter. Units are Hz.
Example	Set clock frequency of the channel 1 BUJ PRBS to 1.7 GHz. :PM1:INT4:FREQ 1.7GHz

[[:SOURce]:PM[1|2|3|4]:[:HF]:INTernal4:PLENght

Form	Set & Query
Parameters	7 9 11 15 23 31
Value Coupling	None
Range Coupling	None
Default	31
Description	Programs the length of the PRBS used to generate the BUJ jitter. PRBS Length is specified as 2^N-1 , where N is the specified value.
Example	Set PRBS Length of the channel 2 BUJ PRBS to $(2^{15}-1)$. :PM2:INT4:PLEN 15

[[:SOURce]:PM[1|2|3|4]:[:HF]:INTernal4:STATe

Form	Set & Query
Parameters	OFF ON
Value Coupling	None
Range Coupling	None
Default	OFF
Description	Programs the channel internal BUJ jitter source enable/disable status. Both this setting and [[:SOURce]:PM[1 2 3 4]:[:HF]:STATe] for a given channel must be on for BUJ jitter to be applied.
Example	Disable the channel 1 internal BUJ jitter source. :PM1:INTERNAL4:STATE OFF

[:SOURce]:PM:LF[:INTernal3][:DEVIation]

Form	Set & Query
Parameters	Numeric [UI]
Value Coupling	None
Range Coupling	LF Sine Jitter Frequency
Default	0 UI
Description	Programs the peak-to-peak amplitude of the internal LF sine jitter source. Units are UI. Maximum allowed value depends on LF Sine Jitter Frequency. LF jitter is common to all channels.
Example	Set the internal LF sine jitter source to 2.5 UI peak-to-peak. :PM:LF:INT3 2.5

[:SOURce]:PM:LF[:INTernal3]:FREQUency

Form	Set & Query
Parameters	Numeric [Hz]
Value Coupling	None
Range Coupling	LF Sine Jitter Amplitude
Default	10 kHz
Description	Programs the frequency of the internal LF sine jitter source. Units are Hz. Allowed range depends on LF Sine Jitter Amplitude. LF jitter is common to all channels.
Example	Set the LF sinusoidal jitter frequency to 7.3 kHz. :PM:LF:INT3:FREQ 7300

[:SOURce]:PM:LF[:INTernal3]:STATe

Form	Set & Query
Parameters	OFF ON
Value Coupling	None
Range Coupling	None
Default	OFF
Description	Programs the internal LF sine jitter source enable/disable status. LF jitter is common to all channels.
Example	Enable the internal LF sine jitter source. :PM:LF:INTERNAL3:STATE ON

[[:SOURce]:VOLTage[1|2|3|4][:POS|:NEG][:LEVel][:IMMediate]:[:AMPLitude]

Form	Set & Query
Parameters	Numeric [V]
Value Coupling	None
Range Coupling	Offset
Default	500 mV
Description	Programs the amplitude of the output signal for the channel's positive or negative data outputs. This feature is not available with Option FXD.
Example	Set Ch 1 positive data amplitude to 1V. :VOLT1:POS 1V

[[:SOURce]:VOLTage[1|2|3|4][:POS|:NEG][:LEVel][:IMMediate]:OFFSet

Form	Set & Query
Parameters	Numeric [V]
Value Coupling	None
Range Coupling	Amplitude
Default	0 V
Description	Programs the offset of the output signal for the channel's positive or negative data outputs. This feature is not available with Option FXD.
Example	Set Ch 1 negative data offset to -0.5V. :VOLT1:NEG:OFFS -0.5V

[[:SOURce]:VOLTage[1|2|3|4][:POS|:NEG][:LEVel][:IMMediate]:TERMination

Form	Set & Query
Parameters	Numeric [V]
Value Coupling	None
Range Coupling	Amplitude, Offset
Default	0 V
Description	Programs the user-supplied external termination voltage for the channel's positive or negative data outputs. This feature is not available with Option FXD.
Example	Set Ch 1 positive term voltage to -1.0 V. :VOLT1:POS:TERM -1.0V

[:SOURce]:VOLTage[1|2|3|4][:LEVel][:IMMediate]:LINK

Form	Set & Query
Parameters	None
Value Coupling	None
Range Coupling	Amplitude, Offset, termination voltage
Default	OFF
Description	When linking is on, the true and complement values for amplitude, offset and termination of the channels are coupled together. This feature is not available with Option FXD.
Example	Disable linking between Ch1 data out and Ch1 data out complement. :VOLT1:LINK OFF

:SYSTem:ERRor[:NEXT]?

Form	Query
Parameters	None
Value Coupling	N/A
Range Coupling	N/A
Default	N/A
Description	Queries the system error queue. Returns an integer representing the error number and a string in double quotes containing the error description. The integer and string are separated by a comma. The error queue may have multiple items that can be retrieved using multiple queries. If the queue is empty, the response will be: +0,"No error". If the queue receives more errors than it can hold, the extra errors will be discarded.
Example	Query the error queue. :SYST:ERR?

:TRIGger:SOURce

Form	Set and Query
Parameters	IMMediate EXTernal
Value Coupling	N/A
Range Coupling	N/A
Default	IMMediate
Description	<p>Programs the clock source.</p> <p>IMMediate means the internal clock source provides the clock. Clock frequency is set by the [:SOURce]:FREQuency[:CW]:FIXed] command.</p> <p>EXTernal means the signal at the Ext Clock connector provides the clock source. Clock frequency is equal to the frequency of the external signal.</p> <p>After changing to external clock source the generator must be locked to the clock. If external clock source is in use, the generator must be re-locked to the clock after any interruption or change in frequency of the clock. The lock process must be successfully completed for the generator to function properly. See the :TRIGger:LOCK command. (See page 53, :TRIGger:LOCK.)</p> <p>This command is not available with the PPG1601, PPG1602, or PPG1604.</p>
Example	<p>Set the clock source to internal.</p> <pre>:TRIG:SOUR IMM</pre>

:TRIGger:LOCK

Form	Set
Parameters	None
Value Coupling	N/A
Range Coupling	N/A
Default	N/A
Description	<p>Initiates the process of locking the generator to the external clock.</p> <p>After changing to external clock source the generator must be locked to the clock. If external clock source is in use, the generator must be re-locked to the clock after any interruption or change in frequency of the clock. The lock process must be successfully completed for the generator to function properly.</p> <p>This command is not available with the PPG1601, PPG1602, or PPG1604.</p>
Example	<p>Lock the generator to the external clock.</p> <pre>:TRIG:LOCK</pre>

User service

This section describes high-level service information and procedures for your instrument.

Service offerings

Tektronix provides service to cover repair under warranty and other services that are designed to meet your specific service needs.

Whether providing warranty repair service or any of the other services listed below, Tektronix service technicians are well equipped to service your instruments. Services are provided at Tektronix Service Centers and on-site at your facility, depending on your location.

Warranty repair service

Tektronix warrants this product as described in the warranty statements at the front of this manual. Tektronix technicians provide warranty service at most Tektronix service locations worldwide. The Tektronix product catalog lists all service locations worldwide.

Calibration and repair service

In addition to warranty repair, Tektronix Service offers calibration and other services that provide cost-effective solutions to your service needs and quality standards compliance requirements. Tektronix instruments are supported worldwide by the leading-edge design, manufacturing, and service resources of Tektronix to provide the best possible service.

General care

Protect the instrument from adverse weather conditions. The instrument is not waterproof. Do not store or leave the instrument where the display will be exposed to direct sunlight for long periods of time.



CAUTION. *To avoid damage to the instrument, do not expose it to sprays, liquids, or solvents.*

Preventive maintenance

Preventive maintenance mainly consists of periodic cleaning. Periodic cleaning reduces instrument breakdown and increases reliability. Clean the instrument as needed, based on the operating environment. Dirty conditions may require more frequent cleaning than computer room conditions.

Clean the flat panel display

The flat panel display is a soft plastic display and must be treated with care during cleaning.



CAUTION. *Improper cleaning agents or methods can damage the flat panel display.*

- Do not use abrasive cleaners or commercial glass cleaners to clean the display surface.
- Do not spray liquids directly on the display surface.
- Do not scrub the display with excessive force.
- Avoid getting moisture inside the instrument while cleaning the display; use only enough solution to dampen the wipe.
- Clean the flat panel display surface by gently rubbing the display with a cleanroom wipe (such as Wypall Medium Duty Wipes, #05701, available from Kimberly-Clark Corporation).
- If the display is very dirty, moisten the wipe with distilled water or a 75% isopropyl alcohol solution and gently rub the display surface. Avoid using excess force or you may damage the plastic display surface.

Clean the exterior surfaces

Clean the exterior surfaces with a dry, lint-free cloth or a soft-bristle brush. If dirt remains, use a cloth or swab dampened with a 75% isopropyl alcohol solution. A swab is useful for cleaning in narrow spaces around the controls and connectors. Do not use abrasive compounds on any part of the instrument.

To avoid damaging the instrument follow these precautions:

- Avoid getting moisture inside the instrument during external cleaning and use only enough solution to dampen the cloth or swab.
- Do not wash the front-panel power switch. Cover the switch while washing the instrument.
- Use only deionized water when cleaning. Use a 75% isopropyl alcohol solution as a cleanser and rinse with deionized water.
- Do not use chemical cleaning agents; they may damage the instrument. Avoid chemicals that contain benzene, toluene, xylene, acetone, or similar solvents.

Battery information

The coin cell battery on the instrument computer motherboard is not a user replaceable part. The coin cell battery is not rechargeable. Under no circumstances attempt to recharge the battery.

Fuse replacement

The instrument is protected by a fuse placed in series with the power line input. The fuse is conservatively rated and should never open through the life of the instrument. A blown fuse would generally indicate a problem with the instrument which requires factory service. It is recommended that you arrange to have the instrument serviced if you experience a blown fuse.

Repack the instrument for shipment

If the instrument is to be shipped to a Tektronix service center for repair, attach a tag showing the following information:

- Name of the product owner
- Address of the owner
- Instrument serial number
- A description of the problems encountered and/or service required

When packing an instrument for shipment, use the original packaging. If it is unavailable or not fit for use, contact your Tektronix representative to obtain new packaging.

Compliance information

This section lists the EMC (electromagnetic compliance), safety, and environmental standards with which the instrument complies.

EMC compliance

EC Declaration of Conformity – EMC

Meets intent of Directive 2004/108/EC for Electromagnetic Compatibility. Compliance was demonstrated to the following specifications as listed in the Official Journal of the European Communities:

EN 61326-1. EMC requirements for electrical equipment for measurement, control, and laboratory use.^{1 2 3}

- CISPR 11. Radiated and conducted emissions, Group 1, Class A
- IEC 61000-4-2. Electrostatic discharge immunity
- IEC 61000-4-3. RF electromagnetic field immunity
- IEC 61000-4-4. Electrical fast transient / burst immunity
- IEC 61000-4-5. Power line surge immunity
- IEC 61000-4-6. Conducted RF immunity
- IEC 61000-4-11. Voltage dips and interruptions immunity

EN 61000-3-2. AC power line harmonic emissions

EN 61000-3-3. Voltage changes, fluctuations, and flicker

European contact.

Tektronix UK, Ltd.
Western Peninsula
Western Road
Bracknell, RG12 1RF
United Kingdom

¹ This product is intended for use in nonresidential areas only. Use in residential areas may cause electromagnetic interference.

² Emissions which exceed the levels required by this standard may occur when this equipment is connected to a test object.

³ For compliance with the EMC standards listed here, high quality shielded interface cables should be used.

**Australia / New Zealand
Declaration of
Conformity – EMC**

Complies with the EMC provision of the Radiocommunications Act per the following standard, in accordance with ACMA:

- CISPR 11. Radiated and Conducted Emissions, Group 1, Class A, in accordance with EN 61326-1.

Australia / New Zealand contact.

Baker & McKenzie
Level 27, AMP Centre
50 Bridge Street
Sydney NSW 2000, Australia

Safety compliance

This section lists the safety standards with which the product complies and other safety compliance information.

**EU declaration of
conformity – low voltage**

Compliance was demonstrated to the following specification as listed in the Official Journal of the European Union:

Low Voltage Directive 2006/95/EC.

- EN 61010-1. Safety Requirements for Electrical Equipment for Measurement, Control, and Laboratory Use – Part 1: General Requirements.

**U.S. nationally recognized
testing laboratory listing**

- UL 61010-1. Safety Requirements for Electrical Equipment for Measurement, Control, and Laboratory Use – Part 1: General Requirements.

Canadian certification

- CAN/CSA-C22.2 No. 61010-1. Safety Requirements for Electrical Equipment for Measurement, Control, and Laboratory Use – Part 1: General Requirements.

Additional compliances

- IEC 61010-1. Safety Requirements for Electrical Equipment for Measurement, Control, and Laboratory Use – Part 1: General Requirements.

Equipment type

Test and measuring equipment.

Safety class

Class 1 – grounded product.

Pollution degree descriptions	<p>A measure of the contaminants that could occur in the environment around and within a product. Typically the internal environment inside a product is considered to be the same as the external. Products should be used only in the environment for which they are rated.</p> <ul style="list-style-type: none">■ Pollution degree 1. No pollution or only dry, nonconductive pollution occurs. Products in this category are generally encapsulated, hermetically sealed, or located in clean rooms.■ Pollution degree 2. Normally only dry, nonconductive pollution occurs. Occasionally a temporary conductivity that is caused by condensation must be expected. This location is a typical office/home environment. Temporary condensation occurs only when the product is out of service.■ Pollution degree 3. Conductive pollution, or dry, nonconductive pollution that becomes conductive due to condensation. These are sheltered locations where neither temperature nor humidity is controlled. The area is protected from direct sunshine, rain, or direct wind.■ Pollution degree 4. Pollution that generates persistent conductivity through conductive dust, rain, or snow. Typical outdoor locations.
Pollution degree rating	Pollution degree 2 (as defined in IEC 61010-1). Rated for indoor, dry location use only.
Measurement and overvoltage category descriptions	<p>Measurement terminals on this product may be rated for measuring mains voltages from one or more of the following categories (see specific ratings marked on the product and in the manual).</p> <ul style="list-style-type: none">■ Category II. Circuits directly connected to the building wiring at utilization points (socket outlets and similar points).■ Category III. In the building wiring and distribution system.■ Category IV. At the source of the electrical supply to the building. <hr/> <p>NOTE. <i>Only mains power supply circuits have an overvoltage category rating. Only measurement circuits have a measurement category rating. Other circuits within the product do not have either rating.</i></p> <hr/>
Mains overvoltage category rating	Overvoltage category II (as defined in IEC 61010-1).

Environmental considerations

This section provides information about the environmental impact of the product.

Product end-of-life handling

Observe the following guidelines when recycling an instrument or component:

Equipment recycling. Production of this equipment required the extraction and use of natural resources. The equipment may contain substances that could be harmful to the environment or human health if improperly handled at the product's end of life. To avoid release of such substances into the environment and to reduce the use of natural resources, we encourage you to recycle this product in an appropriate system that will ensure that most of the materials are reused or recycled appropriately.



This symbol indicates that this product complies with the applicable European Union requirements according to Directives 2012/19/EU and 2006/66/EC on waste electrical and electronic equipment (WEEE) and batteries. For information about recycling options, check the Support/Service section of the Tektronix Web site (www.tektronix.com).

Restriction of hazardous substances

This product is classified as an industrial monitoring and control instrument, and is not required to comply with the substance restrictions of the recast RoHS Directive 2011/65/EU until July 22, 2017.

Index

A

accessories, 1

B

battery information, 57

block diagram, 14

C

channel skew specifications, 25

cleaning

 exterior, 56

 flat panel display, 56

clock input specifications, 24

clock output specifications, 20

command information

 channel numbers, 29

 long and short form, 29

 sequential vs. overlapped, 29

common commands, 30

compliance

 EMC, 59

 safety, 60

connectors

 front panel, 4

 rear panel, 5

control interfaces

 specifications, 26

cooling, 2

D

data error insertion

 specifications, 26

data output specifications

 PPG1600, PPG3000, 18

 PPG3200, 17

data outputs

 output range, 14

data patterns specifications, 19

differential channels, x

documentation, xi

E

EMC compliance, 59

environmental considerations, 3

Environmental considerations, 62

Equipment recycling, 62

eye diagram, 9

F

features, ix

flat panel display

 cleaning, 56

fuse, 2

 replacement, 57

G

general safety summary, v

I

important safety information, v

J

jitter insertion specifications, 21

M

maintenance

 cleaning, 56

 preventive, 56

maximum data rate, x

model codes, 30

O

option FXD verification, 11

options, xi

output range, 14

P

packaging, 57

physical characteristics

 specifications, 26

power requirements, 2

preventive maintenance, 56

product options, xi

R

reference clock specifications, 25

regular commands, 31

repackaging, 57

repair service, 55

RF connectors, 13

S

Safety compliance, 60

service offerings, 55

service safety summary, vii

specifications, 17

 channel skew, 25

 clock inputs, 24

 clock outputs, 20

 control interfaces, 26

 data error insertion, 26

 data patterns, 19

 jitter insertion, 21

 physical characteristics, 26

 PPG1600, PPG3000 data

 outputs, 18

 PPG3200 data outputs, 17

 reference clock, 25

 trigger system, 24

T

termination (PPG3200 with option
 FXD), 11

termination voltage, 15

torque specifications, 13

touch screen, 27

trigger system specifications, 24

U

USB interface, 29

V

ventilation, 2

verification

Instrument setup, 7

W

warranty service, 55