

# DPO2000 and MSO2000 Series Rackmount Kit Instructions

## **Warning**

The servicing instructions are for use by qualified personnel only. To avoid personal injury, do not perform any servicing unless you are qualified to do so. Refer to all safety summaries prior to performing service.

[www.tektronix.com](http://www.tektronix.com)



071-2332-00

**Tektronix**

Copyright © Tektronix. All rights reserved. Licensed software products are owned by Tektronix or its subsidiaries or suppliers, and are protected by national copyright laws and international treaty provisions.

Tektronix products are covered by U.S. and foreign patents, issued and pending. Information in this publication supersedes that in all previously published material. Specifications and price change privileges reserved.

TEKTRONIX and TEK are registered trademarks of Tektronix, Inc.

## **Contacting Tektronix**

Tektronix, Inc.  
14200 SW Karl Braun Drive  
P.O. Box 500  
Beaverton, OR 97077  
USA

For product information, sales, service, and technical support:

- In North America, call 1-800-833-9200.
- Worldwide, visit [www.tektronix.com](http://www.tektronix.com) to find contacts in your area.

---

# Table of Contents

Service Safety Summary.....	ii
Kit Description.....	1
Products.....	1
Kit Parts List.....	1
Clearance Requirements.....	3
Installation Instructions.....	5
Minimum Tool and Equipment List.....	5
Install.....	6
Rackmount the Rack-Adapted Instrument without rack slides.....	9
Rackmount the Rack-Adapted Instrument using rack slides.....	10

## Service Safety Summary

Only qualified personnel should perform service procedures. Read this *Service Safety Summary* and the *General Safety Summary* before performing any service procedures.

**Do Not Service Alone.** Do not perform internal service or adjustments of this product unless another person capable of rendering first aid and resuscitation is present.

**Disconnect Power.** To avoid electric shock, switch off the instrument power, then disconnect the power cord from the mains power.

**Use Care When Servicing With Power On.** Dangerous voltages or currents may exist in this product. Disconnect power, remove battery (if applicable), and disconnect test leads before removing protective panels, soldering, or replacing components.

To avoid electric shock, do not touch exposed connections.

# Kit Description

This introduction describes the rackmount kit for your standard bench-top instrument.

The rackmount kit is a collection of parts that, once installed, configure the instrument for mounting into a standard 19-inch equipment rack.

## Products

<b>DPO2000 Series</b>	All serial numbers
<b>MSO2000 Series</b>	All serial numbers

## Kit Parts List

---

**NOTE.** *The hardware set included in this kit is also used with other kits. Not all of the hardware will be needed.*

---

**Table 1: Kit parts list**

<b>Circuit/figure number</b>	<b>Quantity</b>	<b>Part number</b>	<b>Description</b>
1-1	1 each	407-5315-xx	BRACKET, BOTTOM
-2	1 each	426-2632-xx	FACEPLATE, FRONT BRACKET
-3	1 each	407-5318-xx	BRACKET, LEFT SIDE
-4	1 each	407-5317-xx	BRACKET, RIGHT SIDE
-5	1 each	407-5316-xx	BRACKET, TOP
-6	2 each	367-0450-xx	HANDLE, BOW; CARRYING, 3.75 CTR, 8-32 THD 1.75 H, TG2000, SAFETY CONTROLLED
Not shown	1 each	071-2332-00	INSTRUCTIONS, TECH:RACKMOUNT, ENGLISH; RMD2000 (this document)
Not shown	1 each	016-2006-xx	KIT, HARDWARE RMD2000 — Includes the bow handles (above) and all the following:
Not shown	4 each	210-0833-xx	WASHER, RECESSED; 0.42 ID X 0.112 THK, STL NI PLATED, 0.588 OD
Not shown	4 each	210-1061-xx	WASHER, FLAT; 0.203 ID X 0.625 OD X 0.062, 410 SS, PASSIVATE
Not shown	4 each	210-1546-xx	SCREW, MACHINE, PAN, 8-32 X 1/2 PHIL, SST
Not shown	4 each	210-1547-xx	LOCKWASHER, #8, SPLIT, .040 THICK
Not shown	4 each	210-1548-xx	WASHER, FLAT, 12 mm OD X 6.4 mm ID X 1.6 mm THK, STAINLESS STEEL
Not shown	14 each	211-0507-xx	SCREW, MACHINE; 6-32 X 0.312, PNH, 410 SS PASSIVATED, POZ

Table 1: Kit parts list, (cont.)

Circuit/figure number	Quantity	Part number	Description
Not shown	4 each	211-0538-xx	SCREW, MACHINE; 6-32 X 0.312, FLH, 100 DEG, 410 SS PASSIVATED, POZ
Not shown	4 each	211-1218-xx	M6 X 16MM PHIL OVAL HEAD, 410 SS, PASSIVATE
Not shown	4 each	211-1219-xx	SCREW, M5 X 16MM PHIL OVAL, 410 SS, PASSIVATE
Not shown	4 each	212-0043-xx	SCREW, MACHINE; 8-32 X 0.5, FLH, 100 DEG, 410 SS, POZ
Not shown	4 each	212-0591-xx	SCREW, MACHINE; 10-32 X 0.75, OVH, POZ, STL, NI
Not shown	4 each	213-0199-xx	SCREW, MACHINE; 12-24 X 0.75, OVH, STL NP, POZ

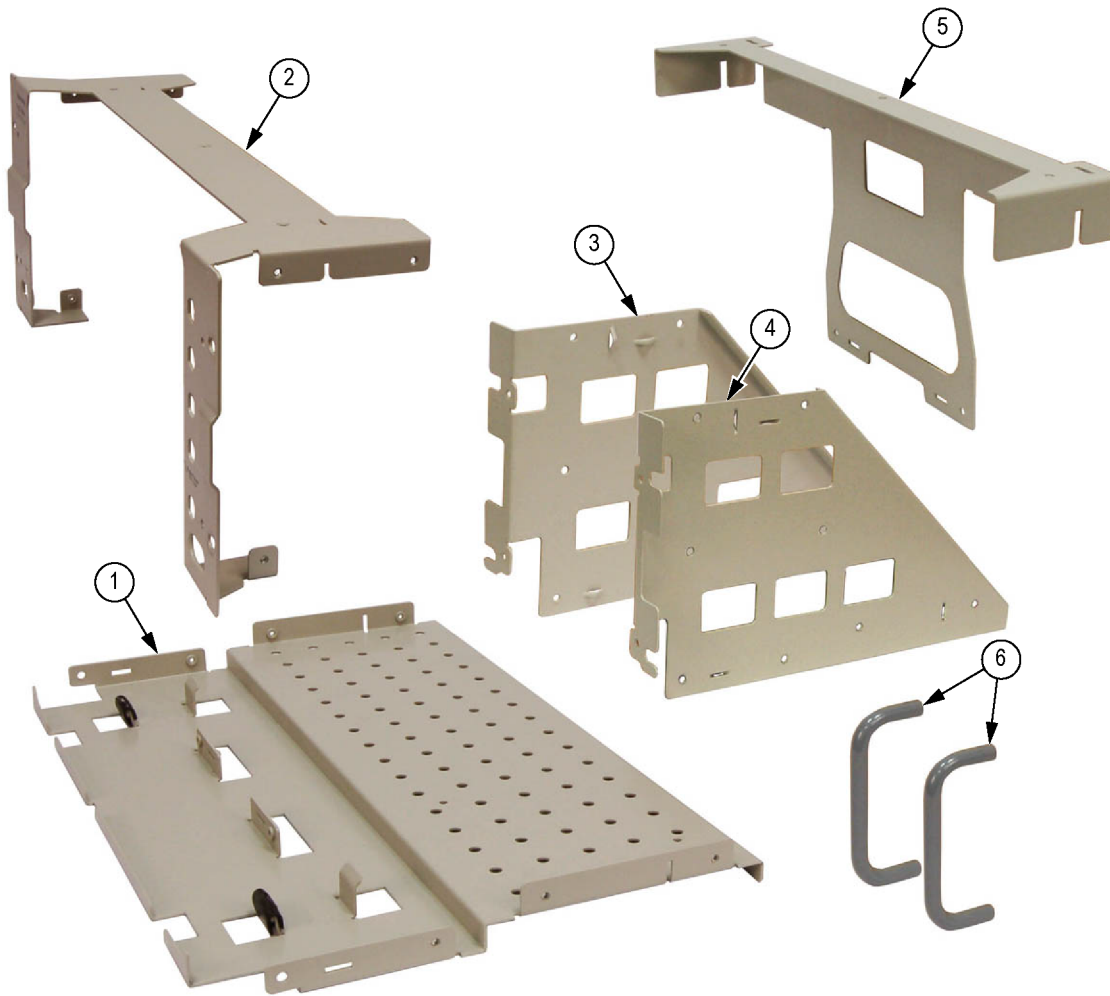

2332-001

Figure 1: Rackmount kit parts

Table 2: Optional accessories (must be ordered separately)

Circuit/figure number	Quantity	Part number	Description
2-1	1 pair	351-1095-00	SLIDE ASSY; PAIR, W/STD HARDWARE KIT AND REAR BRACKET

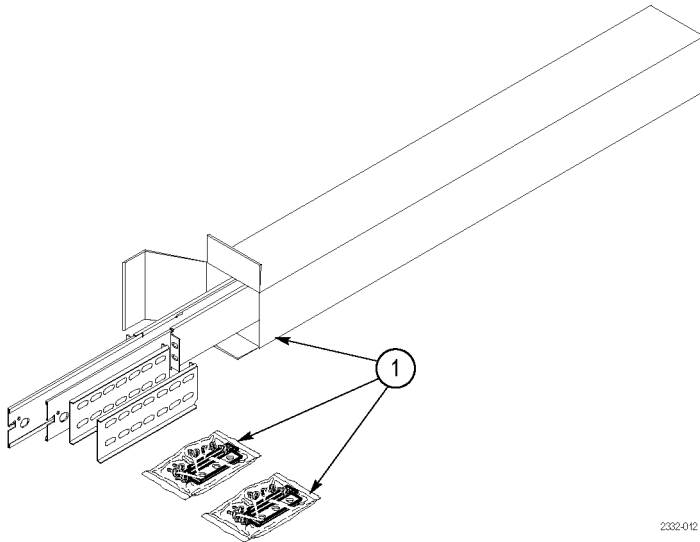

Figure 2: Optional accessories

---

**NOTE.** The rack slides are not part of this kit. They are optional, and must be ordered separately.

---

## Clearance Requirements

The rack in which the rack-adapted instrument is mounted must provide the following clearance requirements:

- A minimum of 177.80 mm (7.00 in) of vertical space
- A minimum width of 450.10 mm (17.72 in) between the left- and right-front rails in the rack
- A minimum depth of 336.55 mm (13.25 in)



---

**CAUTION.** Adhering to these clearance requirements provides the rack-mounted instrument with sufficient clearance for air circulation and accommodation of the power cord and mounting hardware. Failure to provide these clearances can result in overheating and can cause instrument faults or failure.

---

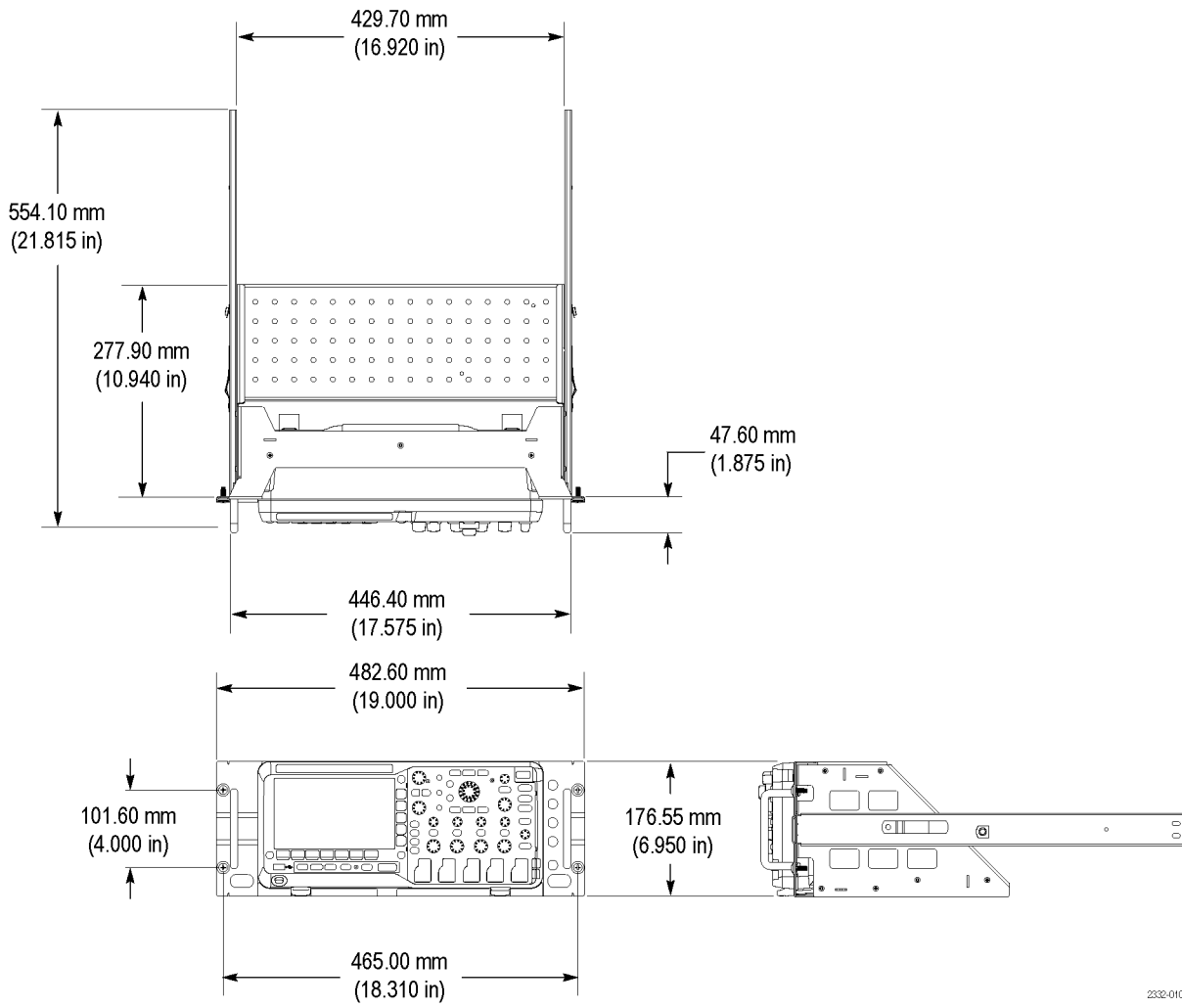

Figure 3: Instrument with rack adapter installed



# Installation Instructions

This section contains the procedures needed to rackmount a DPO2000 or MSO2000 series instrument.

## Minimum Tool and Equipment List

The following tools are required to attach the rack-adapter kit hardware, install cabling hardware, and mount the rack-adapted instrument into a standard equipment cabinet. All tools are standard tools that are readily available.

**Table 3: Tools required for rackmount installation**

Name	Description
Screwdriver handle (magnetic)	Accepts 1/4 inch hexagonal head driver tips
No. 2 Pozidriv or Phillips tip	Pozidriv or-Phillips driver tip for number 2 size screw heads
Straight tip	Straight screwdriver tip for slotted screw heads
1/4 inch wrench	Wrench or nut driver can be used to install slides
Torque driver	6.5 in long shaft; accepts 1/4 inch hexagonal head driver tips

These instructions are for qualified service personnel who are familiar with servicing the product. If you need further details for disassembling or reassembling the product, refer to the appropriate product manual. Contact your nearest Tektronix Service Center or Tektronix Factory Service for installation assistance.



**WARNING.** *To prevent the rackmounted instrument from tipping forward onto the operator, install the instrument so that the operator will be able to access all of its rear-panel connectors without pushing down on the instrument.*

*Verify that the rack does not become unstable with the instrument fully extended. Do not leave the instrument extended when finished accessing the rear panel.*

## Install

*Equipment Required:* Torque driver with #2 Pozidriv tip.

This section describes mounting the rackmount adapter parts to the instrument.

1. Install the left and right side brackets onto the bottom bracket using three of the 6-32 x 0.312 inch pan head Pozidriv screws on each side. Tighten these screws to 8 in-lb.

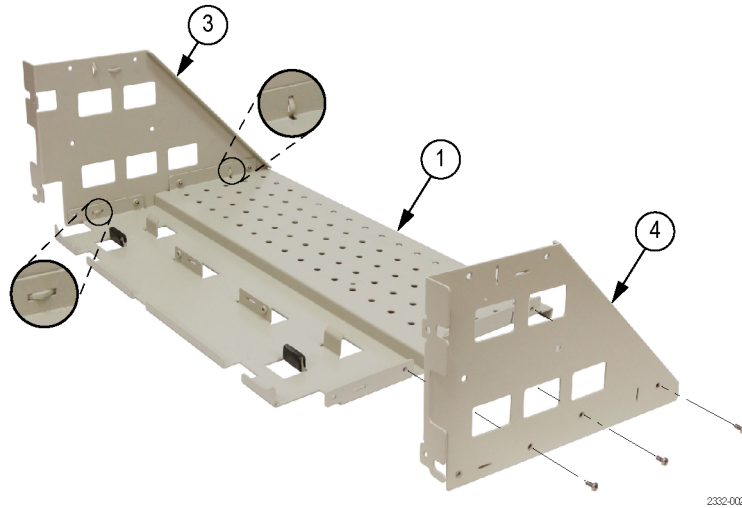

2. Place the oscilloscope into the rackmount frame as shown. Position the oscilloscope's rear feet in the brackets. The front of the oscilloscope will extend slightly beyond the front of the rackmount frame.

If your application requires that the digital probe be routed to the interior of the rack, place the probe cable(s) in the slot provided before positioning the oscilloscope.



- Place the oscilloscope handle in the straight-back position and install the top bracket, aligning the cutouts in the bracket as shown. You will have to pull the bottom of the bracket out a little, to clear the rear panel connectors, as you slide the bracket into position.

Use two of the 6-32 x 0.312 inch pan head Pozidriv screws to attach the top bracket to the oscilloscope. Tighten these screws to 8 in-lb.

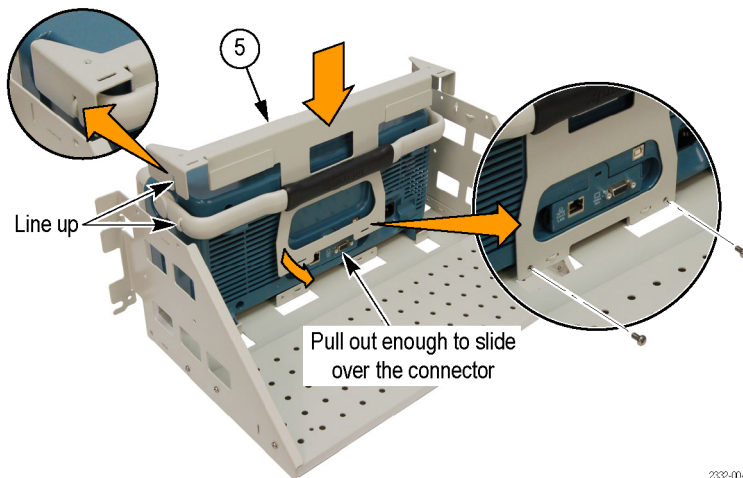

2232-004

For your convenience there are five holes in the right side of the front panel. These are designed to accommodate BNC double female bulkhead jacks, also known as bulkhead adapters. If you need them in your installation, install the adapters now. It is also recommended that you attach the interior cables to the adapters before installing the front panel bracket, in the next step.

**NOTE.** The BNC double female jacks are not included as part of this rackmount kit; they must be purchased separately.

- Align the guides in the front panel bracket and the sides, as shown, and then swing the bottom of the front panel bracket into position.

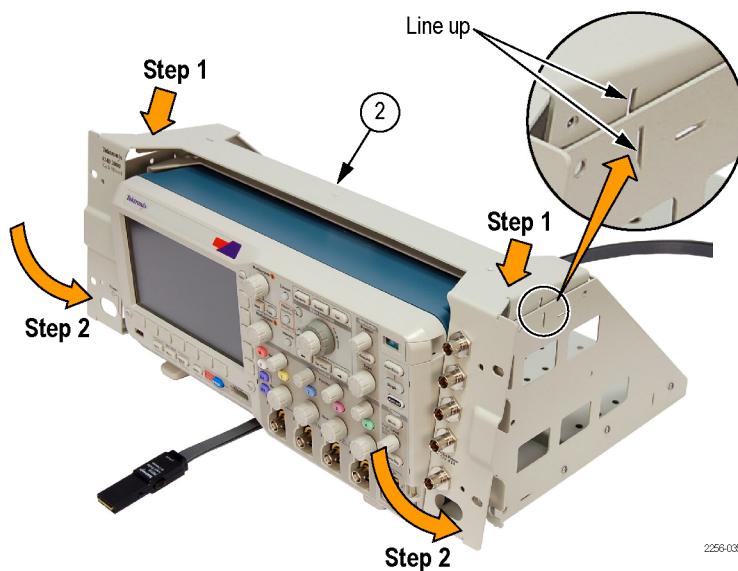

2256-005

5. Attach the front panel bracket to the sides with three of the 6-32 x 0.312 inch pan head Pozidriv screws on each side. Tighten these screws to 8 in-lb.
6. Attach the front panel bracket to the top bracket with three of the 6-32 X 0.312 flat head Pozidriv screws. Tighten these screws to 8 in-lb.

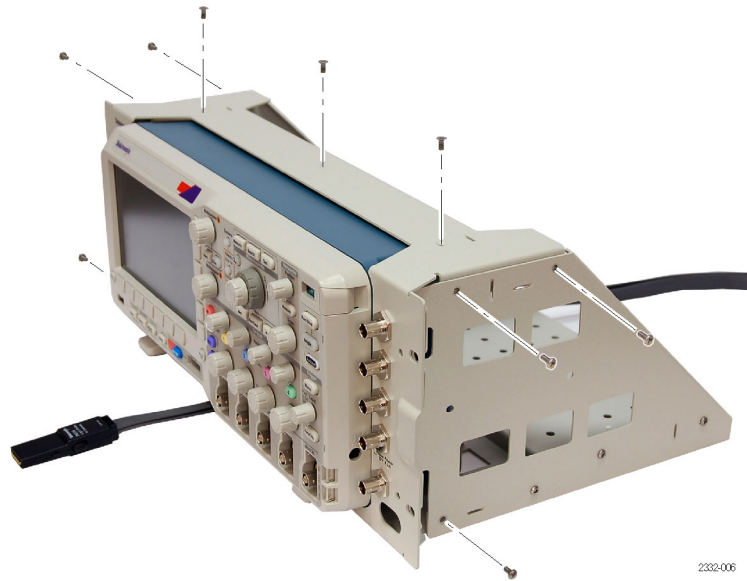

2332-006

7. Attach the handles, using two of the 8-32 x 1/2 panhead screws and split lockwashers in each handle. Torque these screws to 16 in-lb.

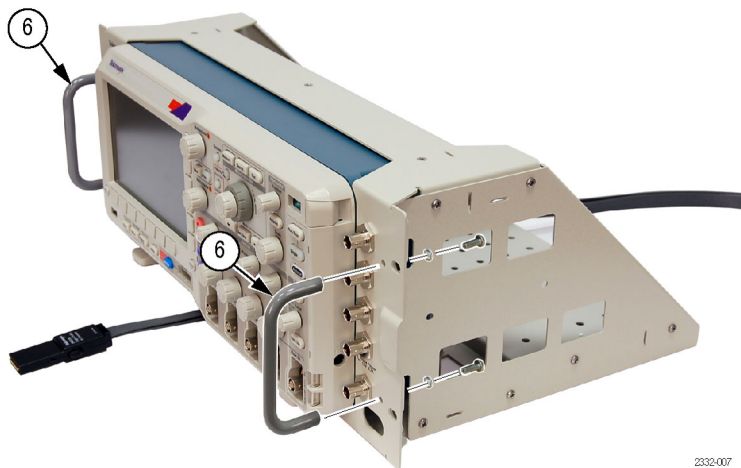

2332-007

**NOTE.** The bottom bracket has holes to facilitate mounting optional accessories. Optional accessories may be mounted with screws, or you can use nylon straps to secure them. These screws and nylon straps are not included in the kit.

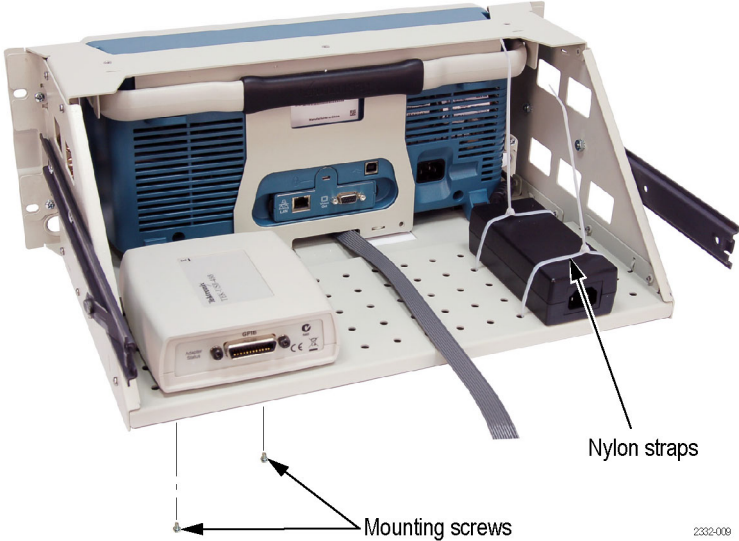

### Rackmount the Rack-Adapted Instrument without rack slides

If you did not order the optional rackmount slides, you may install the rack-adapted instrument into an equipment rack by following this procedure:

**WARNING.** To prevent the instrument from tipping or falling onto the installers, this procedure should be performed by two or more people.

#### Install Instrument into the Rack

Equipment Required: One screwdriver handle and one number two Pozidriv tip.  
Procedure:

- 1. Select the appropriate screws for your equipment rack from the kit; 10-32, 12-24, M5, or M6. Assemble them with the recessed and flat washers as shown:

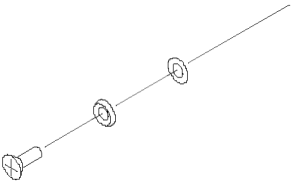

Screw type	Use this flat washer
10-32	0.625 in. OD
12-32	12 mm OD
M5	0.625 in. OD
M6	12 mm OD

2332-018

2. Standard equipment racks utilize one of two mounting hole spacing methods. Both methods use mounting holes spaced 0.5 inch apart, separated by a 1.25 inch gap. One method (A) places an additional mounting hole in the middle of the 1.25 inch gap (at 0.625, or 5/8, inch); the other method (B) does not.
3. Select two 0.5 inch-spaced holes in the front rail. Verify that there are clearances of 1.5 inch above the upper mounting hole and 5.50 inch below the lower mounting hole.
4. Slide the oscilloscope into the equipment rack so that the pin extending back from the left side, just below the upper mounting hole, goes into the lower of the 0.5 inch-spaced holes in the front rail. This pin is a locating guide, and also an aid to holding the oscilloscope in place while securing the oscilloscope to the instrument rack.
5. Use the screws and washers from step 1 to secure the oscilloscope to the instrument rack.

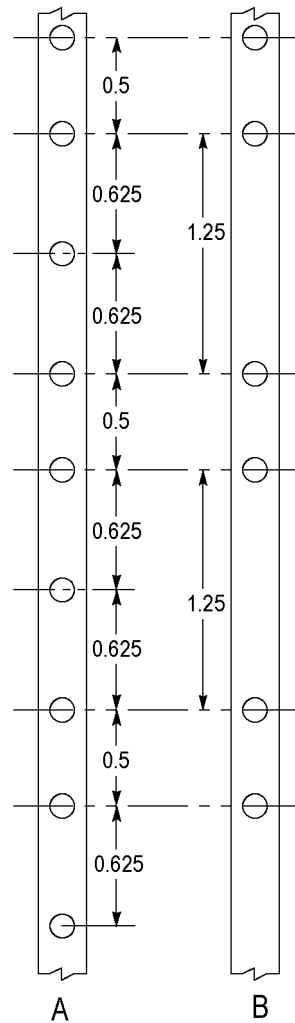

2332-013

## Rackmount the Rack-Adapted Instrument using rack slides

If you ordered the optional rackmount slides, this procedure assembles and installs the slide-out tracks in the equipment rack, and then installs the rack-adapted instrument in the rack.

The slide-out tracks permit the rack-adapted instrument to be extended out of the rack for rear-panel and connector maintenance without removing the instrument from the rack.



**WARNING.** To prevent the rackmounted instrument from tipping forward onto the operator, install the instrument so that the operator will be able to access all of its rear devices without pushing down on the instrument.

Verify that the rack does not become unstable with the instrument fully extended. Do not leave the instrument extended when finished accessing the rear panel.

### Install Track Assembly and Instrument into the Rack

Equipment Required: One screwdriver handle, one number two Pozidriv tip, one straight slot tip, one 1/4 inch wrench, and one torque driver.

**NOTE.** The rack hardware kit contains hardware for mounting the instrument in several configurations. Not all of the hardware in the kit will be needed.

#### Attach the front (chassis) left and right tracks to the rack adapter:

1. Remove the front (chassis) section of each of the two tracks.

Remove this section from each track.

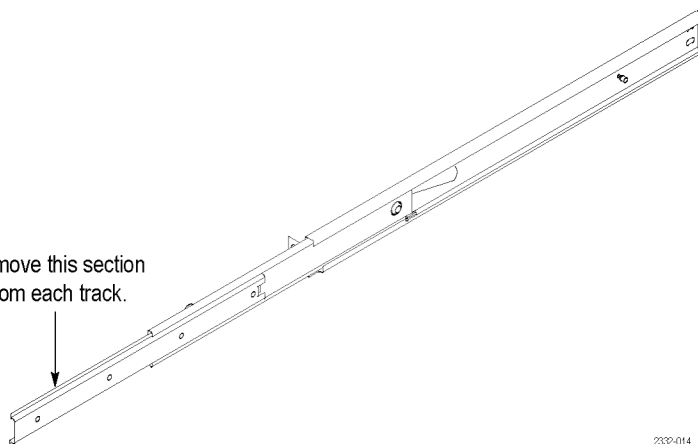

2332-014

2. Install the front left- and right-side track sections on the instrument using four of the 10-32 x 3/8 inch slotted screws and the nuts with captured lockwashers. Tighten to 28 in-lb.

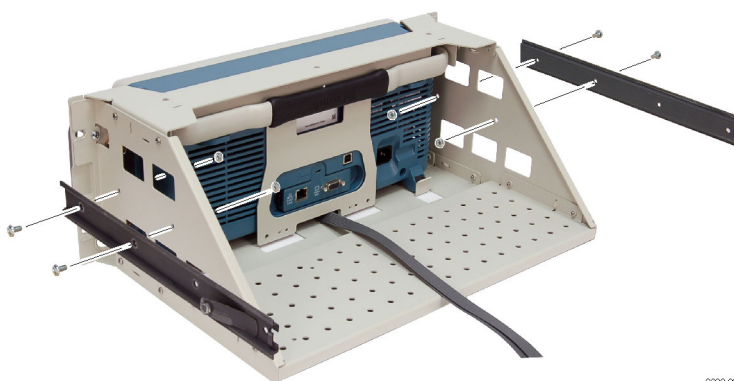

2332-008



**WARNING.** To ensure that the rackmount track locks, make sure the track button latches are oriented correctly: the right-side latch is located toward the bottom of the rackmount panel and the left-side latch is located toward the top of the rackmount panel.

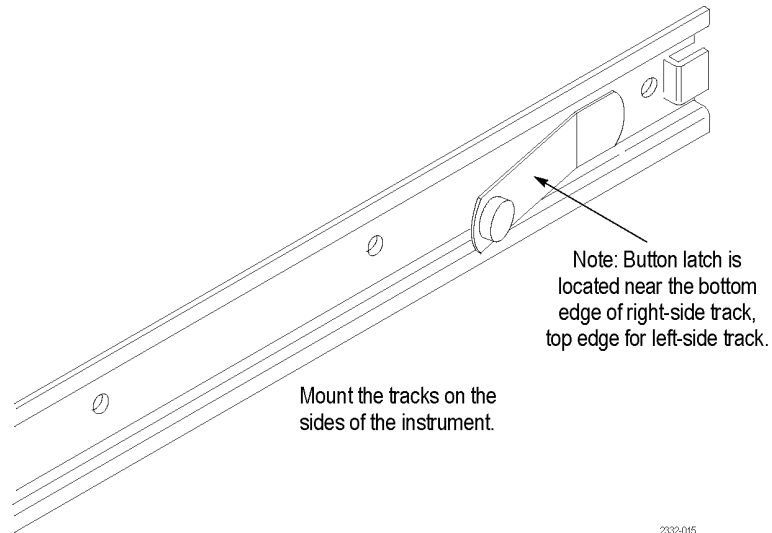

**Assemble the slide-out track:**

3. Measure the distance between the front and rear rail of the equipment rack.
4. Align the rear bracket to the right slide-out track as shown. Note that the rear bracket has multiple pairs of mount-through holes. When aligning the bracket and track, be sure to select a pair of holes that mount the rear bracket so that the flange-to-flange distance matches the distance between the front rail and rear rail measured in step 3.
5. Using a screwdriver with a number two Pozidriv tip, secure the rear bracket to the right slide-out track using two screws (10-32) and a bar nut as illustrated. Leave the screws loose so that the overall length of the slide-out track assembly can be adjusted when installing it in the rack.
6. Step-Repeat steps 4 and 5 to assemble the left slide-out track assembly.

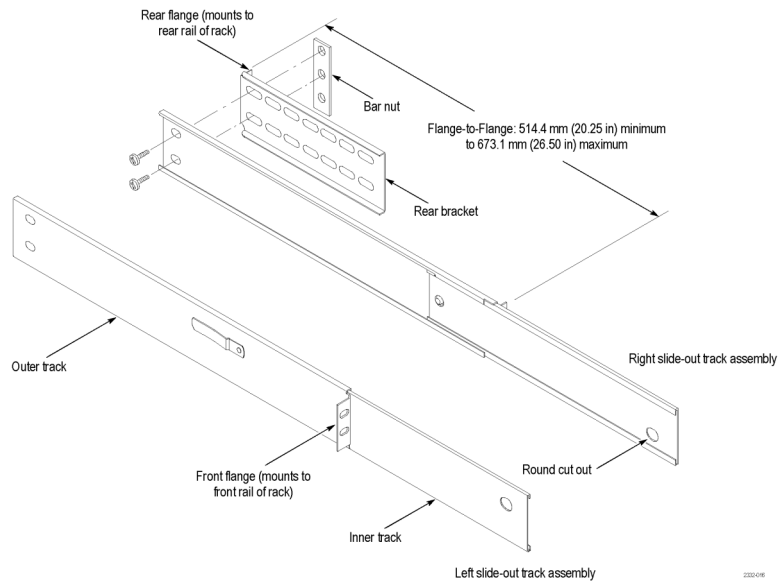



**Mount the slide-out track assemblies:**

- 7. *Select the mounting position in the rack:* Select two 0.5 inch-spaced holes in the front rail, and verify that there is a 3.25 inch clearance above and below those mounting holes.

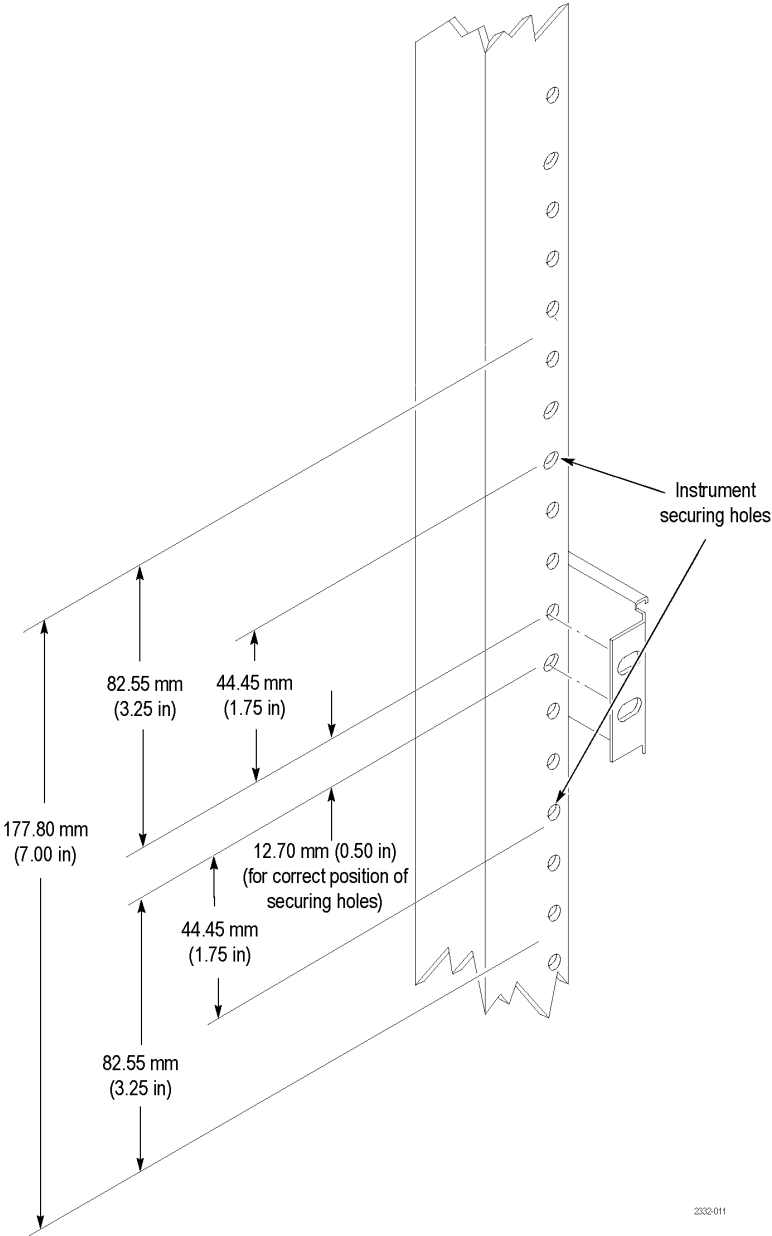

232-011

**8.** Select the mounting method according to the rack type:

- To mount the slide-out tracks with their front and rear flanges outside of the front and rear rails, use the mounting method A. (See Figure 4.) Add a bar nut to the installation only if the rails have untapped holes.
- To mount with front and rear flanges inside of rails, use the mounting method B. (See Figure 4.) This mounting method assumes untapped holes.

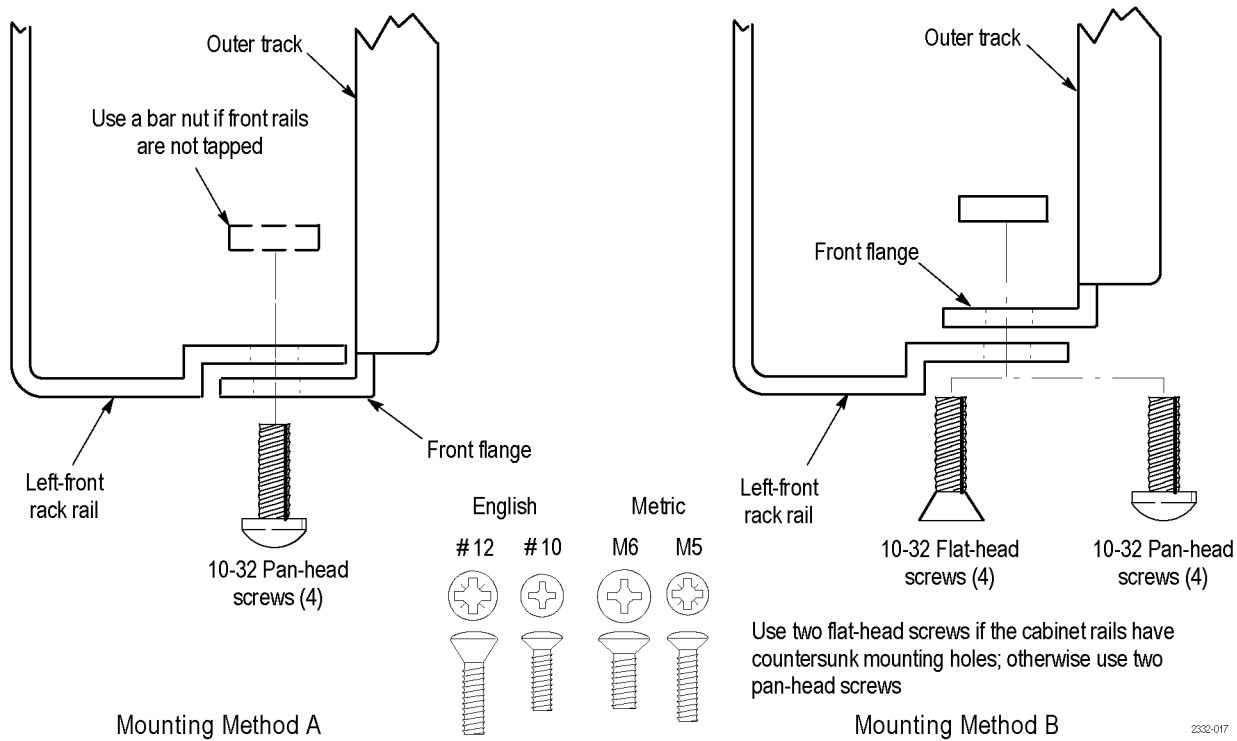

**Figure 4: Installation of slide-out track assemblies in rack (top view)**

- 9.** Install in rack: Using the method and hardware determined in step 8, secure the right slide-out track assembly to its front and rear rails. The screws should be fully, but lightly, seated so mounting can be adjusted later.
- 10.** Fix the length of the slide-out track assembly: Tighten the screws left loose in step 5 to 28 inch-lb, to fix the front to rear flange spacing of the slide-out track assembly.
- 11.** Mount the left slide-out track assembly: Repeat steps 9 and 10 to mount the left slide-out track assembly.

## Mount the instrument in the rack:



**WARNING.** *To prevent the instrument from tipping or falling onto the installers, two or more people should install this instrument into the rack cabinet.*

*After completing the installation procedure, the installers should verify that the instrument and rack cabinet will not tip forward while the instrument is in the extended position.*

1. Install the instrument:
  - a. Working from the front of the rack, slide the inner track of each slide-out track assembly until it extends out the front of the rack. Continue to slide them out until they lock.
  - b. Insert the left and right tracks that extend from the rear of the instrument into the ends of the tracks just extended. Make sure the tracks mounted on the instrument slip inside the inner tracks extended earlier.
  - c. Slide the instrument backwards until it stops.
  - d. Push to release the button latches, located on the outside of each track, and continue to slide the instrument all the way into the cabinet.
2. Level the rackmounted instrument:
  - a. Tighten the four screws that were left loose at the rear of the rack when you did step 5, and then pull the instrument part way out of the rack.
  - b. Be sure that the four screws that were left loose at the front of the rack are loose enough to allow the slide-out track assemblies to seek their normal positions.
  - c. Retighten the four screws and push the instrument all the way into the rack. If the tracks do not slide smoothly, readjust the level using the method just detailed.
  - d. When leveling is completed, tighten the 10-32 screws using 28 inch-lb of torque.

**Finishing the Installation** It is recommended that you secure the instrument to the rack.



---

**WARNING.** *To prevent the rackmounted instrument from sliding forward and causing personal injury or instrument damage, always secure the instrument to the rack if the rack is moved (for example, if the rack is repositioned or relocated to another room).*

---

3. Secure the instrument to the rack:
  - a. Select four of the appropriate screws for your equipment rack from the kit; 10-32, 12-24, M5, or M6.
  - b. Secure the instrument in the rack using the screws selected, with the recessed washers and flat washers.

**End of Document**