



**TCA75
Impedance Conversion Adapter
Instructions**

www.tek.com



071-1192-03

Copyright © Tektronix. All rights reserved. Licensed software products are owned by Tektronix or its subsidiaries or suppliers, and are protected by national copyright laws and international treaty provisions.

Tektronix products are covered by U.S. and foreign patents, issued and pending. Information in this publication supersedes that in all previously published material. Specifications and price change privileges reserved.

TEKTRONIX and TEK are registered trademarks of Tektronix, Inc.

Contacting Tektronix

Tektronix, Inc.
14150 SW Karl Braun Drive
P.O. Box 500
Beaverton, OR 97077
USA

For product information, sales, service, and technical support:

- In North America, call 1-800-833-9200.
- Worldwide, visit www.tek.com to find contacts in your area.

Warranty

Tektronix warrants that this product will be free from defects in materials and workmanship for a period of one (1) year from the date of shipment. If any such product proves defective during this warranty period, Tektronix, at its option, either will repair the defective product without charge for parts and labor, or will provide a replacement in exchange for the defective product. Parts, modules and replacement products used by Tektronix for warranty work may be new or reconditioned to like new performance. All replaced parts, modules and products become the property of Tektronix.

In order to obtain service under this warranty, Customer must notify Tektronix of the defect before the expiration of the warranty period and make suitable arrangements for the performance of service. Customer shall be responsible for packaging and shipping the defective product to the service center designated by Tektronix, with shipping charges prepaid. Tektronix shall pay for the return of the product to Customer if the shipment is to a location within the country in which the Tektronix service center is located. Customer shall be responsible for paying all shipping charges, duties, taxes, and any other charges for products returned to any other locations.

This warranty shall not apply to any defect, failure or damage caused by improper use or improper or inadequate maintenance and care. Tektronix shall not be obligated to furnish service under this warranty a) to repair damage resulting from attempts by personnel other than Tektronix representatives to install, repair or service the product; b) to repair damage resulting from improper use or connection to incompatible equipment; c) to repair any damage or malfunction caused by the use of non-Tektronix supplies; or d) to service a product that has been modified or integrated with other products when the effect of such modification or integration increases the time or difficulty of servicing the product.

THIS WARRANTY IS GIVEN BY TEKTRONIX WITH RESPECT TO THE PRODUCT IN LIEU OF ANY OTHER WARRANTIES, EXPRESS OR IMPLIED. TEKTRONIX AND ITS VENDORS DISCLAIM ANY IMPLIED WARRANTIES OF MERCHANTABILITY OR FITNESS FOR A PARTICULAR PURPOSE. TEKTRONIX' RESPONSIBILITY TO REPAIR OR REPLACE DEFECTIVE PRODUCTS IS THE SOLE AND EXCLUSIVE REMEDY PROVIDED TO THE CUSTOMER FOR BREACH OF THIS WARRANTY. TEKTRONIX AND ITS VENDORS WILL NOT BE LIABLE FOR ANY INDIRECT, SPECIAL, INCIDENTAL, OR CONSEQUENTIAL DAMAGES IRRESPECTIVE OF WHETHER TEKTRONIX OR THE VENDOR HAS ADVANCE NOTICE OF THE POSSIBILITY OF SUCH DAMAGES.

[W2 – 15AUG04]

Table of Contents

Important safety information	ii
General safety summary	ii
Service safety summary	ii
Terms in this manual	iii
Symbols and terms on the product	iii
Environmental considerations	iv
Product end-of-life handling	iv
TCA75 impedance conversion adapter	1
Connecting the TCA75 adapter to the host instrument	2
Input signal connections	3
Specifications	3
Performance verification	7
Test equipment	7
Output impedance	8
Input impedance	9
Attenuation accuracy	10
Probe calibration routine	12
TCA75 test record	13

Important safety information

This manual contains information and warnings that must be followed by the user for safe operation and to keep the product in a safe condition.

To safely perform service on this product, additional information is provided at the end of this section. (See page ii, *Service safety summary*.)

General safety summary

Use the product only as specified. Review the following safety precautions to avoid injury and prevent damage to this product or any products connected to it. Carefully read all instructions. Retain these instructions for future reference.

To avoid fire or personal injury

Observe all terminal ratings. To avoid fire or shock hazard, observe all ratings and markings on the product. Consult the product manual for further ratings information before making connections to the product. Do not exceed the voltage rating.

Do not apply a potential to any terminal, including the common terminal, that exceeds the maximum rating of that terminal.

Do not operate without covers. Do not operate this product with covers or panels removed, or with the case open. Hazardous voltage exposure is possible.

Do not operate in wet/damp conditions. Be aware that condensation may occur if a unit is moved from a cold to a warm environment.

Do not operate in an explosive atmosphere.

Keep product surfaces clean and dry. Remove the input signals before you clean the product.

Service safety summary

The *Service safety summary* section contains additional information required to safely perform service on the product. Only qualified personnel should perform service procedures. Read this *Service safety summary* and the *General safety summary* before performing any service procedures.

Do not service alone. Do not perform internal service or adjustments of this product unless another person capable of rendering first aid and resuscitation is present.

Terms in this manual

These terms may appear in this manual:



WARNING. *Warning statements identify conditions or practices that could result in injury or loss of life.*



CAUTION. *Caution statements identify conditions or practices that could result in damage to this product or other property.*

Symbols and terms on the product

These terms may appear on the product:

- DANGER indicates an injury hazard immediately accessible as you read the marking.
- WARNING indicates an injury hazard not immediately accessible as you read the marking.
- CAUTION indicates a hazard to property including the product.



When this symbol is marked on the product, be sure to consult the manual to find out the nature of the potential hazards and any actions which have to be taken to avoid them. (This symbol may also be used to refer the user to ratings in the manual.)

The following symbol(s) may appear on the product:



CAUTION
Refer to Manual

Environmental considerations

This section provides information about the environmental impact of the product.

Product end-of-life handling

Observe the following guidelines when recycling an instrument or component:

Equipment recycling. Production of this equipment required the extraction and use of natural resources. The equipment may contain substances that could be harmful to the environment or human health if improperly handled at the product's end of life. In order to avoid release of such substances into the environment and to reduce the use of natural resources, we encourage you to recycle this product in an appropriate system that will ensure that most of the materials are reused or recycled appropriately.



This symbol indicates that this product complies with the applicable European Union requirements according to Directives 2012/19/EU and 2006/66/EC on waste electrical and electronic equipment (WEEE) and batteries. For information about recycling options, check the Tektronix Web site (www.tek.com/productrecycling).

TCA75 impedance conversion adapter

The TCA75 is a 75 to 50 Ω impedance conversion adapter with a very low VSWR (voltage standing-wave ratio) to 23 GHz. (See Figure 1.) The adapter allows you to connect video and communication signals from a 75 Ω source to the 50 Ω input of oscilloscopes equipped with the TekConnect interface, while minimizing aberrations and reflections. The TCA75 adapter fully complies with ANSI T1.102 and ITU-T G.703.

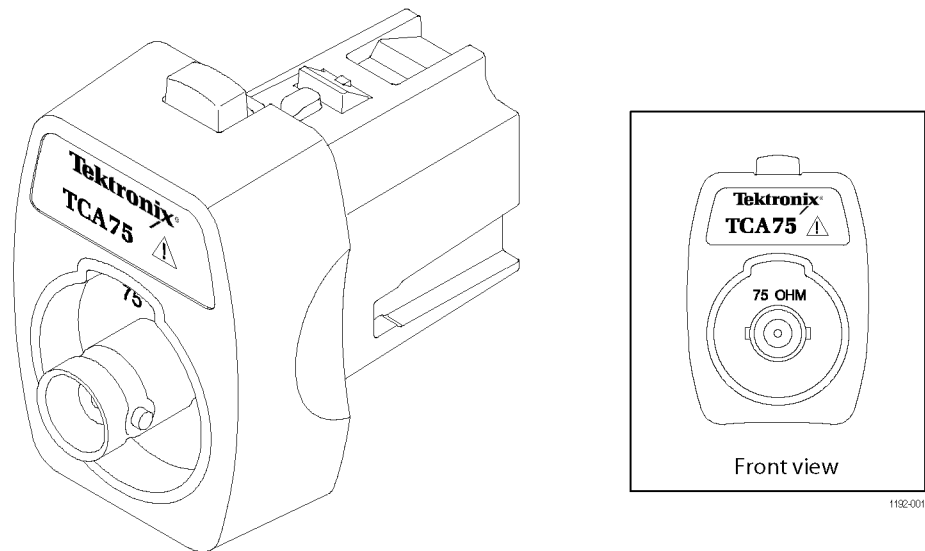

CAUTION. *The TCA75 adapter contains components that are sensitive to electrostatic discharge (ESD). To avoid electrostatic damage, observe ESD precautions when handling the adapter.*

Connecting the TCA75 adapter to the host instrument

The output of the TCA75 adapter connects directly to the TekConnect interface on Tektronix MSO/DPO70000 series oscilloscopes. (See Figure 2.) The TCA75 is not compatible with oscilloscopes that do not have the TekConnect interface. The shell of the input on all oscilloscopes must connect to earth ground.

The TCA75 adapter connects to the host instrument through the TekConnect interface. The TekConnect interface features a spring-loaded latch that indicates a reliable connection has been made to the TekConnect host instrument. Slide the TCA75 adapter into the TekConnect receptacle on the host instrument. The unit snaps into the host instrument when fully engaged.

NOTE. After connecting the adapter to the oscilloscope, run the Probe Calibration Routine to ensure accurate measurements.

To release the TCA75 adapter from the host instrument, grasp the adapter, depress the latch button, and pull it out of the TekConnect receptacle.

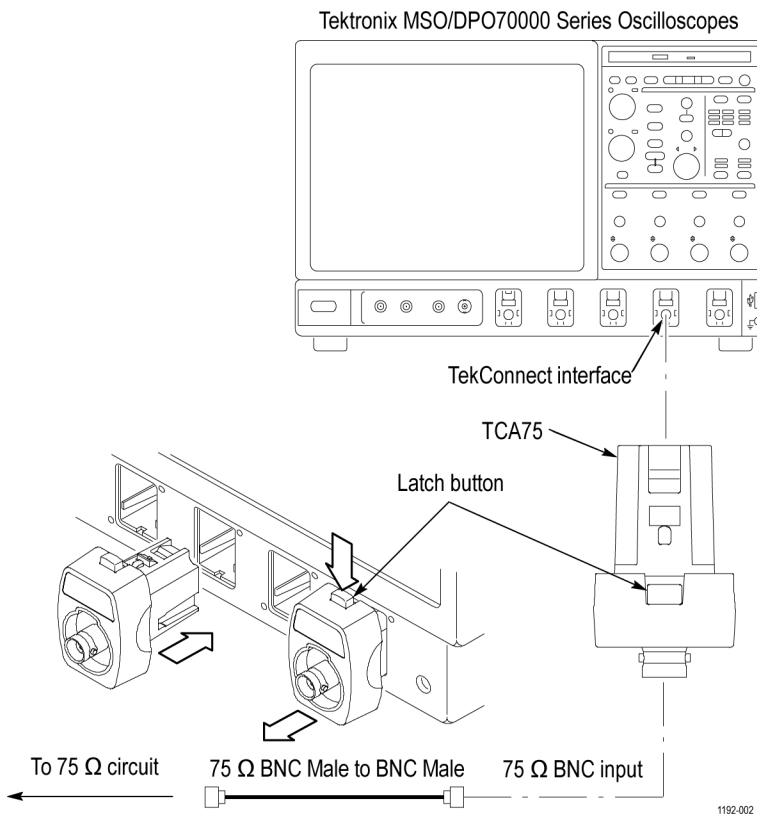

Figure 2: Connecting the adapter to oscilloscopes with the TekConnect interface

Input signal connections

The 75 Ω female BNC input of the TCA75 adapter accepts a 75 Ω male BNC connector. The signal input cable (source) must be 75 Ω .

NOTE. Performance is dependent on the quality of the BNC connectors that you use and the integrity of the connections in your test setup. (See page 6, Connection quality.)

Specifications

This section contains the specifications and compliances for the TCA75 Impedance Adapter. All specifications are guaranteed unless noted as typical. Typical specifications are provided for your convenience but are not guaranteed. Specifications that are marked with the ✓ symbol are checked in the Performance Verification. (See page 7, Performance verification.)

Table 1: Specifications

Specification/compliance	Description
Bandwidth (typical)	23 GHz
Rise time, typical	<18 ps (calculated from the formula $0.4/\text{bandwidth} = \text{rise time}$)
Input VSWR (return loss), typical	$\leq 1.1:1$ (≤ -26 dB) to 4 GHz, $\leq 1.3:1$ (≤ -18 dB) 4 to 8 GHz (See Figure 4 on page 5.)
Return loss	
25 dB	DC to 5 GHz
15 dB	5 to 10 GHz
8 dB	10 to 20 GHz
5 dB	20 to 23 GHz
✓ Input impedance	75 Ω $\pm 1.5\%$ at DC and 25 °C (derate at a linear rate to $\pm 2\%$ @ 0 and 50 °C)
✓ Output impedance	50 Ω $\pm 1.5\%$ at DC and 25 °C (derate at a linear rate to $\pm 2\%$ @ 0 and 50 °C)
✓ Attenuation accuracy @ DC	2.46X $\pm 1.5\%$ at DC (-6 dB power)
Attenuation (power), typical	-6.05 dB ± 0.14 dB, DC to 2 GHz -6.05 dB ± 0.24 dB, 2 GHz to 8 GHz
Attenuation (voltage), typical (dBv = dBpwr + 10log 50/75)	-7.81 dB ± 0.09 dB @DC -7.81 dB ± 0.14 dB, DC to 2 GHz -7.81 dB ± 0.24 dB, 2 GHz to 8 GHz
Rated input voltage (Power)	
Average power, DC or AC	≤ 12 VDC or ≤ 12 VRMS (2 W maximum @25 °C) (derate at a linear rate to 1.625 W @50 °C)
Peak power, AC (See Caution 1)	500 W (Duty cycle of 4% and maximum pulse width of 10 microseconds.)
Gain Drift	0.0006 dB /dB/ °C, +/-25 °C from ambient
DC Linearity	DC: $\pm 0.5\%$ Vin to +12 VDC
Propagation Delay	188 ps ± 10 ps

Table 1: Specifications (cont.)

Specification/compliance	Description	
Temperature	Operating	0 °C to +50 °C (+32 °F to +122 °F)
	Nonoperating	-55 °C to +75 °C (-67 °F to +167 °F)
Humidity	Operating	30 °C to +50 °C (+86 °F to +122 °F), 90 to 95% RH
	Nonoperating	30 °C to +60 °C (+86 °F to +140 °F), 90 to 95% RH
Dimensions	L x W x H: 50.8 cm x 30.5 cm x 45.7 cm (2.0 in. x 1.2 in. x 1.8 in.) Weight (includes packaging): 141.7 gm. (5 oz.)	
Pollution Degree	Pollution Degree 2 (as defined in IEC 61010-1). Note: Rated for indoor use only.	

¹ CAUTION: To prevent damage to the oscilloscope input, do not exceed the oscilloscope input voltage ratings. Refer to the oscilloscope manual before connecting to the circuit under test. Exceeding the scope input voltage ratings may damage the oscilloscope.

NOTE. If the ambient temperature changes by 5 °C or more, run the Probe Calibration Routine to maintain the highest accuracy measurements. (See page 12, Probe calibration routine.)

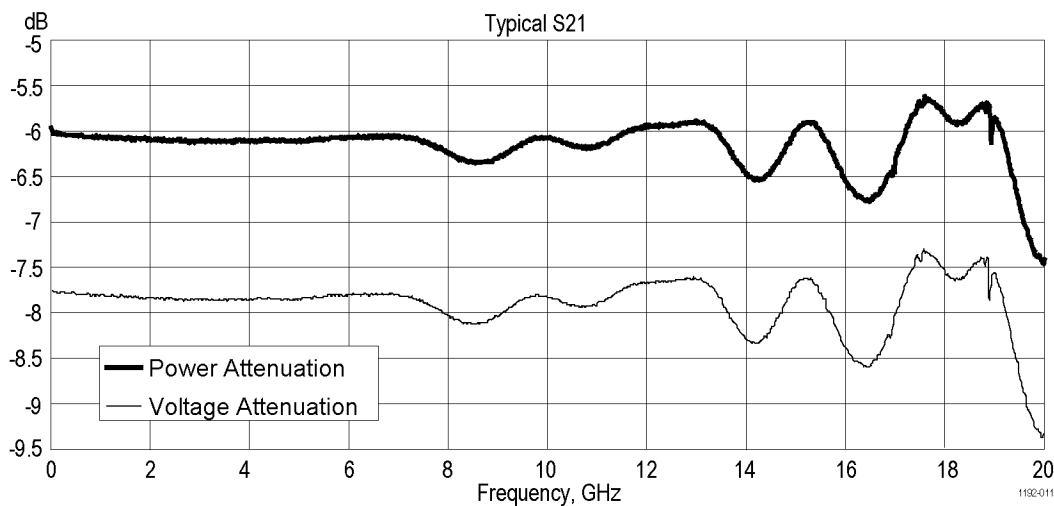

Figure 3: Typical frequency response

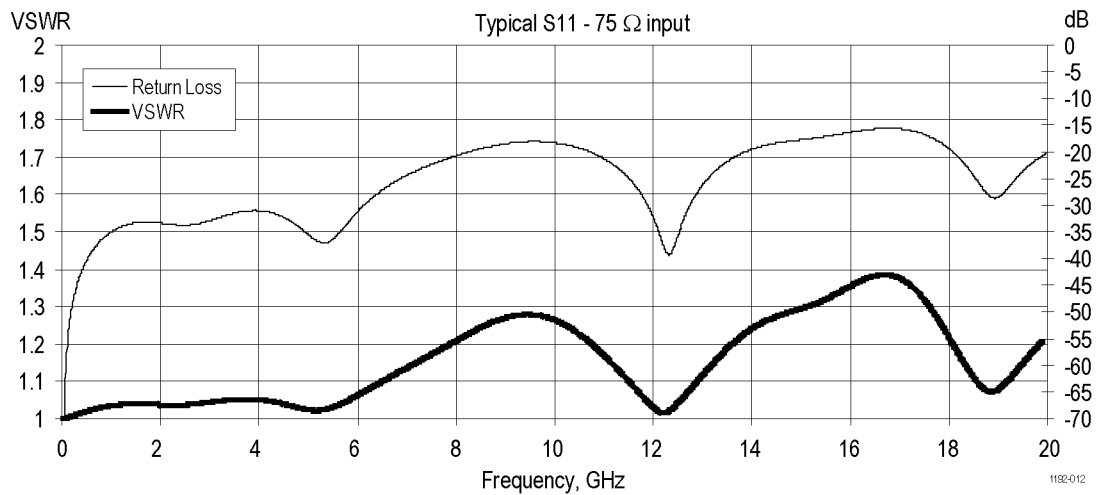

Figure 4: Typical VSWR and return loss

Connection quality

NOTE. To obtain optimum performance when using BNC systems, always use the highest-quality connectors and cables available. Always dress the cables so that they egress straight out from the connections; do not bend the cables near the cable ends. Significant performance variations can occur when you use low-quality components and/or you do not properly connect, seat, and route the BNC connections.

The graph below shows the frequency response of two TCA75 adapters connected back-to-back using a high quality BNC male-to-male adapter and a low quality BNC male-to-male adapter. (See Figure 5.)

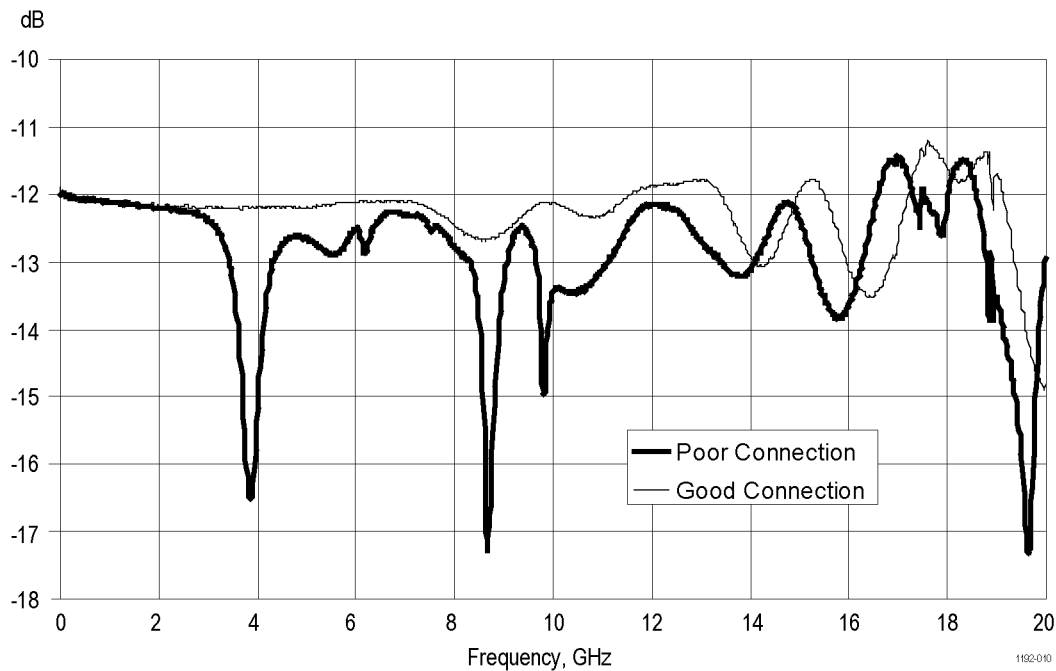

Figure 5: Comparison of connection quality

Performance verification

Use the following procedures to verify the warranted specifications of the TCA75 adapter. Before you begin these procedures, photocopy the test record and use it to record the performance test results for your TCA75 adapter. (See page 13, *TCA75 test record*.) The recommended verification interval is one year.

These procedures are for use by qualified service personnel only, and test the following specifications:

- Output impedance
- Input impedance
- Attenuation accuracy

Warm up the test equipment for at least 20 minutes prior to performing these tests.

Test equipment

The equipment and the minimum specifications required are listed in the table below. An example or part number of the equipment is also provided. (See Table 2.)

Table 2: Test equipment

Description	Minimum requirements	Example product
Power supply	1 VDC out across 75 Ω with <0.5 mV resolution	Fluke 9500B
Digital multimeter (2)	5 1/2 digit with sense, 4 wire, 50 Ω and 75 Ω \pm 0.1%, DCV: 1 V and 200 mV \pm 0.1%	Keithley 2000 or Fluke 884X
SMA to BMA adapter	Male SMA-to-female BMA	Tyco 1059758-1
BNC banana adapter (3)	BNC female-to-dual banana plug	Tektronix part number 103-0090-00
50 Ω BNC cable (2)	BNC male-to-male, 24 inches	Tektronix part number 012-1342-00
50 Ω BNC T adapter	2 female-to-1 male BNC	Tektronix part number 103-0030-00
50 Ω termination	50 Ω \pm 0.1%, 2W, SMA	Tektronix part number 015-1022-01
50 Ω termination	50 Ω , 2W, BNC	Tektronix part number 011-0049-02
50 Ω adapter	SMA barrel	Tektronix part number 015-1012-00
50 Ω adapter	SMA-to-BNC	Tektronix part number 015-1018-00
75 Ω BNC cable (2)	BNC male-to-male, 24 inches	Tektronix part number 012-1339-00
75 Ω BNC T adapter	2 female-to-1 male	Pasternack PE9365
75 Ω termination	75 Ω \pm 0.025%, 2 VRMS, BNC	Tektronix part number 011-0102-03

Output impedance

This test checks the 50 Ω output impedance (of the TekConnect interface circuit) of the adapter.

1. Set the multimeter to 4-wire resistance and the 100 Ω range
2. Connect the TCA75 adapter as shown. (See Figure 6.)

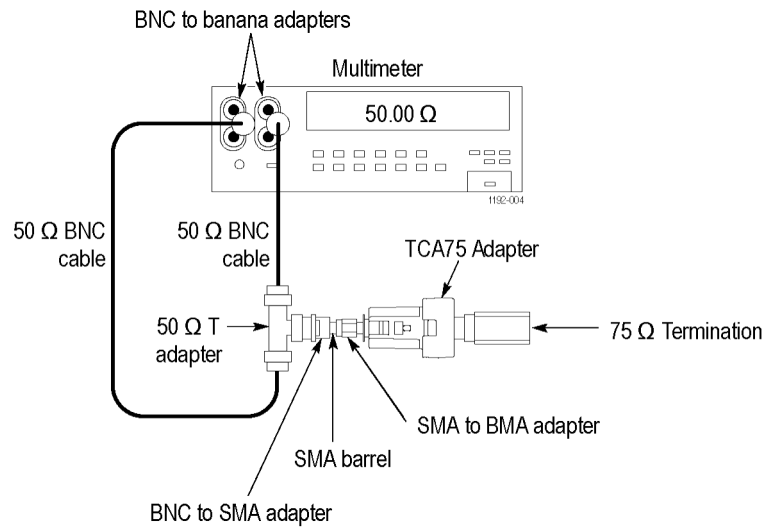

Figure 6: Test setup for output impedance

3. Check that the multimeter reads 49.25 Ω to 50.75 Ω .
4. Record the results in the test record.
5. Disconnect the setup.

Input impedance

This test checks the 75 Ω input impedance of the adapter.

1. Connect the TCA75 adapter as shown. (See Figure 7.)

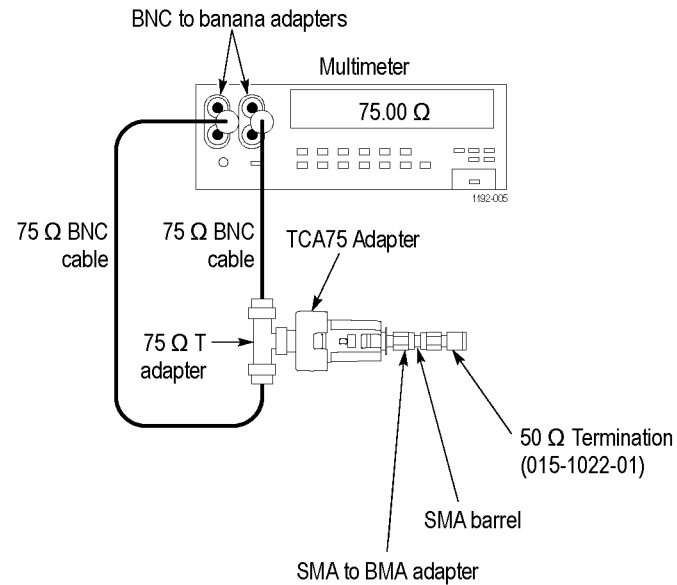

Figure 7: Test setup for input impedance

2. Check that the multimeter reads 73.875 Ω to 76.125 Ω .
3. Record the results in the test record.
4. Disconnect the setup.

Attenuation accuracy

1. Set up the equipment as follows:

Multimeter #1	Setting
Mode	DCV
Range	10 V (3-digit resolution)
Multimeter #2	
Mode	DCV
Range	1 V (3-digit resolution)
Power Supply	
DCV	1.000 V

2. Connect the equipment as shown. (See Figure 8.)

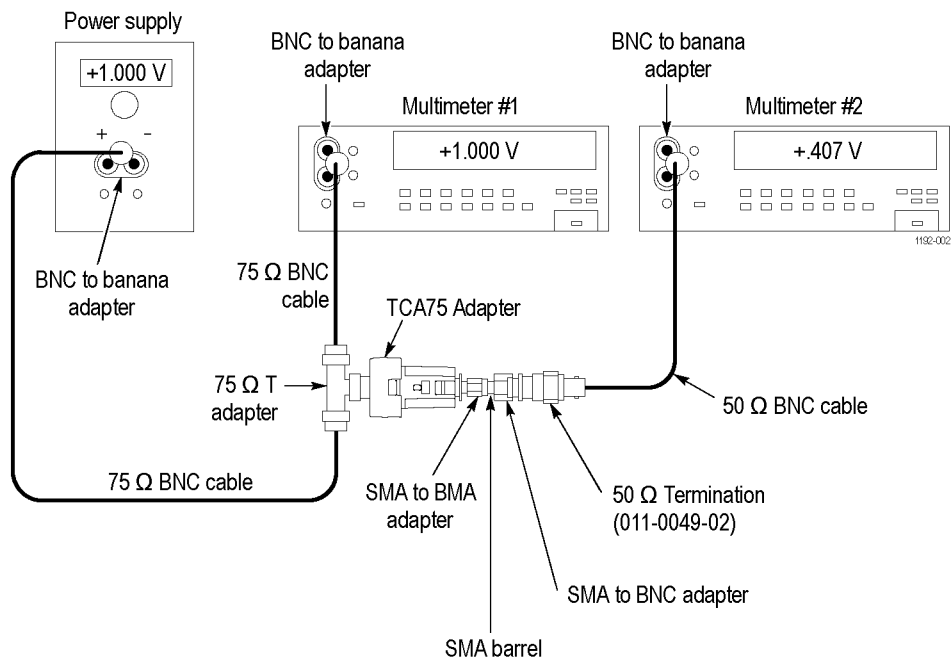

Figure 8: Test setup for attenuation accuracy

3. Power on the power supply, and adjust the output until multimeter #1 reads 1.000 V.
4. Check that the voltage is attenuated by $2.46X \pm 1.5\%$ (multimeter #2 reads 0.400 V to 0.413 V).
5. Record the measurement results in the test record.
6. Calculate the attenuation factor by dividing the voltage that you measured in step 4 (the adapter output) into 1.000 V (the adapter input, from step 3).

7. Record the calculated results in the test record.
8. Power off the power supply, and disconnect the test setup.

Probe calibration routine

This is a functional check of the TCA75 adapter that uses the probe calibration output signal and probe calibration feature of the oscilloscope.

1. Connect the TCA75 adapter to any channel on the oscilloscope.
2. Connect a 75 Ω coaxial cable between the TCA75 adapter input and the PROBE COMPENSATION output connector on the oscilloscope. The test setup is now connected as shown. (See Figure 9.)

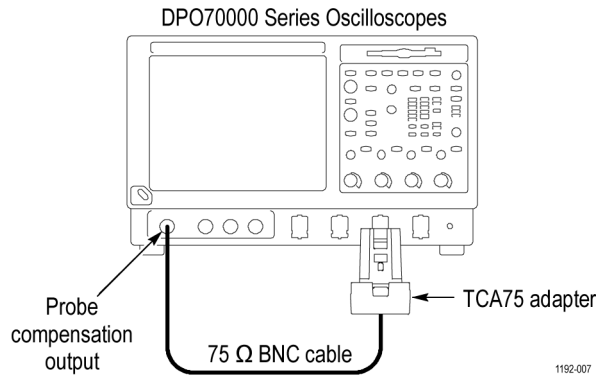

Figure 9: Probe calibration setup

3. Select Probe Cal from the Vertical menu on the oscilloscope.
4. When the calibration routine completes, verify that the Pass message displays. Record the results on the test record.

This completes the performance verification of the TCA75 adapter.

TCA75 test record

Photocopy this page and use it to record the performance test results for your TCA75 adapter.

Instrument number:

Temperature:

RH %:

Date of verification:

Technician:

TCA75 performance test	Minimum	Incoming	Outgoing	Maximum
Output impedance: 50 Ω	49.25			50.75
Input impedance: 75 Ω	73.875			76.125
Attenuation accuracy: 2.46 X (-6 dB) (measured with 1.0 V on the input)				
Input voltage	N/A	1.000	1.000	N/A
Output voltage	0.400			0.413
Input÷output = attenuation factor	2.497			2.423
Probe Calibration Routine	Pass/Fail			N/A