



# THDP0100/0200 & TMDP0200 High Voltage Differential Probes

## Installation and Safety Instructions



071-2890-04

Copyright © Tektronix. All rights reserved. Licensed software products are owned by Tektronix or its subsidiaries or suppliers, and are protected by national copyright laws and international treaty provisions.

Tektronix products are covered by U.S. and foreign patents, issued and pending. Information in this publication supersedes that in all previously published material. Specifications and price change privileges reserved.

TEKTRONIX and TEK are registered trademarks of Tektronix, Inc.

### **Contacting Tektronix**

Tektronix, Inc.

14150 SW Karl Braun Drive

P.O. Box 500

Beaverton, OR 97077

USA

For product information, sales, service, and technical support:

- In North America, call 1-800-833-9200.
- Worldwide, visit [www.tek.com](http://www.tek.com) to find contacts in your area.

## Important Safety Information

This manual contains information and warnings that must be followed by the user for safe operation and to keep the product in a safe condition.

To safely perform service on this product, additional information is provided at the end of this section. (See page 5, *Service Safety Summary*.)

### General Safety Summary

Use the product only as specified. Review the following safety precautions to avoid injury and prevent damage to this product or any products connected to it. Carefully read all instructions. Retain these instructions for future reference.

This product shall be used in accordance with local and national codes.

For correct and safe operation of the product, it is essential that you follow generally accepted safety procedures in addition to the safety precautions specified in this manual.

The product is designed to be used by trained personnel only.

Only qualified personnel who are aware of the hazards involved should remove the cover for repair, maintenance, or adjustment.

Before use, always check the product with a known source to be sure it is operating correctly.

This product is not intended for detection of hazardous voltages.

Use personal protective equipment to prevent shock and arc blast injury where hazardous live conductors are exposed.

## Important Safety Information

---

While using this product, you may need to access other parts of a larger system. Read the safety sections of the other component manuals for warnings and cautions related to operating the system.

When incorporating this equipment into a system, the safety of that system is the responsibility of the assembler of the system.

### To Avoid Fire or Personal Injury

**Connect and Disconnect Properly.** Do not connect or disconnect probes or test leads while they are connected to a voltage source.

Use only insulated voltage probes, test leads, and adapters supplied with the product, or indicated by Tektronix to be suitable for the product.

**Observe All Terminal Ratings.** To avoid fire or shock hazard, observe all ratings and markings on the product. Consult the product manual for further ratings information before making connections to the product. Do not exceed the Measurement Category (CAT) rating and voltage or current rating of the lowest rated individual component of a product, probe, or accessory.

Do not apply a potential to any terminal, including the common terminal, that exceeds the maximum rating of that terminal.

**Do Not Operate Without Covers.** Do not operate this product with covers or panels removed, or with the case open. Hazardous voltage exposure is possible.

**Avoid Exposed Circuitry.** Do not touch exposed connections and components when power is present.

**Do Not Operate With Suspected Failures.** If you suspect that there is damage to this product, have it inspected by qualified service personnel.

Disable the product if it is damaged. Do not use the product if it is damaged or operates incorrectly. If in doubt about safety of the product, turn it off and disconnect the power cord. Clearly mark the product to prevent its further operation.

Before use, inspect voltage probes, test leads, and accessories for mechanical damage and replace when damaged. Do not use probes or test leads if they are damaged, if there is exposed metal, or if a wear indicator shows.

Examine the exterior of the product before you use it. Look for cracks or missing pieces.

Use only specified replacement parts.

**Do Not Operate in Wet/damp Conditions.** Be aware that condensation may occur if a unit is moved from a cold to a warm environment.

**Do Not Operate in an Explosive Atmosphere.**

**Keep Product Surfaces Clean and Dry.** Remove the input signals before you clean the product.

### **Probes and Test Leads**

Before connecting probes or test leads, connect the power cord from the power connector to a properly grounded power outlet.

Keep fingers behind the protective barrier, protective finger guard, or tactile indicator on the probes.

## Important Safety Information

---

Remove all probes, test leads and accessories that are not in use.

Use only correct Measurement Category (CAT), voltage, temperature, altitude, and amperage rated probes, test leads, and adapters for any measurement.

**Beware of High Voltages.** Understand the voltage ratings for the probe you are using and do not exceed those ratings. The following rating is important to know and understand:

- The maximum measurement voltage for the probe tip.

The voltage rating depends on the probe and your application. Refer to the Specifications section of the manual for more information.



**WARNING.** *To prevent electrical shock, do not exceed the maximum measurement or maximum floating voltage for the oscilloscope input BNC connector, probe tip, or probe reference lead.*

*To prevent damage to the alligator clip insulation, do not use in high A/m magnetic fields at high frequencies, which can cause induction heating of the jaws.*

**Connect and Disconnect Properly.** Connect the probe output to the measurement product before connecting the probe to the circuit under test. Disconnect the probe input from the circuit under test before disconnecting the probe from the measurement product.

**Inspect the Probe and Accessories.** Before each use, inspect probe and accessories for damage (cuts, tears, or defects in the probe body, accessories, or cable jacket). Do not use if damaged.

### Service Safety Summary

The *Service safety summary* section contains additional information required to safely perform service on the product. Only qualified personnel should perform service procedures. Read this *Service safety summary* and the *General safety summary* before performing any service procedures.

**To Avoid Electric Shock.** Do not touch exposed connections.

**Do Not Service Alone.** Do not perform internal service or adjustments of this product unless another person capable of rendering first aid and resuscitation is present.

**Disconnect Power.** To avoid electric shock, switch off the product power and disconnect the power cord from the mains power before removing any covers or panels, or opening the case for servicing.

**Use Care When Servicing With Power On.** Dangerous voltages or currents may exist in this product. Disconnect power, remove battery (if applicable), and disconnect test leads before removing protective panels, soldering, or replacing components.

**Verify Safety After Repair.** Always recheck ground continuity and mains dielectric strength after performing a repair.

### Terms in this Manual

These terms may appear in this manual:



**WARNING.** *Warning statements identify conditions or practices that could result in injury or loss of life.*



**CAUTION.** *Caution statements identify conditions or practices that could result in damage to this product or other property.*

### Symbols and Terms on the Product

These terms may appear on the product:

- **DANGER** indicates an injury hazard immediately accessible as you read the marking.
- **WARNING** indicates an injury hazard not immediately accessible as you read the marking.
- **CAUTION** indicates a hazard to property including the product.



When this symbol is marked on the product, be sure to consult the manual to find out the nature of the potential hazards and any actions which have to be taken to avoid them. (This symbol may also be used to refer the user to ratings in the manual.)

The following symbol(s) may appear on the product:



**CAUTION**  
Refer to Manual



Earth Terminal



**WARNING**  
High Voltage



## Compliance Information

This section lists the safety and environmental standards with which the instrument complies. This product is intended for use by professionals and trained personnel only; it is not designed for use in households or by children.

Questions about the following compliance information may be directed to the following address:

Tektronix, Inc.  
PO Box 500, MS 19-045  
Beaverton, OR 97077, USA  
[www.tek.com](http://www.tek.com)

## Safety Compliance

This section lists the safety standards with which the product complies and other safety compliance information.

### EU Low Voltage Directive

Compliance was demonstrated to the following specification as listed in the Official Journal of the European Union:

Low Voltage Directive 2014/35/EU.

- EN 61010-031. Particular requirements for handheld probe assemblies for electrical measurement and test equipment.

### **U.S. Nationally Recognized Testing Laboratory Listing**

- UL 61010-031. Particular requirements for handheld probe assemblies for electrical measurement and test equipment.

### **Canadian Certification**

- CAN/CSA-C22.2 No. 61010-031. Particular requirements for handheld probe assemblies for electrical measurement and test equipment.

### **Additional Compliances**

- IEC 61010-031. Particular requirements for handheld probe assemblies for electrical measurement and test equipment.

### **Equipment Type**

Test and measuring equipment.

## Pollution Degree Descriptions

A measure of the contaminants that could occur in the environment around and within a product. Typically the internal environment inside a product is considered to be the same as the external. Products should be used only in the environment for which they are rated.

- Pollution degree 1. No pollution or only dry, nonconductive pollution occurs. Products in this category are generally encapsulated, hermetically sealed, or located in clean rooms.
- Pollution degree 2. Normally only dry, nonconductive pollution occurs. Occasionally a temporary conductivity that is caused by condensation must be expected. This location is a typical office/home environment. Temporary condensation occurs only when the product is out of service.
- Pollution degree 3. Conductive pollution, or dry, nonconductive pollution that becomes conductive due to condensation. These are sheltered locations where neither temperature nor humidity is controlled. The area is protected from direct sunshine, rain, or direct wind.
- Pollution degree 4. Pollution that generates persistent conductivity through conductive dust, rain, or snow. Typical outdoor locations.

## Pollution Degree Rating

Pollution degree 2 (as defined in IEC 61010-1). Rated for indoor, dry location use only.

## IP Rating

IP20 (as defined in IEC 60529).

### Measurement and Overvoltage Category Descriptions

Measurement terminals on this product may be rated for measuring mains voltages from one or more of the following categories (see specific ratings marked on the product and in the manual).

- Category II. Circuits directly connected to the building wiring at utilization points (socket outlets and similar points).
- Category III. In the building wiring and distribution system.
- Category IV. At the source of the electrical supply to the building.

*NOTE. Only mains power supply circuits have an overvoltage category rating. Only measurement circuits have a measurement category rating. Other circuits within the product do not have either rating.*

### Mains Overvoltage Category Rating

Overvoltage category II (as defined in IEC 61010-1).

## Environmental Considerations

This section provides information about the environmental impact of the product.

### Restriction of Hazardous Substances

Complies with RoHS2 Directive 2011/65/EU.

### Product End-of-Life Handling

Observe the following guidelines when recycling an instrument or component:

**Equipment Recycling.** Production of this equipment required the extraction and use of natural resources. The equipment may contain substances that could be harmful to the environment or human health if improperly handled at the product's end of life. To avoid release of such substances into the environment and to reduce the use of natural resources, we encourage you to recycle this product in an appropriate system that will ensure that most of the materials are reused or recycled appropriately.



This symbol indicates that this product complies with the applicable European Union requirements according to Directives 2012/19/EU and 2006/66/EC on waste electrical and electronic equipment (WEEE) and batteries. For information about recycling options, check the Tektronix Web site ([www.tek.com/productrecycling](http://www.tek.com/productrecycling)).

## Operating Considerations

| Specification   | THDP0100  | THDP0200  | TMDP0200  |
|---|---|---|---|
| Bandwidth   | 100 MHz   | 200 MHz   | 200 MHz   |
| Maximum measurable differential voltage <sup>1</sup>                                    | 600 V Range:<br>600 V DC + peak AC<br>450 V <sub>rms</sub><br>6000 V Range:<br>6000 V DC + peak AC<br>3000 V <sub>rms</sub> | 150 V Range:<br>150 V DC + peak AC<br>100 V <sub>rms</sub><br>1500 V Range:<br>1500 V DC + peak AC<br>1000 V <sub>rms</sub> | 75 V Range:<br>75 V DC + peak AC<br>50 V <sub>rms</sub><br>750 V Range:<br>750 V DC + peak AC<br>500 V <sub>rms</sub> |
| Maximum common mode voltage and input voltage-to-earth (V <sub>rms</sub> ) <sup>2</sup> | ±6000 V DC + peak AC<br>2300 V CAT I<br>1000 V CAT III  | ±1500 V DC + peak AC<br>1000 V CAT II<br>600 V CAT III  | ±750 V DC + peak AC<br>550 V CAT I<br>300 V CAT III   |
| Maximum Rated Over-Voltage Transient (OVT) <sup>3</sup>                                 | 4600 V <sub>pk</sub>  | NA  | 3220 V <sub>pk</sub>  |

- Beyond these limits, the output could be clipped. (See Figure 1 on page 13.)
- The Common Mode and input voltage-to-earth ratings are the maximum ratings of each input lead (+/-) to ground. (See Figure 1 on page 13.)
- Applies to CAT I ratings only (both ranges). OVT peak is measured on top of the Peak Working Voltage.

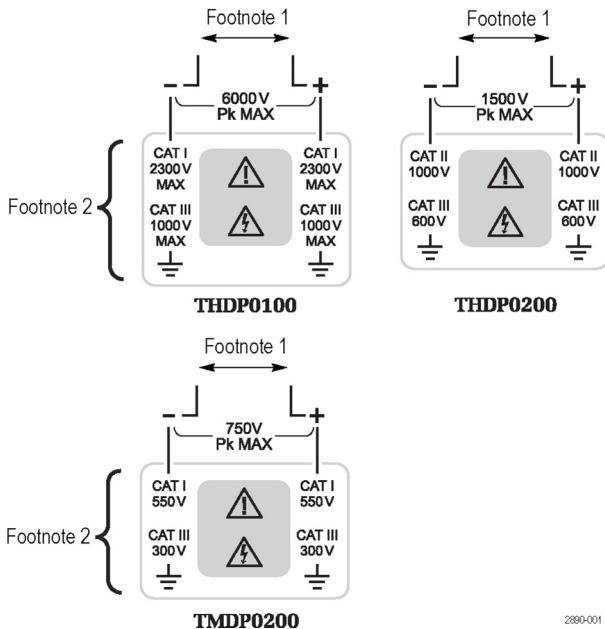

2890-001

Figure 1: Specification table footnotes referring to the probe input limits on the probes

**Table 1: Environmental specifications**

| <b>Characteristic</b> | <b>Specification</b>   |
|-----------------------|--|
| Temperature           |  |
| Operating             | 0 °C to +40 °C (+32 °F to +104 °F)   |
| Nonoperating          | -30 °C to +70 °C (-22 °F to +158 °F)   |
| Humidity              |  |
| Operating             | 5 to 85% R.H. 0 °C to +40 °C (+32 °F to +104 °F)   |
| Nonoperating          | 5 to 85% R.H. 0 °C to +40 °C (+32 °F to +104 °F)<br>5 to 45% R.H. above 40 °C to +70 °C (+104 °F to +158 °F) |
| Altitude              |  |
| Operating             | Up to 3000 m (9,842 ft.)   |
| Nonoperating          | Up to 15,240 m (50,000 ft.)  |
| Pollution degree      | 2, Indoor use only   |



## Installation

This booklet describes the installation and safe use of the probe and accessories. For more information, download the *THDP0100/0200 & TMDP0200 High Voltage Differential Probes Instruction Manual* from [tek.com](http://tek.com).

### Connecting the Probe to the Oscilloscope

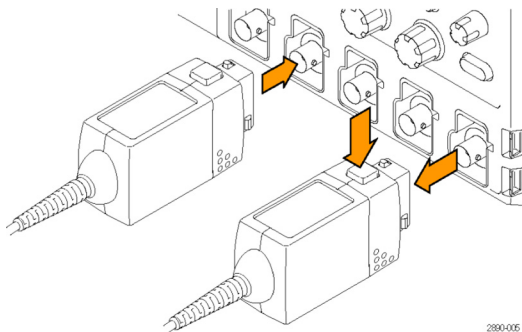

To connect the probe to the oscilloscope, align the probe to the input channel and push in the probe until it latches into place.

To disconnect the probe, first disconnect the probe from the circuit. Next, press the release button on the probe, and then pull the probe straight out.

### Connecting the Probe to the Circuit

The integral input leads on the probe extend 10 in (25 cm) from the probe body. Connect the leads directly to your circuit, or use the extender leads and the accessories that are included with the probe. (See page 17, *Standard Accessories*.)

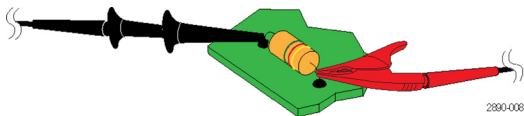

**WARNING.** To reduce risk of shock or fire, use only the accessories provided with the probe. Do not exceed either the voltage rating or category ratings (for example, CAT I, II, III, IV) of the probe or the probe accessory, whichever is the lesser of the two. Refer to the tables on the following pages for the correct accessory to use with your probe. When using multiple accessories (for example, the extender leads & hook clips), the lowest accessory/probe ratings apply to all.

To avoid electric shock, keep your fingers behind the finger guard of the probe accessory and away from the shaded area shown in the accessory illustrations on the following pages.

To avoid electrical shock or fire, keep the probe body and output cable of the probe away from the circuits being measured. The probe body and output cable are not intended to be in contact with the circuits being measured.

## Standard Accessories

### THDP0100 probe standard accessories

#### Item



2890-007

#### Description

Extender leads (196-3523-xx)

The female banana connectors on one end of the leads fit into the probe input leads. Use the extender leads to connect the probe to the test probes below. The test probes accept the hook tips in the THDP0100 probe accessory kit.

**WARNING.** *To avoid electrical shock or fire, make sure the test leads are in good condition. The input leads and extender leads have a jacket wear indicator which becomes visible if the wire jacket become excessively worn. If the wear indicator is visible, do not use the probe. Contact Tektronix Service for repair or replacement.*

Maximum ratings:

2300 V CAT I

1000 V CAT III

### THDP0100 probe standard accessories, (cont.)

#### Item

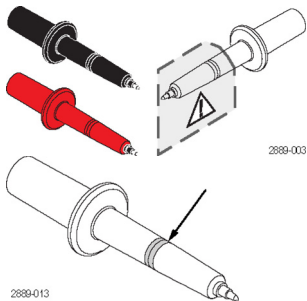

#### Description

Test probes (TATP) (020-3070-xx kit)

Use these test probes to browse multiple test points or to connect the extender leads to the hook tips.



**WARNING.** To prevent arc flash, use caution when probing circuits with raised components. Avoid getting the metal shell between components of different potentials. Use TASH for probing in hard-to-reach areas.

Maximum ratings:

2300 V CAT I

1000 V CAT II

---

## THDP0100 probe standard accessories, (cont.)

## Item

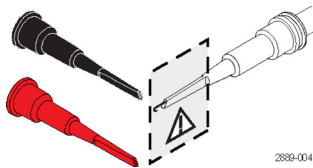

2889-004



## Description

Small hook tips (TASH) (020-3070-xx kit)

Use these tips to access test points in tight spaces. Screw the hook tips onto the TATP test probes and then clamp the hooks onto the circuit.

***WARNING.** To reduce the risk of shock when measuring voltages above 1000 V, always keep your fingers behind the tactile indicator on the TASH and TALH hook tips.*

Maximum ratings:

2300 V CAT I

1000 V CAT II

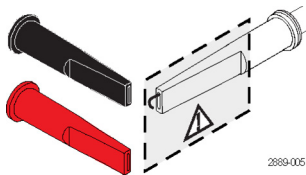

2889-005

Large hook tips (TALH) (020-3070-xx kit)

Screw the hook tips onto the TATP test probes and then clamp the hooks onto the circuit.

Maximum ratings:

2300 V CAT I

1000 V CAT II

THDP0100 probe standard accessory derating table

Combined probe and accessory common-mode voltage and input voltage-to-earth ratings

| Accessory                       | THDP0100                       | THDP0200 <sup>1</sup>          | TMDP0200 <sup>1</sup>        |
|---------------------------------|--------------------------------|--------------------------------|------------------------------|
| Extender leads<br>(196-3523-xx) | 2300 V CAT I<br>1000 V CAT III | 1000 V CAT II<br>600 V CAT III | 550 V CAT I<br>300 V CAT III |
| Test probes<br>(TATP)           | 1000 V CAT I<br>1000 V CAT II  | 1000 V CAT II<br>600 V CAT II  | 550 V CAT I<br>300 V CAT II  |
| Small hook tips<br>(TASH)       | 2300 V CAT I<br>1000 V CAT II  | 1000 V CAT II<br>600 V CAT II  | 550 V CAT I<br>300 V CAT II  |
| Large hook tips<br>(TALH)       | 2300 V CAT I<br>1000 V CAT II  | 1000 V CAT II<br>600 V CAT II  | 550 V CAT I<br>300 V CAT II  |

<sup>1</sup> The THDP0200 and TMDP0200 probes can also be used with the THDP0100 standard accessories, but only at the reduced voltage levels listed in this table.



**WARNING.** To avoid risk of electric shock or fire, when using the THDP0100 test probe or hook tip accessories with the THDP0200 and TMDP0200 probes, do not use on circuits above 1000 V.

To avoid risk of electric shock or fire, do not use the THDP0100 test probe or hook tip accessories on CAT III or CAT IV circuits. Refer to the derating table above.

## THDP0200 and TMDP0200 probe standard accessories

## Item

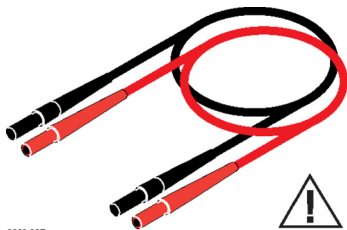

2890-007

## Description

Extender leads (196-3523-xx)

The female banana connectors on each end of the leads fit into the probe input jacks. Use the extender leads to connect the probe to your circuit, either directly or through any of the standard accessories described below.

**WARNING.** *To avoid electrical shock or fire, make sure the test leads are in good condition. The input leads and extender leads have a jacket wear indicator which becomes visible if the wire jacket become excessively worn. If the wear indicator is visible, do not use the probe. Contact Tektronix Service for repair or replacement.*

Maximum ratings:  
2300 V CAT I  
1000 V CAT III

### THDP0200 and TMDP0200 probe standard accessories, (cont.)

#### Item

#### Description

---

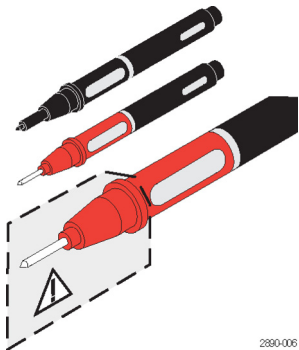

Handheld probes (TP175)

These probes plug onto the banana input leads and extender leads. The tips are threaded to accept tip accessories.

The insulator sheath at the probe tip extends and retracts into CAT III and CAT IV-rated spacings. Twist the probe body past the detent at each end of the twist to lock the probe into the CAT setting.

Maximum ratings:

1000 V CAT II

1000 V CAT III

10 A

**NOTE.** Order the TP175 at Fluke.

---

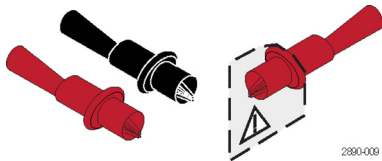

Crocodile clips (344-0670-xx)

These clips screw on to the threaded tips of the handheld probes. The crocodile clips connect easily to large bolts or bus bars.

Maximum ratings:

1000 V CAT III

10 A

---



## THDP0200 and TMDP0200 probe standard accessories, (cont.)

## Item

## Description

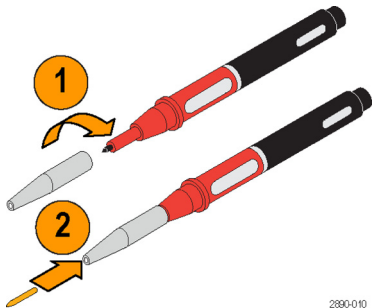

2890-010

Pogo pin tip adapter & tips kit  
(020-3107-xx)

These insulated adapters screw on to the threaded tips of the TP175 handheld probes. The adapters hold the pogo pin tips included in the kit.

Maximum ratings:  
150 V CAT II  
1 mA



Extended test probe adapters  
(012-1724-xx)

These adapters screw on to the threaded tips of the handheld probes. The sharp tips can contact small component leads and circuit board features.

Maximum ratings:  
300 V CAT II  
3 A

### THDP0200 and TMDP0200 probe standard accessories, (cont.)

#### Item

#### Description

---

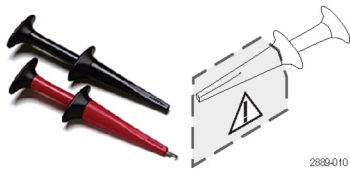

Hook clips (AC280-FL)

Use these clips to make connections to component leads.

Maximum ratings:  
1000 V CAT III  
600 V CAT IV

---



Pincer clips (AC283-FL)

These clips have a pair of finer contacts that close around leads on smaller components.

Maximum ratings:  
1000 V CAT III  
600 V CAT IV

---



Alligator clips (AC285-FL)

The large insulated clips connect easily to large bolts or bus bars. The connectors are double insulated for safety.

Maximum ratings:  
1000 V CAT III  
600 V CAT IV

---

## THDP0200 and TMDP0200 probe standard accessory derating table

**Combined probe and accessory common-mode  
voltage and input voltage-to-earth ratings**

| <b>Accessory</b>                                | <b>THDP0100<sup>1</sup></b>    | <b>THDP0200</b>                | <b>TMDP0200</b>              |
|---|--------------------------------|--------------------------------|------------------------------|
| Extender leads (196-3523-xx)                    | 2300 V CAT I<br>1000 V CAT III | 1000 V CAT II<br>600 V CAT III | 550 V CAT I<br>300 V CAT III |
| Handheld probes (TP175)                         | 1000 V CAT I<br>1000 V CAT III | 1000 V CAT II<br>600 V CAT III | 550 V CAT I<br>300 V CAT III |
| Crocodile clips (344-0670-xx)                   | 300 V CAT I                    | 300 V CAT I                    | 300 V CAT I                  |
| Pogo pin tip adapters and tips<br>(020-3107-xx) | 150 V CAT II                   | 150 V CAT II                   | 150 V CAT II                 |
| Extended test probe adapters<br>(012-1724-xx)   | 300 V CAT I<br>300 V CAT II    | 300 V CAT II                   | 300 V CAT I<br>300 V CAT II  |
| Hook clips (AC280-FL)                           | 1000 V CAT I<br>1000 V CAT III | 1000 V CAT II<br>600 V CAT III | 550 V CAT I<br>300 V CAT III |
| Pincer clips (AC283-FL)                         | 1000 V CAT I<br>1000 V CAT III | 1000 V CAT II<br>600 V CAT III | 550 V CAT I<br>300 V CAT III |
| Alligator clips (AC285-FL)                      | 1000 V CAT I<br>1000 V CAT III | 1000 V CAT II<br>600 V CAT III | 550 V CAT I<br>300 V CAT II  |

<sup>1</sup> The THDP0100 probe can be used with the THDP0200 and TMDP0200 accessories, but only at the reduced voltage levels listed in this table.

### Additional Standard Accessories for the THDP0200 and TMDP0200 Probes

The THDP0200 and TMDP0200 probes also include a probe holder as a standard accessory. (See Table 2.) This accessory is designed to help you take differential measurements and to make hands-free connections on your circuit.

**Table 2: Additional THDP0200 and TMDP0200 probe standard accessories**

| Item   | Description   |
|--|---|
|  A white plastic probe holder with a black and red probe inserted. The holder has a central slot for the probe and two side slots for fingers. The Tektronix logo is visible on the side. The part number 2890-003 is printed at the bottom right of the holder.<br>2890-003 | <p data-bbox="522 388 743 414">TPH1000 probe holder</p> <p data-bbox="522 426 902 601">The TPH1000 probe holder allows you to make a hands-free connection when using the handheld probes included in the accessory kit. The probe holder can also be used with many other Tektronix probes.</p> <p data-bbox="522 614 912 699">Always insert the handheld probe so that the Tektronix logo on the probe holder faces the circuit under test.</p> |



# Controls and Features

## Controls and features

### Item

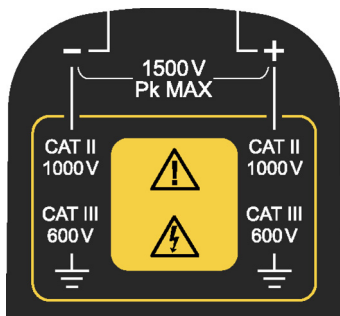

0536-001

### Description

#### Differential inputs

The differential and common-mode input voltage ratings for the probes differ between models.

The highest ratings are for the THDP0100 probe and are rated for a maximum peak voltage of 6000 V between the inputs.

The inputs are CAT I rated to a maximum of 2,300 V<sub>RMS</sub> between either input and earth ground.

The maximum Over-Voltage Transient (OVT) rating and other ratings for the all of the probe models are listed in this booklet. (See page 12, *Operating Considerations*.)

For complete specifications, download the *THDP0100/0200 & TMDP0200 High Voltage Differential Probes Instruction Manual* from [tek.com](http://tek.com).

### Controls and features, (cont.)

#### Item

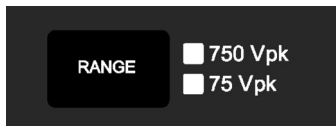

0540-020



0536-002

#### Description

---

##### Range selector button and indicators

Press the button to select between the voltage range (attenuation) settings of the probe. The range and units are indicated on the probe and may be displayed on the oscilloscope screen, depending on the oscilloscope model.

The OVERRANGE LED lights if the applied voltage exceeds the selected range. To extinguish the LED, select a higher range. If a higher range is not available, do not attempt to take the measurement with the probe. (See warning below.)

---



**WARNING.** *The Overrange indicator does not detect an overrange condition of common mode voltages or voltage-to-earth potential at the probe inputs. The Overrange indicator only detects differentially between the + and - inputs, not relative to ground. Do not exceed the common mode voltage or voltage-to-earth probe ratings when taking measurements. If you are not sure, first take a single-ended measurement of each point that you intend to measure differentially. Take a single-ended measurement by tying one input lead to ground (for example, the - input) and then connecting the other lead (for example, the + input) to the points of interest, one at a time.*

## Controls and features

## Item

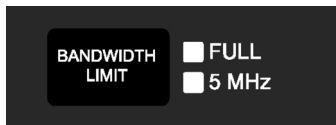

0540-021

## Description

**Bandwidth Limit button and indicators**

Press the button to limit the probe bandwidth to 5 MHz. The 5 MHz filter assists in the characterization and testing of power supplies in switch mode by removing all high frequency content, noise and harmonics from the measurement. 5 MHz is close to the switching frequency of most switching transistors (FETs) in switch-mode power supplies.

Press the button again to return to the FULL position, which selects the full specified bandwidth of the probe.



0636-005

**Audible Overrange On/Off button and indicators**

The audible alarm beeps when the measured signal exceeds the selected range. Press the button to disable the audible feature (the OFF LED lights).

Press the button again to enable the audible alarm (the ON LED lights).