

TekExpress®
10G-KR Compliance and Debug Solution
Online Help



TekExpress®
10G-KR Compliance and Debug Solution
Online Help

Copyright © Tektronix. All rights reserved. Licensed software products are owned by Tektronix or its subsidiaries or suppliers, and are protected by national copyright laws and international treaty provisions.

Tektronix products are covered by U.S. and foreign patents, issued and pending. Information in this publication supersedes that in all previously published material. Specifications and price change privileges reserved.

TEKTRONIX and TEK are registered trademarks of Tektronix, Inc.

TekExpress is a registered trademark of Tektronix, Inc.

TekExpress 10G-KR Compliance and Debug Solution Online Help, 076-0279-00.

Contacting Tektronix

Tektronix, Inc.
14150 SW Karl Braun Drive
P.O. Box 500
Beaverton, OR 97077
USA

For product information, sales, service, and technical support:

- In North America, call 1-800-833-9200.
- Worldwide, visit www.tektronix.com to find contacts in your area.

Table of Contents

Getting help and support

Related documentation	1
Conventions used in help	1
Technical support	2

Getting started

Installing the software	
Install the software	3
Activate the license	4
View software version and license information	6
Introduction to the application	
10G-KR features and benefits	7
Supported oscilloscopes	7
Minimum system requirements	8
Application directories and usage	10
File name extensions	12

Operating basics

Run the application	13
Exit the application	13
Application controls and menus	
Application controls	14
Options menu	
Options menu overview	14
Instrument control settings	16
Email settings	
Email settings	16
Configure email settings	17
Deskew	19
Application panels	
Application panel overview	21
Setup panel	
Setup panel overview	21
Set DUT parameters	22
Select tests	25
Acquisitions tab	
About acquisitions	26
Set acquisition parameters source	28

Set test notification preferences	29
Configure test parameters	
About configuring test parameters	30
Configure test parameters	30
Common test parameters	30
Status panel overview	33
Results panel	
Results panel overview	35
View test results	36
View test-related files	37
Reports panel	
Reports panel overview	37
Select report options	38
View a report	40
Report contents	41

Setting up and configuring tests

About setting up tests	43
Equipment connection setup	44
View connected instruments	46
Test setup overview	48

Running tests

About running tests	49
Before you click start	49
Pre-run checklist	51

Saving and recalling test setups

About test setups	53
Save a test setup	53
Recall a saved test setup	54
Create a new test setup based on an existing one	54

TekExpress programmatic interface

About the programmatic interface	55
Requirements for developing TekExpress client	55
Client programmatic interface example	56
Program example	59
10G-KR application commands	
About 10G-KR application commands	61
Connect through an IP address	68
Lock the server	69

Disable the popups.....	70
Set or get the DUT ID	71
Set the Configuration Parameters for a suite or measurement	72
Query the Configuration Parameters for a suite or measurement.....	74
Select a measurement	75
Select a suite.....	76
Select a channel	77
Configure the selected measurement	78
Run with set configurations or stop the run operation	79
Handle error codes.....	80
Get or set the timeout value.....	81
Wait for the test to complete.....	81
After the test is complete.....	84
Save, recall, or check if a session is saved	88
Unlock the server	89
Disconnect from the server	90

10G-KR tests

72.7.1.3 Signaling speed	91
72.7.1.4 Differential peak-to-peak output voltage (max).....	91
72.6.5 Differential peak-to-peak output voltage (max) with Tx disabled	92
72.7.1.4 Common mode voltage limits.....	93
72.7.1.7 Transition time.....	94
72.7.1.8 Max output jitter (peak-peak)	94
72.7.1.10 Transmitter output waveform characteristics	97
72.7.1.11a Output waveform coefficient update.....	97
72.7.1.11b Output waveform coefficient status.....	99

Reference



De-embed using filter files.....	101
Deskew channels	101
DPOJET option 10G-KR plug-in	102
Map the My TekExpress folder	107

Index

Related documentation

The following manuals are available as part of the TekExpress 10G-KR Compliance and Debug Solution documentation set.

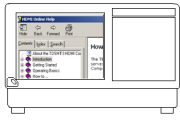
Table 1: Product documentation

Item	Purpose	Location
Online Help	In-depth operation and UI help	
PDF of the Online Help	In-depth operation and UI help	 www.Tektronix.com

See also

[Technical support \(see page 2\)](#)

Conventions used in help

Online Help uses the following conventions:

- The term “DUT” is an abbreviation for Device Under Test.
- The term “select” is a generic term that applies to the two mechanical methods of choosing an option: using a mouse or using the touch screen.

Technical support

Tektronix values your feedback on our products. To help us serve you better, please send us your suggestions, ideas, or comments on your application or oscilloscope. Contact Tektronix through mail, telephone, or the Web site. See [Contacting Tektronix](#) for more information.

When you contact Tektronix Technical Support, please include the following information (be as specific as possible):

General information

- All instrument model numbers
- Hardware options, if any
- Probes used
- Your name, company, mailing address, phone number, FAX number
- Please indicate if you would like to be contacted by Tektronix about your suggestion or comments.

Application specific information

- Software version number
- Description of the problem such that technical support can duplicate the problem
- If possible, save the setup files for all the instruments used and the application
- If possible, save the TekExpress setup files, log.xml, *.TekX (session files and folders), and status messages text file
- If possible, save the waveform on which you are performing the measurement as a .wfm file

Install the software

The software can be installed on any compatible instrument running Windows XP or Windows 7 (64-bit). See [Minimum System Requirements \(see page 8\)](#) for details.

1. Close all applications (including the TekScope application).
2. Go to the www.tek.com Web site and search for 10G-KR to locate the installation file. Download the file `10G-KRWebInstaller.exe`.
3. Double-click the executable file to extract the installation files.

After extraction, the installer launches and displays the InstallShield Wizard.

- Check **DPOJET Plug-In** to install the 10G-KR option plug-in to the TekScope DPOJET application.
- Check **TekExpress application for 10G-KR** to install the TekExpress 10G-KR application.

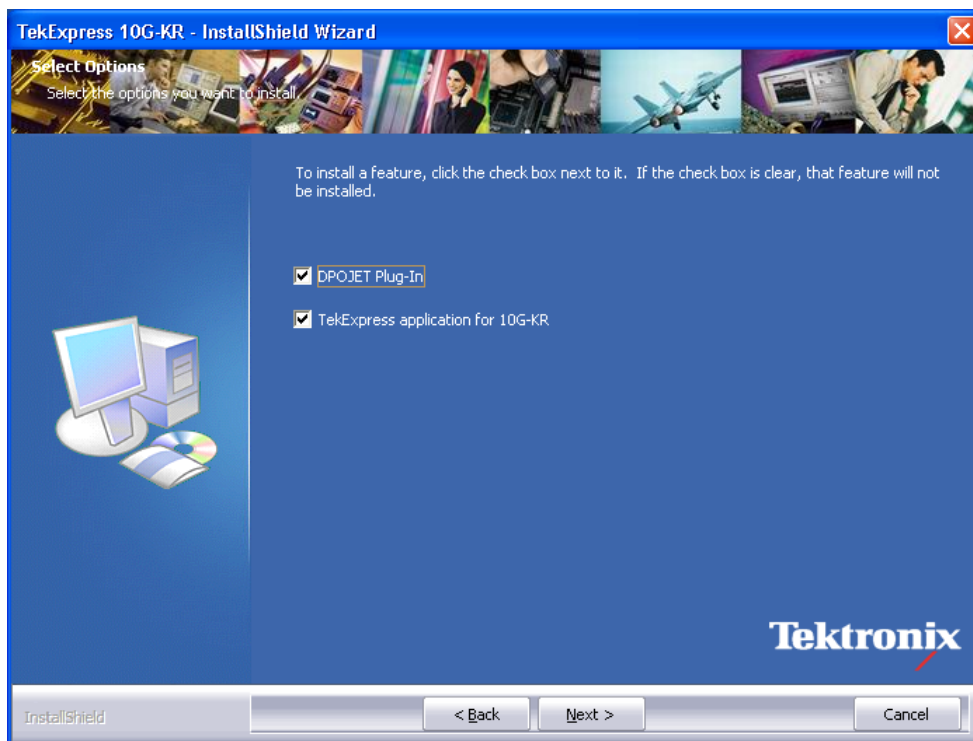

4. The software installs in the following location:
 - Windows 7 location: C:\Program Files (x86)\Tektronix\TekExpress\TekExpress 10G-KR
 - Windows XP location: C:\Program Files\Tektronix\TekExpress\TekExpress 10G-KR
5. The installer updates the TekScope Analyze menu to include the installed options.

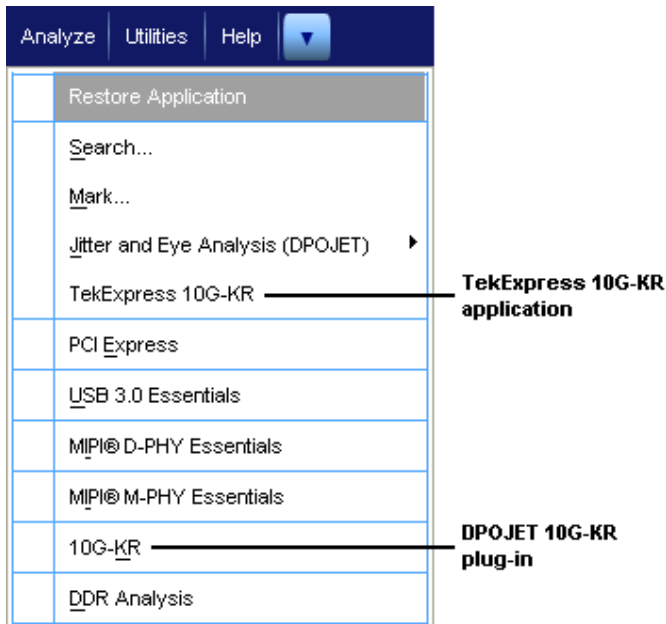

See also

[Minimum system requirements \(see page 8\)](#)

[Compatibility \(see page 7\)](#)

[DPOJET option 10G-KR plug-in \(see page 102\)](#)

Activate the license

The 10G-KR application runs in Evaluation mode if you do not provide a valid license key. You are allowed 10 free trials in Evaluation mode. Each time you open the application without supplying a valid license key, one free trial is used.

Activate the license using the Option Installation wizard on the oscilloscope. Instructions for using the Options Installation window to activate licenses for installed applications is provided in the oscilloscope online Help:

1. From the oscilloscope menu bar, click **Utilities > Option Installation**.

The TekScope Option Installation wizard opens.

2. Press the **F1** key on the oscilloscope keyboard to open the Option Installation help topic. Follow the directions in the topic to activate the license.

See also

[View version and license information \(see page 6\)](#)

View software version and license information

Use the following instructions to view version information for the application and for the application modules such as the Programmatic Interface and the Programmatic Interface Client.

To view version information:

1. From the Options menu, select About TekExpress.



2. Click the View Version Details link to check the version numbers of the installed test suites.

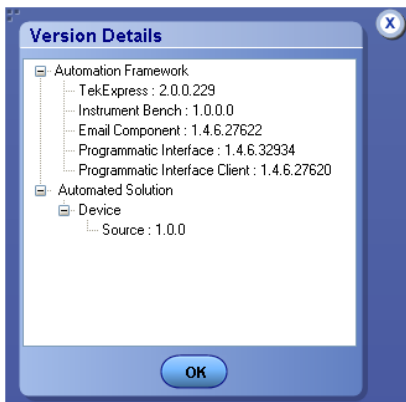

To view license information:

1. From the oscilloscope Help menu, select **About TekScope**.

The Options section in the dialog box displays a list of installed options, including 10G-KR.

2. To view the Option key, look in the Option installation key section.

See also

[Activate the license \(see page 4\)](#)

[Options menu \(see page 14\)](#)

10G-KR features and benefits

Welcome to the TekExpress® 10G-KR Transmitter Automated Solution application. 10G-KR provides an automated, simple, and efficient way to test 10G-KR Transmitter interfaces and devices consistent to the requirements of the IEEE 802.3ap-2007 specifications.

10G-KR is based on TekExpress version 2, the Tektronix Test Automation Framework, developed to support your current and future test automation needs. TekExpress uses a highly modular architecture that lets you deploy automated test solutions for various standards.

- Automates compliance measurements for IEEE 802.3ap-2007 specifications
- Automated test setup for measuring transmitter equalization levels generating 72 results, 12 results for each tap
- Provides both an automation solution (for compliance) and DPOJET (for debug)
- RF switch support for four lanes of KR4
- Reduces the time required to conduct testing
- Minimizes user intervention when conducting time-consuming testing
- Provision for entering filter files to de-embed the effects of backplane traces and any other components in the signal pathway
- Performs fully-automated testing for transmitter measurements
- Allows you to select individual tests or test groups in the tree-structure
- Built-in reporting features
 - Provides a Pass/Fail summary table
 - Provides margin details on each test
 - Provides a consolidated report for all tests
- Complete programmatic interface available; users can call 10G-KR functions using their automation scripts

Supported oscilloscopes

The TekExpress 10G-KR application runs on the following Tektronix oscilloscopes:

- DPO/DSA/MSO71604/B/C Series Digital Oscilloscopes
- DPO/DSA/MSO72004/B/C Series Digital Oscilloscopes
- DPO/DSA72504D and DPO/DSA73304D Series Digital Oscilloscopes

See also

[Minimum system requirements \(see page 8\)](#)

Minimum system requirements

The following table shows the minimum system requirements needed for an oscilloscope to run TekExpress.

Table 2: System requirements

Oscilloscope	See Supported oscilloscopes (see page 7)
Processor	Same as the oscilloscope
Operating System	Same as the oscilloscope: <ul style="list-style-type: none"> ■ Windows 7 (64-bit only) ■ Windows XP (32-bit) SP2 and higher
Memory	Same as the oscilloscope
Hard Disk	Same as the oscilloscope
Display	Same as the oscilloscope ¹
Firmware	<ul style="list-style-type: none"> ■ TekScope 5.3.4 (Windows XP) ■ TekScope 6.1.4 and later (Windows 7)

Table 2: System requirements (cont.)

Software	<ul style="list-style-type: none"> ■ DPOJET, Jitter and Eye Diagram Analysis Tool, 3.4.0.17 or later ■ National Instruments LabVIEW Run-time Engine 9.0.1 or later ■ National Instruments TestStand Engine 4.2.1 ■ Microsoft .NET 4.0 Framework ■ Microsoft Excel 2002 or above ■ Microsoft Internet Explorer 6.0 SP1 or later ■ Microsoft Photo Editor 3.0 or equivalent software for viewing image files ■ Adobe Reader 7.0 or equivalent software for viewing portable document format (PDF) files
Other Devices	<ul style="list-style-type: none"> ■ Microsoft compatible mouse or compatible pointing device ■ Four USB ports (two USB ports minimum) ■ PCI-GPIB or equivalent interface for instrument connectivity²

¹ If TekExpress is running on an instrument having a video resolution lower than 800x600 (for example, a sampling oscilloscope), it is recommended that you connect a secondary monitor, which must be enabled before launching the application.

² If TekExpress is installed on a Tektronix oscilloscope, TekExpress will use the virtual GPIB port for communicating with oscilloscope applications. If external GPIB communication devices such as USB-GPIB-HS or equivalent are used for instrument connectivity, make sure that the Talker Listener utility is enabled in the GPIB menu of the DPO/DSA oscilloscope. For ease of use, connect to an external (secondary) monitor.

User Account Control

On Windows 7 instruments, set User Account Control Settings to Never Notify. To set User Account Control Settings, go to Control Panel > User Accounts > Change User Account Control settings and set it to Never Notify as shown in the image.

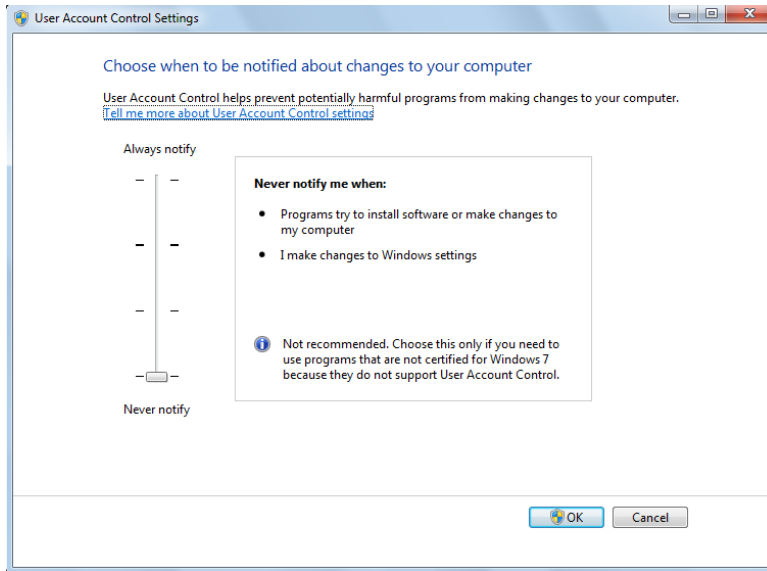

See also

[Supported oscilloscopes \(see page 7\)](#)

Application directories and usage

The application directory and associated files are organized as follows:

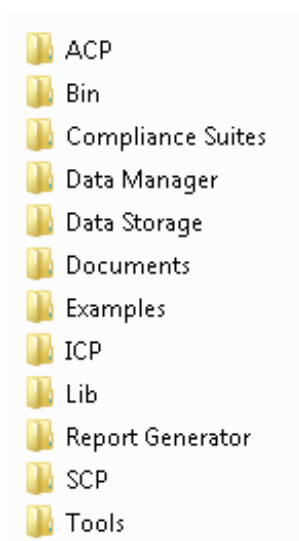

The following table lists the default directory names and their usage.

Table 3: Application directories and usage

Directory names	Usage
InstallDir\TekExpress\TekExpress 10G-KR	Contains the application and associated files
TekExpress 10G-KR\ACP	Contains instrument and 10G-KR application-specific interface libraries
TekExpress 10G-KR\Bin	Contains miscellaneous 10G-KR application libraries
TekExpress 10G-KR\Compliance Suites	Contains compliance-specific files
TekExpress 10G-KR\Data Manager	Contains result management-specific libraries of the 10G-KR application
TekExpress 10G-KR\Data Storage	Contains libraries needed for storing data
TekExpress 10G-KR\Documents	Contains the technical documentation for the 10G-KR application
TekExpress 10G-KR\Examples	Contains various support files
TekExpress 10G-KR\ICP	Contains instrument and 10G-KR application-specific interface libraries
TekExpress 10G-KR\Lib	Contains utility files specific to the 10G-KR application
TekExpress 10G-KR\Report Generator	Contains Excel Active X interface Library for Report Generation
TekExpress 10G-KR\SCP	Contains instrument and 10G-KR application-specific interface libraries
TekExpress 10G-KR\Tools	Contains instrument and 10G-KR application-specific files

See also

[View test-related files \(see page 37\)](#)

[File name extensions \(see page 12\)](#)

File name extensions

The TekExpress 10G-KR application uses the following file name extensions:

File name extension	Description
.TekX	Session files are saved in this format but the extensions may not be displayed.
.seq	The test sequence file
.xml	The encrypted XML file that contains the test-specific configuration information The log file extension is also xml
.wfm	The test waveform file
.mht	Test result reports are saved in this format by default. Test reports can also be saved in HTML format (see page 38) .
.flt	The filter files.

See also

[Select report options \(see page 38\)](#)

[View test-related files \(see page 37\)](#)

[Application directories and usage \(see page 10\)](#)

[Before you click start \(see page 49\)](#)

Run the application

To run the 10G-KR application, do either of the following:

- Select **Analyze > TekExpress 10G-KR** from the TekScope menu.
- Double-click any saved 10G-KR session file.

When you open the application after installation, the application checks for a file called `Resources.xml` located in the `My TekExpress` folder. If this file is not found, instrument discovery is performed before launching 10G-KR. The `Resources.xml` file contains information regarding instruments that are available on your network.

If the application license was not installed using the TekScope menu **Utilities > Option Installation** selection, you can open the application up to 10 times in evaluation mode. Each time you open the application without supplying a valid license key, one of the free trials is used.

To keep the application window on top, select **Keep On Top** from the [Options menu \(see page 14\)](#).

NOTE. *If the application was not terminated properly during the last use, a dialog box asks to recall the previously unsaved session.*

See also

[Activate the license \(see page 4\)](#)

Exit the application





Use the following method to exit the application:

NOTE. *Using other methods to exit the application results in abnormal termination of the application.*

1. Click  on the application title bar.
2. Do one of the following:
 - If you have an unsaved session or test setup open, you will be asked to save it before exiting. To save it, click **Yes**. Otherwise click **No**. The application closes.
 - A message box appears asking if you really want to exit TekExpress. To exit, click **Yes**.

Application controls

Table 4: Application controls descriptions

Item	Description
Options menu (see page 14)	Opens the Options menu for access to global controls
Panels (see page 21)	Visual frames with sets of related options
Command buttons	Buttons that initiate an immediate action such as the Start, Stop, Pause, Continue, and Clear command buttons
Start button	<p>Start</p>  <p>Use the Start button to continuously acquire and accumulate measurements. If prior acquired measurements have not been cleared, the new measurements are added to the existing set.</p>
Stop button	<p>Stop</p>  <p>Use the Stop button to abort the test.</p>
Pause \ Continue button	<p>Pause Continue</p>  <p>Use the Pause button to temporarily interrupt the current acquisition. When a test is paused, the button name changes to "Continue."</p>
Clear button	<p>Clear</p>  <p>Use the Clear button to clear all existing measurement results. Adding or deleting a measurement, or changing a configuration parameter of an existing measurement, also clears measurements. This is to prevent the accumulation of measurement statistics or sets of statistics that are not coherent. This button is available only on the Results panel (see page 35).</p>
Application window move icon	 <p>Place the cursor over the three-dot pattern in the upper left corner of the application window. When the cursor changes to a hand, drag the window to the desired location.</p>

Options menu overview

The Options menu is located in the upper right corner of the application.

The [Options menu \(see page 15\)](#) has the following selections:

Menu	Function
Default Test Setup	Opens an untitled test setup with defaults selected
Open Test Setup	Opens a saved test setup
Save Test Setup	Saves the current test setup selections
Save Test Setup As	Creates a new test setup based on an existing one
Open Recent	Displays a menu of recently opened test setups to select from
Instrument Control Settings (see page 16)	Shows the list of instruments connected to the test setup and allows you to locate and refresh connections to those instruments
Keep On Top	Keeps the TekExpress 10G-KR utility on top of other open windows on the desktop
Email Settings (see page 16)	Use to configure email options for test run and results notifications
Deskew (see page 101)	Use to deskew channels
Help	Displays TekExpress Help
About TekExpress	<ul style="list-style-type: none"> ■ Displays application details such as software name, version number, and copyright ■ Provides access to license information (see page 6) for your 10G-KR installation ■ Provides a link to the Tektronix Web site

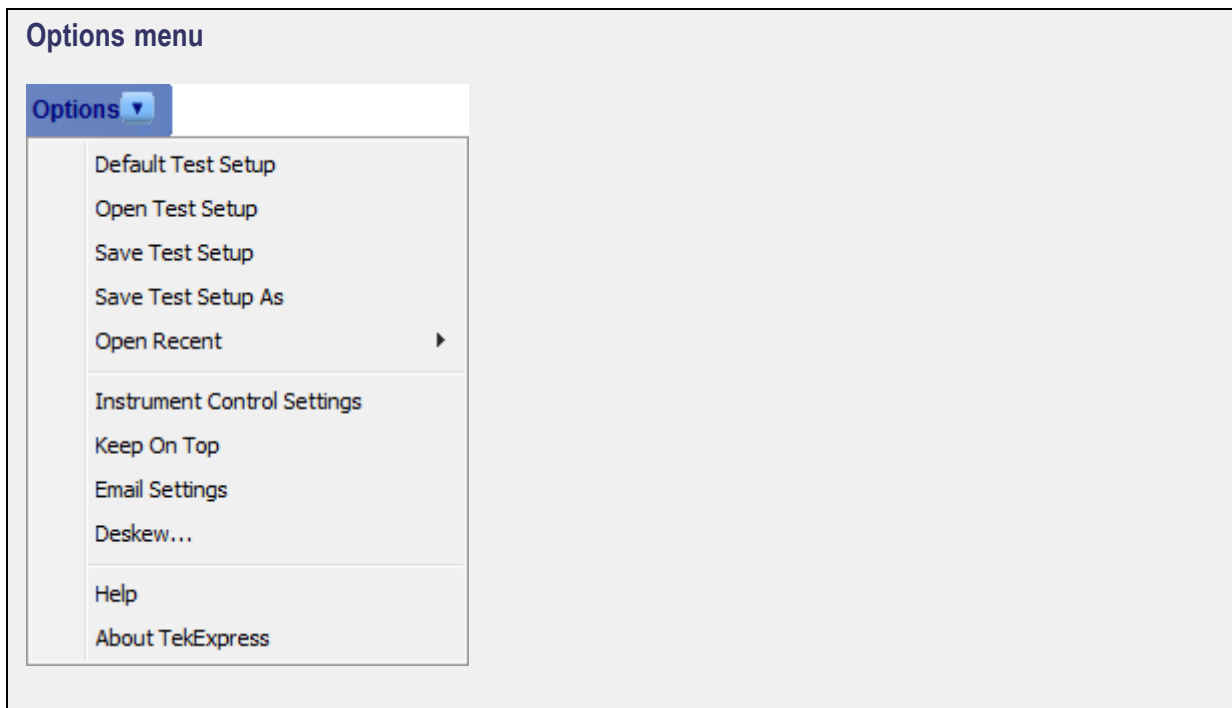

See also

[Application controls \(see page 14\)](#)

Instrument control settings

Use the TekExpress Instrument Control Settings dialog box to search for and list the connected resources (instruments) found on specified connections (LAN, GPIB, USB, and so on) and each instruments connection information. You access this dialog box from the Options menu.

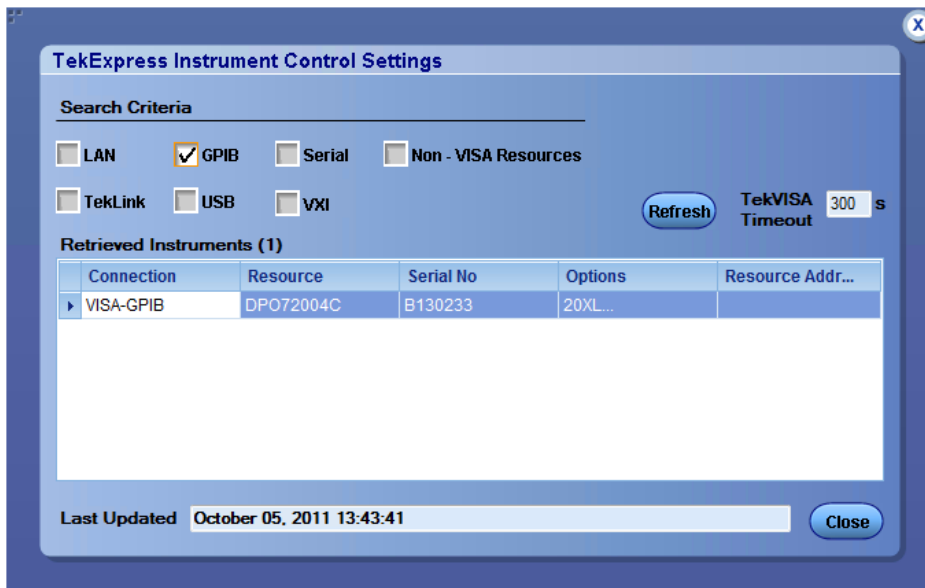

Use the Instrument Control Settings feature to [search for connected instruments \(see page 46\)](#) and view instrument connection details. Connected instruments displayed here can be selected for use under Global Settings in the test configuration section. See step 2 of [Configure tests \(see page 30\)](#) for details.

See also

[Options menu overview \(see page 14\)](#)

Email settings

Use the Email Settings utility to [configure email notifications \(see page 17\)](#) if you want to receive notifications when a test completes, produces an error, or fails. Select the type of test session information to include in the notification, such as test reports and test logs, the email message format, and the email message size limit.

NOTE. Recipient email address, sender's address, and SMTP Server are mandatory fields.

See also

[Configure email settings \(see page 17\)](#)

[Options menu \(see page 14\)](#)

[Select test notification preferences \(see page 29\)](#)

Configure email settings

To be notified by email when a test completes, fails, or produces an error, configure the email settings.

1. **Options > Email Settings** to open the [Email Settings \(see page 19\)](#) dialog box.
2. (Required) For Recipient email Address(es), enter one or more email addresses to which to send the test notification. To include multiple addresses, separate the addresses with commas.
3. (Required) For Sender's Address, enter the email address used by the instrument. This address consists of the instrument name followed by an underscore followed by the instrument serial number, then the @ symbol and the email server used. For example: DPO72016C_B130099@yourcompany.com.
4. (Required) In the Server Configuration section, type the SMTP Server address of the Mail server configured at the client location, and the SMTP Port number, in the corresponding fields.

If this server requires password authentication, enter a valid login name, password, and host name in the corresponding fields.

NOTE. *If any of the above required fields are left blank, the settings will not be saved and email notifications will not be sent.*

5. In the Email Attachments section, select from the following options:
 - **Reports:** Select to receive the test report with the notification email.
 - **Status Log:** Select to receive the test status log with the notification email. If you select this option, then also select whether you want to receive the full log or just the last 20 lines.
6. In the Email Configuration section:
 - Select the message file format to send: HTML (the default) or plain text.
 - Enter a maximum file size for the email message. Messages with attachments larger than this limit will not be sent. The default is 5 MB.
 - Enter the number in the Number of Attempts to Send field, to limit the number of attempts that the system makes to send a notification. The default is 1. You can also specify a timeout period.
7. Select the **Email Test Results When complete or on error** check box. Use this check box to quickly enable or disable email notifications.
8. To test your email settings, click **Test Email**.
9. To apply your settings, click **Apply**.
10. Click **Close** when finished.

Email settings

Email Settings

Recipient e-mail Address(es)

Note: Separate Email addresses with a comma

Sender's Address

Email Attachments

Reports

ScoreCard

Analysis Screenshot

Status Log Last 20 Lines Full Log

Server Configuration

SMTP Server SMTP Port

Login

Password

Host Name

Email Configuration

Email Format HTML Plain Text

Max Email Size (MB)

Number of Attempts to Send

Timeout

Email Test Results When complete or on error

Test Em... Apply Close

Deskew

The Deskew utility reads the instrument configuration and channel deskew settings from the connected oscilloscope and stores them in a file. When you run a test (click the Start button), TekExpress 10G-KR resets the oscilloscope to the factory default settings, loads the instrument configuration and channel deskew settings with the saved values, and then starts running the test session. This is to make sure that the instrument is set to a known state before each test run.

NOTE. Make sure that you run the Deskew utility after you have finalized the DUT setup, oscilloscope settings, and channel deskew values, and before you run compliance tests with that test configuration. See your oscilloscope user documentation or online help for information on channel deskew procedures.

NOTE. You will need to run the Deskew utility whenever you change the oscilloscope settings or channel deskew values for a test setup.

NOTE. TekExpress 10G-KR does not verify that the saved oscilloscope settings and deskew values are applicable to the current instrument attached to the application.

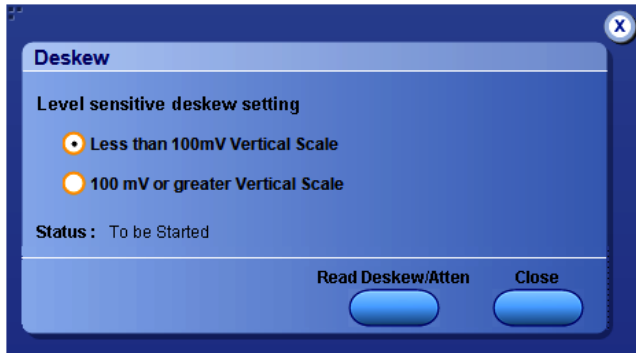

1. In the TekExpress Thunderbolt application, select **Options > Deskew**.
2. Select the level sensitive deskew setting:
 - **Less than 100 mV Vertical Scale**: Select this if the oscilloscope vertical setting is less than 100 mV/division for the signal you are measuring.
 - **100 mV or greater Vertical Scale**: Select this if the oscilloscope vertical setting is greater than 100 mV/division for the signal you are measuring.
3. Click **Read Deskew/Attn**. The utility stores the instrument settings and deskew settings as follows:
 - **<100 mV**: C:\Program Files\Tektronix\TekExpress\TekExpress 10G-KR\ICP\Deskew-Attenuation.txt
 - **≥100 mV**: C:\Program Files\Tektronix\TekExpress\TekExpress 10G-KR\ICP\Deskew-Attenuation-GE100mV.txt
4. When the status in the dialog box indicates the deskew is finished, click **Close**.

Application panel overview

Panels group related configuration, test, and results settings.

The TekExpress 10G-KR panels are:

Table 5: Application panels

Panel Name	Purpose
Setup (see page 21)	Set the DUT, test, acquisition, and report parameters. The Setup panel allows you to configure the test setup. Use this panel to: <ul style="list-style-type: none"> ■ Select device parameters (see page 22). ■ Select the test(s) (see page 25). ■ Select acquisitions parameters (see page 28) for selected tests. ■ Configure the selected tests (see page 30) ■ Select test notification preferences (see page 29).
Status (see page 33)	View the progress and analysis status of the selected tests, and view test logs.
Results (see page 35)	View a summary of test results and select result viewing preferences.
Reports (see page 37)	Browse for reports, save reports as specific file types, specify report naming conventions, select report content to include (such as summary information, detailed information, user comments, setup configuration, application configuration), and select report viewing options.

See also

[Application controls \(see page 14\)](#)
[about setting up tests \(see page 43\)](#)

Setup panel overview

The [Setup panel \(see page 22\)](#) contains sequentially ordered tabs that help guide you through a typical test setup process.

[Set the DUT parameters. \(see page 22\)](#)

[Select test\(s\). \(see page 25\)](#)

Set lane acquisition source.

[Select acquisitions \(see page 28\)](#)

[Configure tests \(see page 30\)](#)

[Select test notification preferences \(see page 29\)](#)

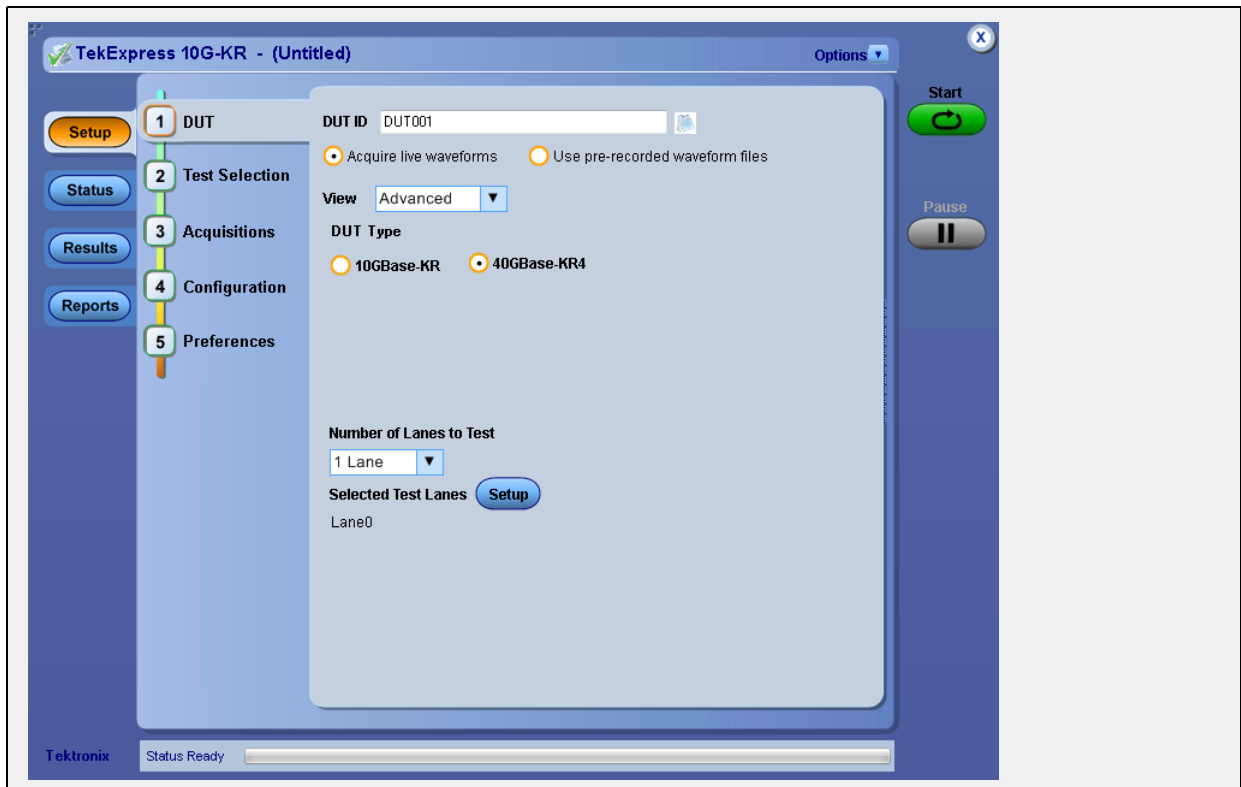

Set DUT parameters

Use the [Setup panel \(see page 22\)](#) DUT tab to select parameters for the device under test. The settings are global and apply to all tests for the current session. DUT settings also affect the list of available tests in the Test Selection tab.

1. Click **Setup > DUT**.
2. (Optional) Enter the ID for the device. The default value is DUT001. The DUT ID parameter is added to reports.
3. (Optional) To add comments to the test report, click the note pad icon () to the right of the DUT ID field. Enter comment text up to 256 characters. To enable or disable comments appearing on the test report, see [Select report options \(see page 38\)](#).)
4. Select from the following parameters. Settings that do not apply to compliance testing cannot be changed and are grayed out.

Table 6: DUT tab settings

Setting	Description
Acquire live waveforms	Acquire active signals from the oscilloscope for testing.
Use pre-recorded waveform files	Run tests on a saved run session file. Select a run session file from the list.
View	<p>Determines where to access the test configuration settings:</p> <ul style="list-style-type: none"> ■ Compliance: View configuration settings by clicking Setup > Test Selection > Configure ■ Advanced: Enables the Setup > Configuration tab in which to view configuration settings.
DUT Type	<p>Select the device type.</p> <ul style="list-style-type: none"> ■ 10GBase-KR: used for single lane devices ■ 40GBase-KR4: used for multilane devices (up to four lanes).

The following selections are displayed when the DUT Type is set to 40GBase-KR4.

Table 6: DUT tab settings (cont.)

Setting	Description
Number of Lanes to Test	Select the desired number of test lanes to use for this test session. The lanes shown here determines the number of test lanes you can select.
Selected Test Lanes	<p data-bbox="841 401 1341 428">Displays the test lanes selected for the test session.</p> <p data-bbox="841 438 1308 466">Click Setup to change lanes selected for testing.</p> <ol style="list-style-type: none"> <li data-bbox="889 491 1414 590">a. In the Test Lane Setup dialog box, select the desired number of lanes from the Link Width drop-down list. <li data-bbox="889 615 1403 1094">b. To select the lanes to use, click the corresponding lane buttons: <ul style="list-style-type: none"> <li data-bbox="938 701 1403 831">- To select both lanes at once, click Select All. If you select this, select 2 Lanes from the Number of Lanes to Test drop-down list. <li data-bbox="938 856 1403 919">- To deselect all selected lanes, click Deselect All. <li data-bbox="938 945 1357 1008">- If you select 1 Lane, select the Lane0 button. <li data-bbox="938 1033 1403 1094">- If you select 2 Lanes, select Lane0 and Lane1. <li data-bbox="889 1119 1062 1146">c. Click OK.

Your selections display in the Link Width section of the DUT tab.

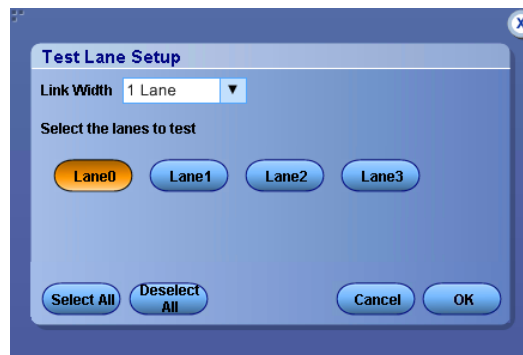

See also

- [About setting up tests \(see page 43\)](#)
- [Select a test \(see page 25\)](#)





Select tests

Use the Test Selection tab to select the tests to run on the connected DUT.

1. Click **Setup > Test Selection**.
2. Select the test(s) to run:
 - Click one or more check boxes adjacent to each test.
 - Click **Deselect All** to deselect all tests. All tests are selected by default.
 - Click **Select Required** to select all tests that are required for compliance.
 - Click **Select All** to select all tests.
 - To select an entire test group, select the check box for the test group; tests listed under the group are automatically selected.
 - To select one or more, but not all, tests in a test group, select only the check boxes for the desired tests.

Test selection controls

Table 7: Setup panel test controls

Button	Description
	When the View type selected in the DUT tab is Compliance, this button opens the configuration section for the selected test. If the View type is Advanced, this button is not displayed.
	Displays the schematic document for the selected test. Use to verify the test setup before running the test
	Deselects all tests in the table
	Selects tests required for compliance and deselects all other tests currently selected
	Selects all tests in the table

See also

- [Select acquisitions \(see page 28\)](#)
- [About setting up tests \(see page 43\)](#)

About acquisitions

Use the Acquisition tab in the Setup panel to view acquisition parameters for the tests. Options available on this tab depend on whether you selected to Acquire live waveforms or Use pre-recorded waveform files in the Setup > DUT tab.

When using pre-recorded waveform files, there are no acquisition selections to make. You can only select the source of the pre-recorded waveform file for each test.

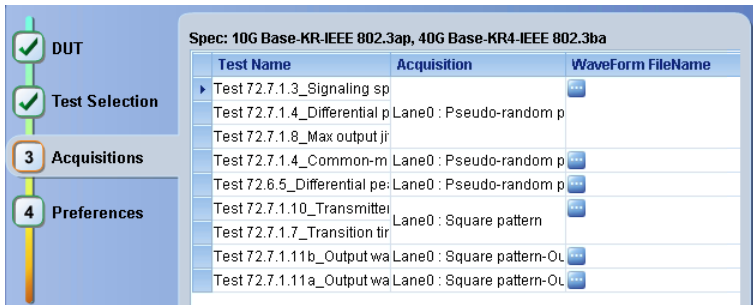

When acquiring live waveforms, the acquisition selections become available.

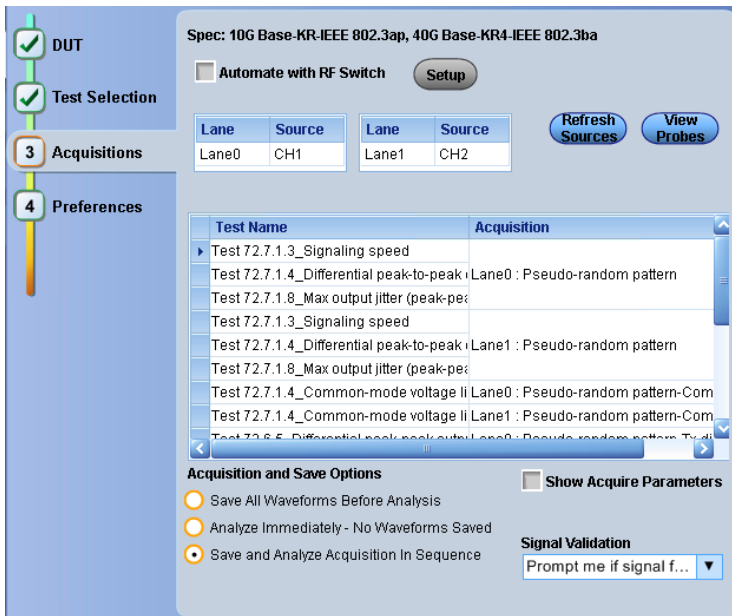

The top section of the Acquisitions tab is the source selection area. Here is where you assign the oscilloscope channels to the lanes.

The selections change depending on previous selections.

For example, The number of lanes displayed to assign to source channels changes depending on the Number of Lanes to Test selection made in the **Setup > DUT** tab.

If you are using an RF Switch setup, check the Automate with RF Switch check box. When checked, the lane assignments are removed and the RF Switch **Setup** button is enabled. Pressing the Setup button displays the [RF Switch setup \(see page 27\)](#) window. The RF Switch Setup allows you to map the lanes to the RF switch.

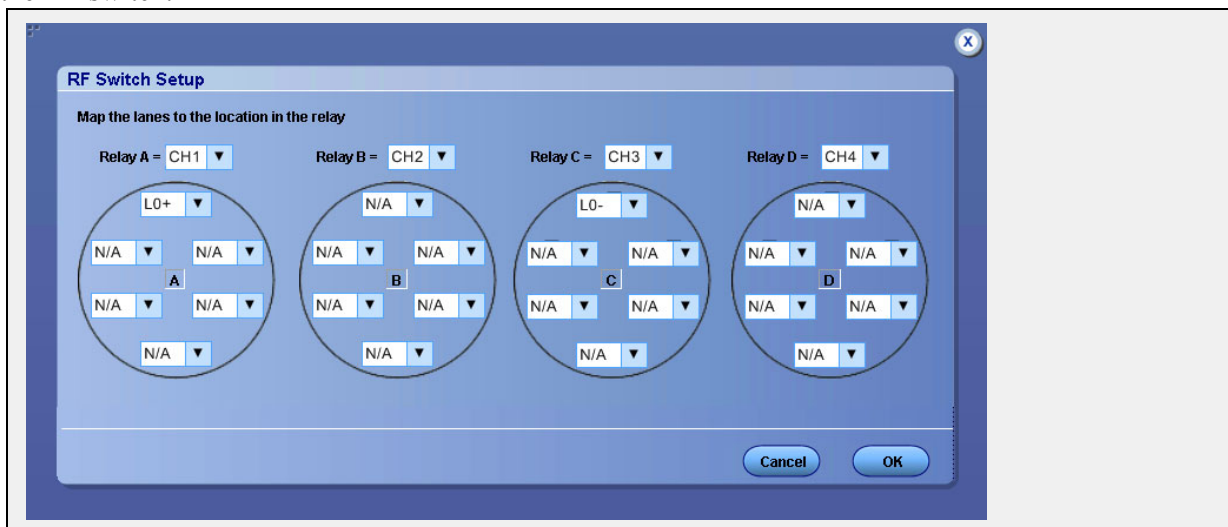

See also

[Set acquisition parameters source \(see page 28\)](#)

Set acquisition parameters source

Use the Acquisitions tab to set the signal source (channel) used to acquire data.

1. Click **Setup > Acquisitions**.
2. If you selected to use a pre-recorded waveform file, in the Acquisitions table, scroll to the Waveform FileName column. For each acquire type row, click the ellipsis button (⋮) and select the desired waveform file or files.
3. If you selected to use live waveforms and no RF switch automation, then the **Lane** and **Source** selection tables are displayed near the top of the tab. The number of Lane and Source selections displayed depend on whether testing a 10GBase-KR or 40GBase-KR interface and the number of lanes selected for testing in the **Setup > DUT** tab.
 - To see which probes are connected to which channels, click **View Probes**.
 - To refresh the probe configuration information displayed after changing any probes, click View Probes and then click Refresh in the Probe Configuration dialog box.
 - To change a lane source, click in the Source column and select a channel from the drop-down list.
 - Click the **Refresh Sources** button to refresh the probe configuration. (This button performs the same function as the Refresh button in the View Probes dialog box.)
4. If you selected to use live waveforms with RF switch automation (checked the Automate with RF Switch check box), the Setup button will become active and the Lane and Source selection tables are removed. Map the lanes to the relay locations.
 - a. Click the Setup button.
 - b. In the RF Switch Setup dialog box, map the lanes to the Relay locations and then click OK.
5. Select an **Acquisition and Save Options** to determine the order in which waveforms are acquired and analyzed.
 - Select **Save All Waveforms Before Analysis** to save all acquired waveforms before analysis begins.
 - Select **Analyze Immediately - No Waveform Saved** to perform an analysis without saving the waveform.
 - Select **Save and Analyze Acquisition in Sequence** to determine the order of acquisition and analysis during the test execution.
6. Select **Show Acquire Parameters** to show the acquisition parameters in the test list.

7. Select **Acquire Step By Step** to have the software prompt you to continue after each phase of the test completes.
8. Select a Signal Validation parameter:
 - Select **Prompt me if signal fails** to open a dialog box when the application fails to acquire a valid signal. Select one of the three options in the dialog box:
 - **Re-Acquire**: The application attempts to re-acquire the signal.
 - **Use Anyway**: Use the acquired signal for all applicable tests.
 - **Skip Test**: Skip (ignore) any test(s) that depend on this acquisition. Skipped tests are listed in the status panel and in the report.
 - Select **Skip test if signal fails** to automatically skip tests that use a particular signal if the signal validation fails. Skipped tests are listed in the status panel and in the report.
 - Select **Use signal as is - Don't Check** to skip signal validation and use the signal as-is for testing. The test results may not be as expected.

See also

[Select acquisitions \(see page 28\)](#)

[About setting up tests \(see page 43\)](#)

Set test notification preferences

Use the Preferences tab to set the application to send an email when a test measurement completes:

1. Click **Setup > Preferences**.
2. Select **Highlight yellow warning if measured value is within [xx]% of limit** check box to display a yellow warning if the measured value is within the percent of limit value.

If you select this option, enter the margin limit value.

3. Select the **On Test Failure, send me an email** check box to receive an email when a test fails.

If you select this option, select the **Email Test Results when complete or on error** check box in the **Email Settings** dialog box. Click **Email Settings** to [configure the email settings \(see page 17\)](#).

See also

[About setting up tests \(see page 43\)](#)

[Select report options \(see page 38\)](#)

About configuring test parameters

Use the configuration settings to view the measurement parameters for selected tests. How the test configurations are accessed depend on the View selected in the DUT tab.

- If you selected Compliance View in the DUT tab, then in the Test Selection tab, select the desired test in the list and then click the Configure button.
- If you selected Advanced View in the DUT tab, click the Configuration tab in the Setup panel.

See also

[Configure test parameters \(see page 30\)](#)

[About running tests \(see page 49\)](#)

Configure test parameters

The Configuration parameters let you set global and individual test parameters. To return to test selection from the Configuration tab or panel, click the Test Selection button.

NOTE. *You cannot change test parameters that are grayed out.*

1. Modify [Global settings \(see page 30\)](#) as desired:
 - To select the instruments for testing, click **Global Settings**. In the Instruments Detected section, click in the shaded areas to activate the drop-down lists and select an instrument. If you do not see the desired instrument in the list, [refresh the list \(see page 46\)](#).
2. To modify any individual test measurement settings, click **Measurements**, select the test in the tree view, and change the settings.

See also

[About setting up tests \(see page 43\)](#)

Common test parameters

The following table lists the settings and parameters common to all tests.

Table 8: Common parameters and values

Parameter Type	Parameter and Default Value
Mode	<p data-bbox="878 289 1438 348">Determines whether test parameters are in compliance or can be edited (User Defined Mode).</p> <ul style="list-style-type: none"> <li data-bbox="878 369 1422 428">■ Compliance: Most test parameter values cannot be edited. <li data-bbox="878 449 1406 506">■ User Defined: Most test parameter values can be edited.
Global Settings	<p data-bbox="878 527 1458 585">These settings apply to all tests selected for the current session. You can change only some of these settings.</p> <ul style="list-style-type: none"> <li data-bbox="878 606 1438 789">■ Instruments Detected: Displays a list of the connected instruments found during the instrument discovery. Instrument types include equipment such as oscilloscopes, signal generators, and RF switches. Select Options > Instrument Control Settings to refresh the list (see page 16). <li data-bbox="878 810 1458 869">■ Sample Rate: Specifies the oscilloscope sample rate to use for all tests. <li data-bbox="878 890 1458 1010">■ Pattern Type: The global pattern type specifies the pattern type to use for all applicable measurements unless a different pattern type is selected for a test in the Measurements tab. <li data-bbox="878 1031 1446 1089">■ Record Length: Specifies the length of the record (5M is the default) <li data-bbox="878 1110 1406 1169">■ Analyze without de-embedding filter: All tests are performed without a de-embedding filter. <li data-bbox="878 1190 1438 1289">■ Analyze with de-embedding filter: When selected, provides a browse button and field for selecting a filter to use to compensate for cable lengths. <li data-bbox="878 1310 1458 1463">■ Analyze with and without de-embedding filter: When selected, provides a browse button and field for selecting a filter to use to compensate for cable lengths. The tests are performed twice, with and without the filter. Results are provided for both cases for comparative analysis.

Table 8: Common parameters and values (cont.)

Parameter Type	Parameter and Default Value
Measurements	<p>Acquire:</p> <ul style="list-style-type: none"> Signal Type: Specifies the signal type of the acquisition for the test selected in the tree view of the Measurements tab. Running tests in User Defined Mode allows you to perform the tests on different types of signal. The default signal type varies by test. Not all tests support all the signal types. For each test, the application includes the signal type options that are best suited to the measurements
Limits Editor	<p>Shows the upper and lower limits for the applicable measurement using different types of comparisons.</p> <p>In Compliance Mode, allows you to view the measurement high and low limits used for the test selected in the tree view of the Measurements tab.</p> <p>When running tests in User Defined Mode, you can edit the limit settings in the Limits Editor.</p>

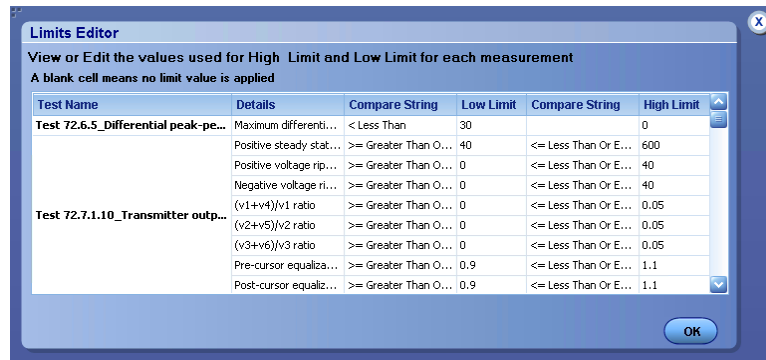

When running tests in User Defined Mode, the cells in the Limits Editor table are active for editing so you can change parameters.

See also

- [Configure tests \(see page 30\)](#)
- [Set acquisition parameters source \(see page 28\)](#)
- [De-embed using filter files \(see page 101\)](#)

Status panel overview

The Status panel provides status on test acquisition and analysis ([Test Status \(see page 33\)](#) tab) and a listing of test tasks performed ([Log View \(see page 34\)](#) tab). The application opens the Test Status tab when you start a test run. You can select the Test Status or the Log View tab to view these items while tests are running.

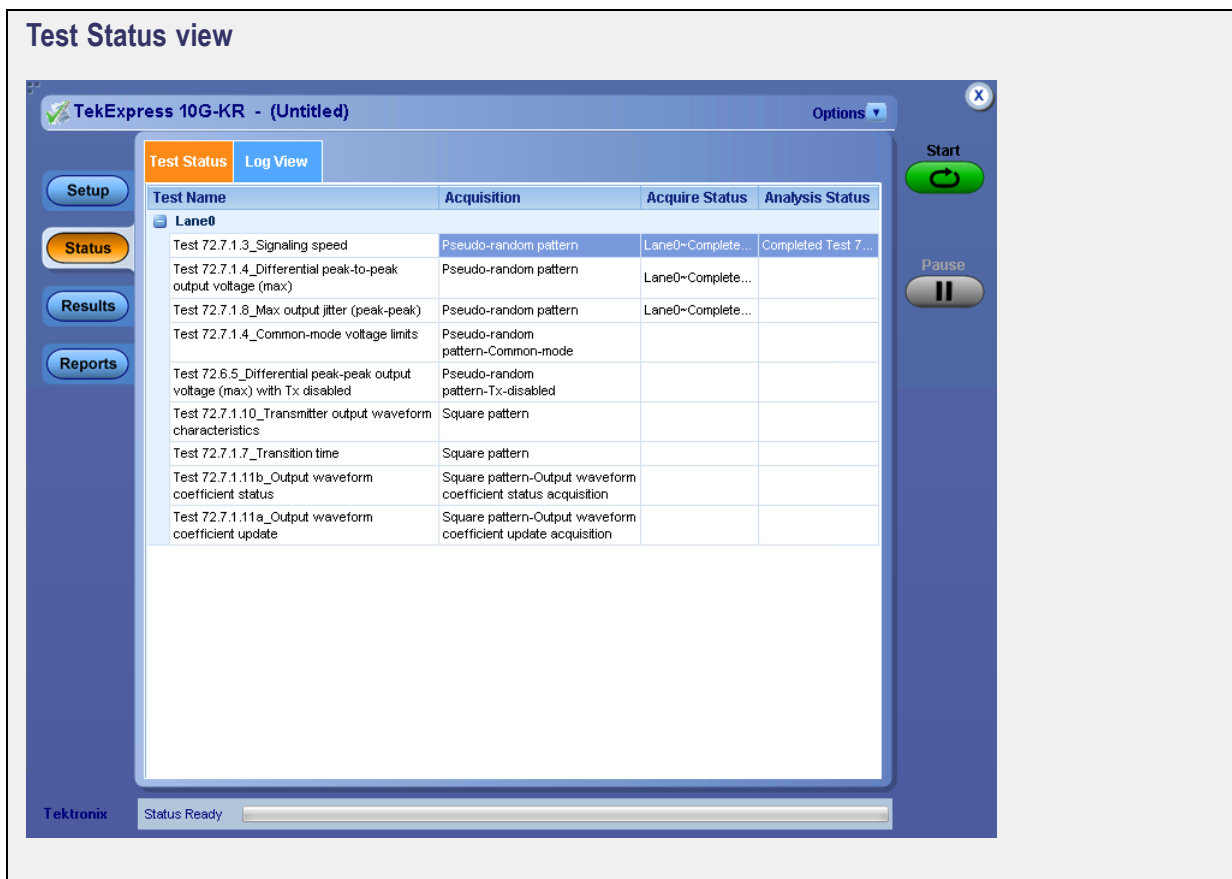

Log View

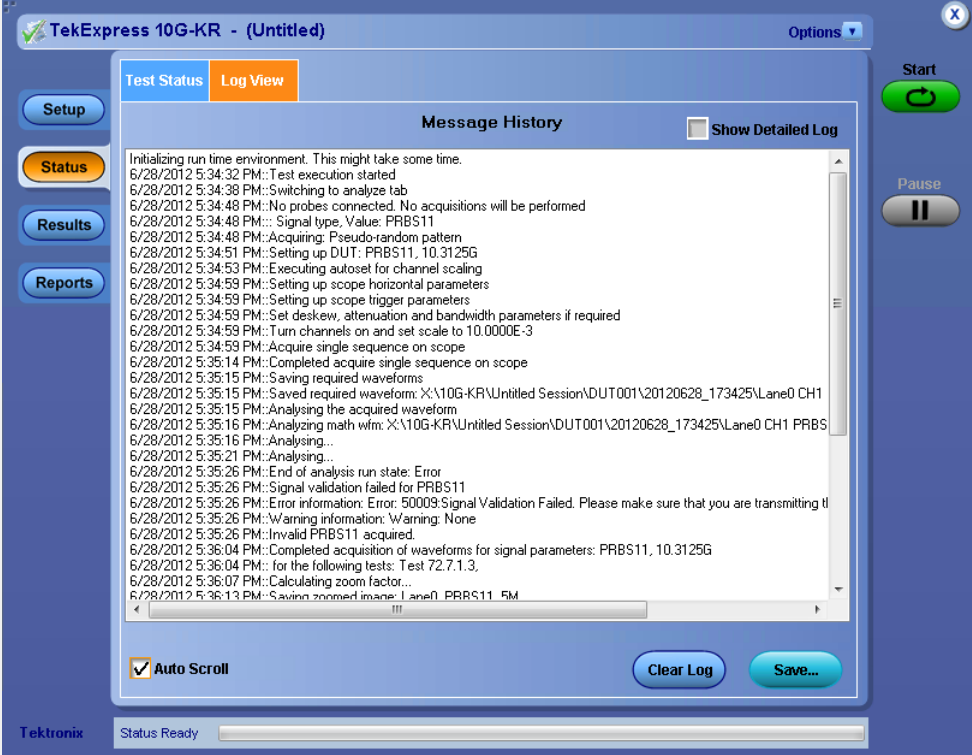

The Log View display has several viewing options:

- **Message History:** This window timestamps and displays all run messages.
- **Show Detailed Log:** Select this check box to record a detailed history of test execution. This must be checked before starting a measurement.
- **Auto Scroll:** Select this check box to have the program automatically scroll down as information is added to the log during the test.
- **Clear Log:** Click this button to clear all messages from the display.
- **Save:** Click this button to save the log file as a text file for examination. A standard Save File window is displayed to name and save the file.

See also

[Application panel overview \(see page 21\)](#)

Results panel overview

When a test finishes, the application switches to the [Results panel \(see page 35\)](#) to display a summary of test results.

Set viewing preferences for this panel from the Preferences menu in the upper right corner. Viewing preferences include showing whether a test passed or failed, summary results or detailed results, and enabling wordwrap.

For information on using this panel, see [View test results \(see page 36\)](#).

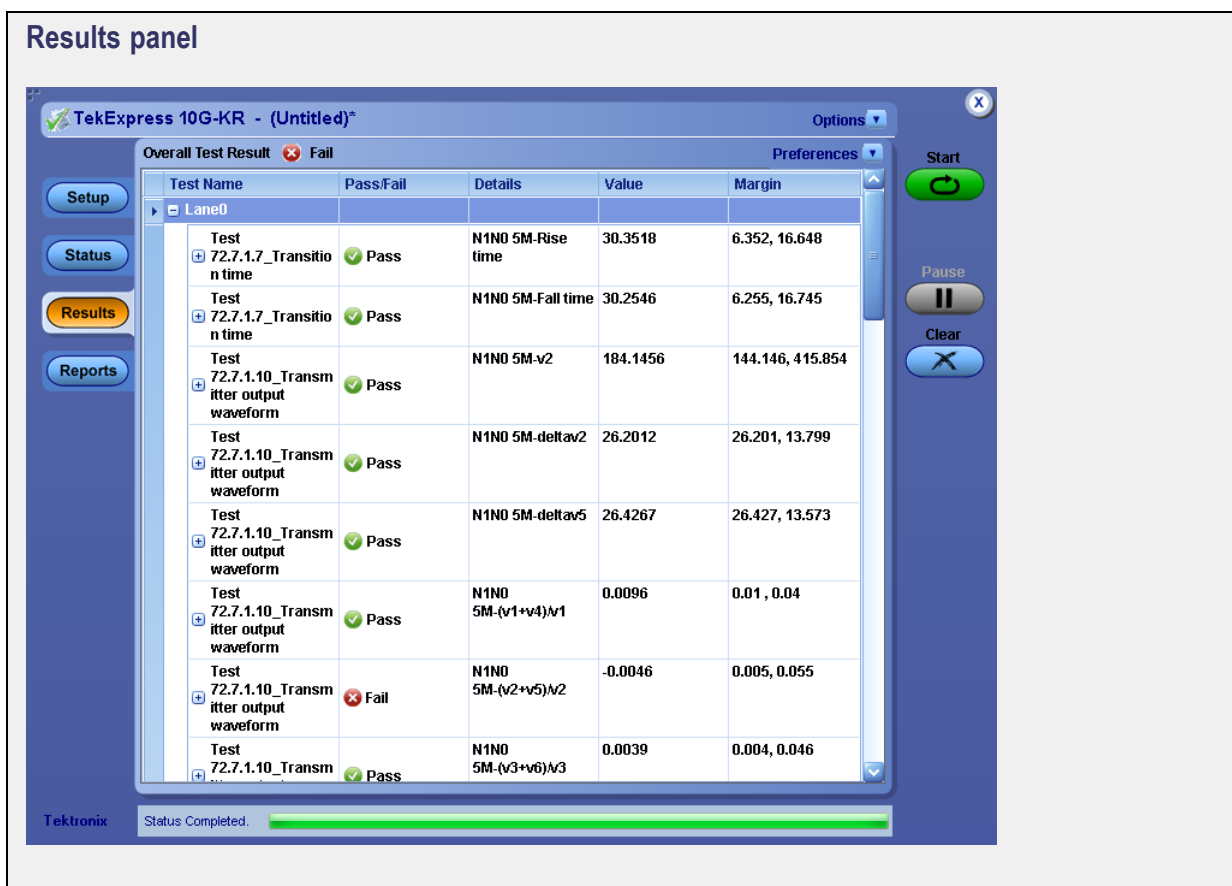

See also

[About panels \(see page 21\)](#)

View test results

When a test finishes, the application switches to the [Results panel \(see page 35\)](#), which displays a summary of test results. The Overall Test Result is displayed at the top left of the Results table. If all of the tests for the session pass, the overall test result will be Pass. If one or more tests fail, the overall test result will show Fail.

NOTE. *NAN (Not A Number) is displayed in the test results if an invalid waveform was supplied for the test.*

Each test result occupies a row in the Results table. By default, results are displayed in summary format with the measurement details collapsed and with the Pass/Fail column visible. Change the view in the following ways:

- To expand all tests listed, select **View Results Details** from the Preferences menu in the upper right corner.
- To expand and collapse tests, click the plus and minus buttons.
- To collapse all expanded tests, select **Preferences > View Results Summary**.
- To remove or restore the Pass/Fail column, select **Preferences > Show Pass/Fail**.
- To enable or disable the wordwrap feature, select **Preferences > Enable Wordwrap**.
- To expand the width of a column, place the cursor over the vertical line that separates the column from the column to the right. When the cursor changes to a double-ended arrow, hold down the mouse button and drag the column to the desired width.
- To sort the test information by column, click the column head. When sorted in ascending order, a small up arrow is displayed. When sorted in descending order, a small down arrow is displayed.
- To clear all test results displayed, click **Clear**.

See also

[View a report \(see page 40\)](#)

View test-related files

Files related to tests are stored in the `My TekExpress\10G-KR` folder. In the `10G-KR` folder, each test setup has a test setup file and a test setup folder, both with the test setup name:

The test setup file is preceded by the TekExpress icon and usually has no visible file extension.

Inside the test setup folder is another folder named for the DUT ID used in the test sessions. The default is `DUT001`.

Inside the `DUT001` folder are the session folders and files. Each session also has a folder and file pair, both named for the test session using the naming convention `(date)_(time)`. Each session file is stored outside its matching session folder:

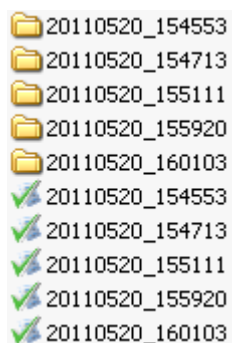

Each session folder contains image files of any plots generated from running the test session. If you selected to save all waveforms or ran tests using prerecorded waveform files, these are included here.

The first time you run a new, unsaved session, the session files are stored in the `Untitled Session` folder located at `.. \My TekExpress\10G-KR`. When you name and save the session, the files are placed in a folder with the name that you specify. A copy of the test files stay in the `Untitled Session` folder until you run a new test or until you close the `10G-KR` application.

See also

[File name extensions \(see page 12\)](#)

[Before you click start \(see page 49\)](#)

Reports panel overview

Use the [Reports panel \(see page 38\)](#) to browse for reports, name and save reports, select report content to include, and select report viewing options.

For information on setting up reports, see [Select report options \(see page 38\)](#). For information on viewing reports, see [View a Report \(see page 40\)](#).



See also

[About panels \(see page 21\)](#)

Select report options

Use the [Reports panel \(see page 37\)](#) to select which test information to include in the report, and the naming conventions to use for the report. For example, always give the report a unique name or select to have the same name increment each time you run a particular test. Generally, you would select report options before running a test or when creating and saving test setups. Report settings are included in saved test setups.

In the Reports panel, select from the following report options:

Table 9: Report options

Setting	Description
Report Name	<p>Displays the name and location from which to open a report. The default location is at <i>My TekExpress\10G-KR\Untitled Session</i>. The report file in this folder gets overwritten each time you run a test unless you specify a unique name or select to auto increment the report name.</p> <p>Change the report name or location.</p> <p>Do one of the following:</p> <ul style="list-style-type: none"> ■ In the Report Name field, type over the current folder path and name. ■ Double-click in the Report Name field and then make selections from the popup keyboard and click the Enter button. <p>Be sure to include the entire folder path, the file name, and the file extension. For example: C:\Documents and Settings\your user name\My Documents\My TekExpress\10G-KR\DUT001_Test_72.7.1.3.mht.</p> <p>NOTE. You cannot set the file location using the Browse button.</p> <p>Open an existing report.</p> <p>Click Browse, locate and select the report file and then click View at the bottom of the panel.</p>
Save As Type	<p>Saves a report in the specified file type. Lists supported file types to choose from.</p> <p>NOTE. If you select a file type different from the default, be sure to change the report file name extension in the Report Name field to match.</p>
Auto increment report name if duplicate	<p>Sets the application to automatically increment the name of the report file if the application finds a file with the same name as the one being generated. For example: DUT001, DUT002, DUT003. This option is enabled by default.</p>
Include Pass/Fail Results Summary	<p>Sets the application to include the color block labeled Test Result (indicating whether the test passed or failed) in the report. For details, see Report Contents in View a report (see page 40).</p>
Include Detailed Results	<p>Sets the application to include parameter limits, execution time, and test-specific comments generated during the test.</p>
Include Plot Images	<p>Screen shots captured from the oscilloscope during test execution that show the waveform and measurement data will be included.</p>

Table 9: Report options (cont.)

Setting	Description
Include Setup Configuration	Sets the application to include information about hardware and software used in the test in the summary box at the top of the report. Information includes: the oscilloscope model and serial number, probe model and serial number, the oscilloscope firmware version, SPC and factory calibration status, and software versions for applications used in the measurements.
Include Complete Application Configuration	Sets the application to include a table listing general, common, and acquired parameters used in the test. This option is disabled by default.
Include User Comments	Select to include any comments about the test that you or another user added in the DUT tab of the Setup panel. Comments appear in the Comments section under the summary box at the beginning of each report.
Append Reports	This option adds new report data to the end of an existing report of the same name. This option is disabled by default. This option is not available if the Auto Increment Report Name if Duplicate option is selected.
View Report After Generating	Automatically opens the report in your Web browser when the test completes. This option is selected by default.

See also

[View a report \(see page 40\)](#)

[About setting up tests \(see page 43\)](#)

View a report

The application automatically generates a report when test analysis is completed and displays the report in your default Web browser (unless you cleared the **View Report After Generating** check box in the Reports panel before running the test). If you cleared this check box, or if you want to view a different test report, do the following:

1. Click the **Browse > Reports** button and locate and select the report file to view.

NOTE. *If you did not save the test setup after running the report and you either closed the application or you ran another report, the report file was not saved.*

2. At the bottom of the Reports panel, click **View**.

For information on changing the file type, file name, and other report options, see [Select report options \(see page 38\)](#).

Report contents

A report shows specified test details, as defined in the Reports panel.

NOTE. *NAN (Not A Number) is displayed in the report contents if an invalid waveform was supplied for the test.*

Setup configuration information

Setup configuration information is listed in the summary box at the beginning of the report. This information includes the oscilloscope model and serial number, and software versions. To exclude this information from a report, clear the **Include Setup Configuration** check box in the Reports panel before running the test.

		TekExpress 10G-KR Detailed Report	
DUT ID: DUT001 Date/Time: July 03, 2012 / 11:52:23 CTS Version: CTS 0.9 Overall Compliance Mode: TRUE Overall Test Result: FAIL		Execution Time: 1 Hrs 3 Min	
Scope Model: DSA71604B Scope Serial Number: B110866 Probe Model (CH1): "TX" Probe Serial Number (CH1): "N/A" Probe Model (CH2): "NA" Probe Serial Number (CH2): "N/A" Probe Model (CH3): "TX" Probe Serial Number (CH3): "N/A" Probe Model (CH4): "N/A" Probe Serial Number (CH4): "N/A"		Scope F/W Version: 5.3.4 BUILD 25 SPC, Factory Calibration: PASS: PASS TekExpress Version (FW, App): Error : Version information missing in SRM.XML, DPOJET Version: "3.5.1 Build 4"	
Comments			

User comments

If you selected to include comments in the test report, any comments you added in the DUT tab of the Setup panel appear in the Comments section directly below the summary box.

Comments

Test result summary

The Test Result column indicates whether a test passed or failed. If the test passed, the column cell is green. If the test failed, it is red. To exclude this information from a report, clear the **Include Pass/Fail Results Summary** check box in the Reports panel before running the test.

Test Name	Pattern-Rec length	Lane	Measurement Details	Measured value	Units	Test Result	Margin
Test 72.7.1.3_Signaling speed	PRBS11 5M	Lane0	Speed	10.3122	Gbps	Pass	0.001, 0.001
Test 72.7.1.4_Differential peak-to-peak output voltage (max)	PRBS11 5M	Lane0	P2P-Tx enabled	663.0573	mV	Pass	536.943
			DCD	0.0042	UI	Pass	0.031
			Rj	0.0043	UI	Pass	0.146
			Dj	0.3015	UI	Fail	0.151
Test 72.7.1.8_Max output jitter (peak-peak)	PRBS11 5M	Lane0	TJBER	0.3405	UI	Fail	0.061
Test 72.7.1.4_Common-mode voltage limits	PRBS11 5M	Lane0	Common-mode P2P	94	mV	Pass	94 , 1806
Test 72.6.5_Differential peak-peak output voltage (max) with Tx disabled	PRBS11-Tx-disabled 5M	Lane0	P2P-Tx disabled	806	mV	Fail	776
Test 72.7.1.7_Transition time	N1N0 5M	Lane0	Rise time	33.2054	ps	Pass	9.205, 13.795
			Fall time	33.1235	ps	Pass	9.123, 13.877

See also

[View test results \(see page 36\)](#)

[View test-related files \(see page 37\)](#)

About setting up tests

Set up tests using the tabs in the [Setup panel \(see page 21\)](#). Settings in the DUT tab use a top-down, left-to-right logic flow, so that any parameter that affects or acts as a filter for other parameters appears either to the top of or to the left of the affected parameters.

Tests are saved when you save a test setup. To avoid overwriting test results, remember to assign a unique name to the test either before running it or immediately after.

See also

[Test setup overview \(see page 48\)](#)

[Before you click start \(see page 49\)](#)

[About test setups \(see page 53\)](#)

[About running tests \(see page 49\)](#)

Equipment connection setup

The following diagrams shows how to connect the DUT to the oscilloscope for the measurements.

Connection setup for differential tests

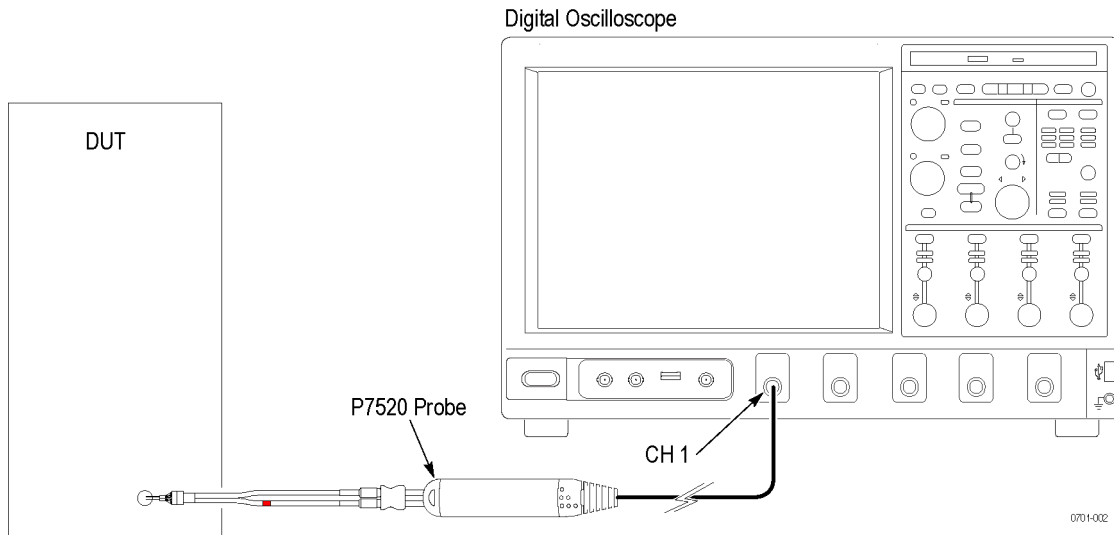

Connection setup for single ended tests

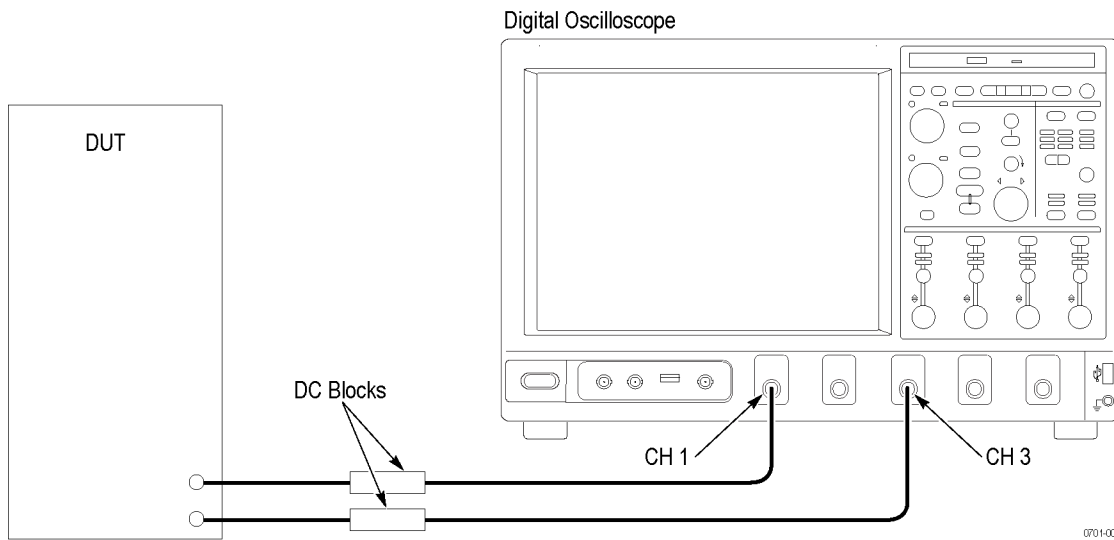

Connection setup for 40G-KR tests

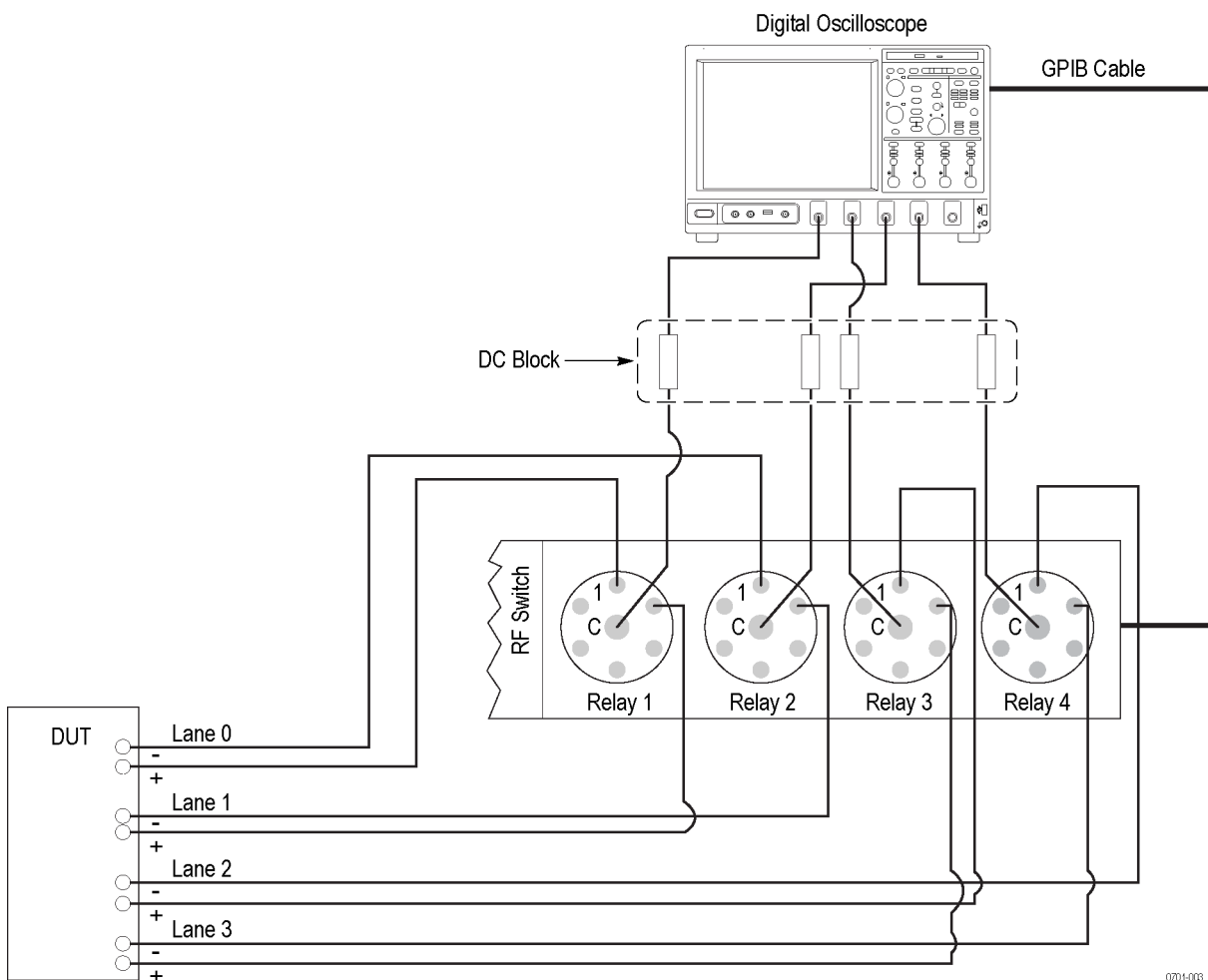

0701-003

See also

- [Minimum system requirements \(see page 8\)](#)
- [View connected instruments \(see page 46\)](#)
- [About setting up tests \(see page 43\)](#)

View connected instruments

Use the Instrument Control Settings dialog box to view or search for connected instruments required for the tests. The application uses TekVISA to discover the connected instruments.

To refresh the list of connected instruments:

1. From the Options menu, select **Instrument Control Settings**.
2. In the Search Criteria section of the Instrument Control Settings dialog box, select the connection types of the instruments to search for.

Instrument search is based on the VISA layer but different connected cables determine the resource type, such as LAN, GPIB, and USB. For example, if you choose LAN, the search will include all the instruments supported by TekExpress that are communicating over the LAN. If the search does not find any instruments that match a selected resource type, a message appears telling you that no such instruments were found.

3. Click **Refresh**. TekExpress searches for connected instruments.

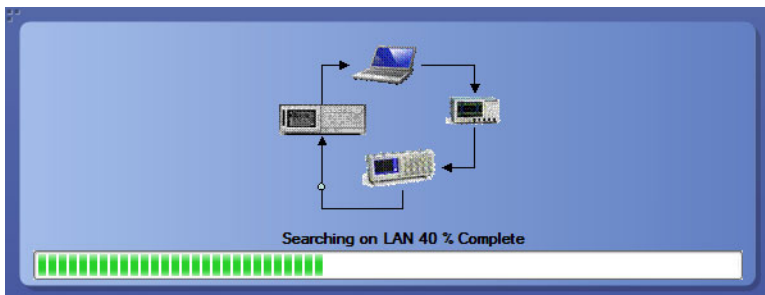

4. After discovery, the dialog box lists the instrument-related details based on the search criteria you selected. For example, if you selected LAN and GPIB as the search criteria, the application checks for the availability of instruments over LAN, then GPIB.

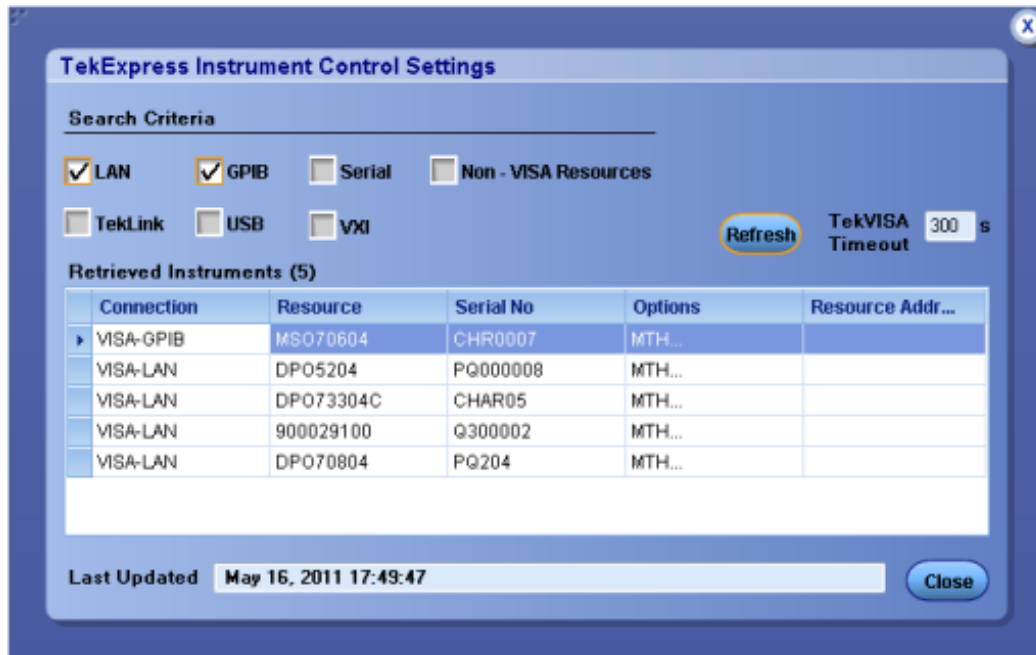

The details of the instruments are displayed in the Retrieved Instruments table. The time and date of instrument refresh is displayed in the Last Updated field.

See also

[Configure tests \(see page 30\)](#)

[Equipment connection setup \(see page 44\)](#)

Test setup overview

Test setup includes acquisition and configuration parameters, but you can also select report options when setting up tests. Use the options in the [Setup panel \(see page 21\)](#) and [Reports panel \(see page 37\)](#) to select and configure tests.

1. [Set DUT parameters \(see page 22\)](#).
2. [Select one or more tests \(see page 25\)](#).
3. [Select acquisitions \(see page 28\)](#).
4. [Configure tests \(see page 30\)](#).
5. [Set test measurement notification options \(see page 29\)](#).
6. [Select report options \(see page 38\)](#).

See also

[About test setups \(see page 53\)](#)

[Pre-run checklist \(see page 51\)](#)

[Before you click start \(see page 49\)](#)

[About running tests \(see page 49\)](#)

About running tests

After selecting and configuring tests, review the [pre-run checklist \(see page 51\)](#) and then click **Start** to run the tests. While tests are running, you cannot access the Setup or Reports panels. To monitor the test progress, switch back and forth between the Status panel and the Results panel.

The application displays a report when the tests are complete. While the tests are running, other applications may display windows in the background. The TekScope application takes precedence over other applications, but you can switch to other applications by using the Alt + Tab key combination. To keep the TekExpress 10G-KR application on top, select **Keep On Top** from the TekExpress Options menu.

See also

[Before you click start \(see page 49\)](#)

[About configuring tests \(see page 30\)](#)

[About setting up tests \(see page 43\)](#)

Before you click start

Before you run tests for the first time, do the following:

1. Understand where your test files are stored on the instrument.

After you install and launch TekExpress 10G-KR, it creates the following folders on the oscilloscope:

- \My Documents\My TekExpress\10G-KR
- \My Documents\My TekExpress\10G-KR\Untitled Session

Every time you launch TekExpress 10G-KR, an **Untitled Session** folder is created in the 10G-KR folder. The **Untitled Session** folder is automatically deleted when you exit the 10G-KR application. To preserve your test session files, save the test setup before exiting the TekExpress application.



CAUTION. Do not modify any of the session files or folders because this may result in loss of data or corrupted session files. Each session has multiple files associated with it. When you save a session, a .TekX file, and a folder named for the session that contains associated files, is created on the oscilloscope X: drive.

2. [Map the shared My TekExpress folder \(see page 107\)](#) as **X:** (X drive) on the instruments used in test setups running Microsoft Windows Operating System.

The My TekExpress folder has the share name format <domain><user ID>My TekExpress. Or, if the instrument is not connected to a domain, the share name format is <instrument name><user

ID>My TekExpress. This shared folder is used to save the waveform files and is used during other file transfer operations.

NOTE. If the X: drive is mapped to any other shared folder, the application will display a warning message asking you to disconnect the X: drive manually.

3. Make sure that the My TekExpress folder has read and write access, and that the contents are not set to be encrypted:
 - a. Right-click the folder and select **Properties**.
 - b. Select the **General** tab and then click **Advanced**.
 - c. In the Advanced Attributes dialog box, make sure that the option **Encrypt contents to secure data** is NOT selected. Example.

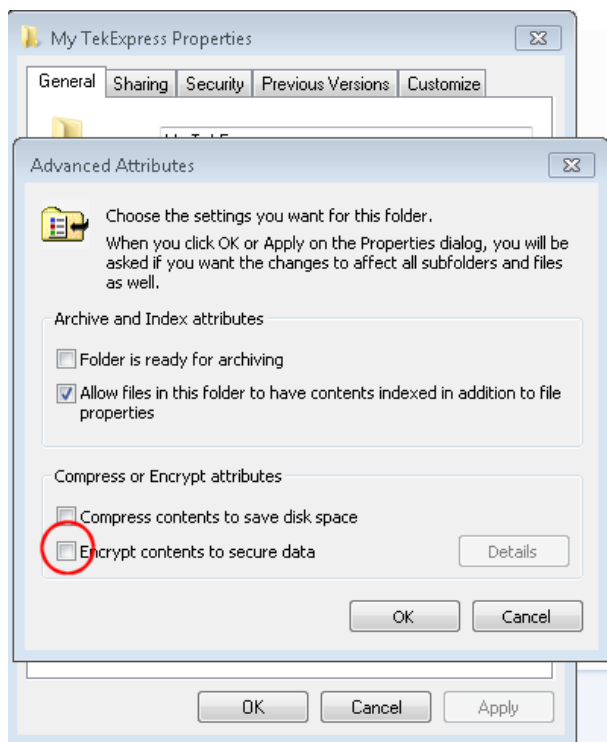

4. See the [pre-run checklist \(see page 51\)](#) before you run a test.

See also

[Configure tests \(see page 30\)](#)

[View test-related files \(see page 37\)](#)

[Application directories and usage \(see page 10\)](#)

[File name extensions \(see page 12\)](#)

Pre-run checklist

Do the following before you click Start to run a test. If this is the first time you are running a test on a setup, refer to the information in [Before you click start \(see page 49\)](#).

1. Make sure that all the required instruments are properly warmed up (approximately 20 minutes).
2. Perform Signal Path Compensation (SPC).
 - a. On the oscilloscope main menu, select the **Utilities** menu.
 - b. Select **Instrument Calibration**.
3. [Deskew channels \(see page 101\)](#).
4. Verify that the application is able to find the DUT. If it cannot, [perform a search for connected instruments \(see page 46\)](#).
 - a. In 10G-KR, select the **Setup** panel and then click the **Test Selection** tab.
 - b. Select any test and then click **Configure**.
 - c. In the Configuration section, click **Global Settings**.
 - d. In the Instruments Detected section, click the drop-down arrow to the right of Real Time Scope and make sure that the oscilloscope with the (GPIB8::1::INSTR) designation is in the list.

See also

[Equipment connection setup \(see page 44\)](#)

About test setups

TekExpress 10G-KR opens with the default setup selected. Run a test before or after saving a setup. When you save a setup, the test information, such as the selected oscilloscope, general parameters, acquisition parameters, measurement limits, waveforms (if applicable), and other configuration settings are all saved under the setup name. Use test setups to:

- Run a saved test in prerecorded mode.
- View all the information associated with a saved test, including the log file, the history of the test status as it executed, and the results summary.
- Create a new test setup based on an existing one.
- Run a new session, acquiring live waveforms, using a saved test configuration.

See also

[About setting up tests \(see page 43\)](#)

[Save a test setup \(see page 53\)](#)

[Recall a saved test setup \(see page 54\)](#)

Save a test setup

Save a test setup before or after running a test using the parameters you want saved. Create a new test setup from any open setup or from the default setup. When you select the default test setup, all parameters are returned to their defaults.

The following instructions start from the default test setup:

1. Select **Options > Default Test Setup**.
2. Select **Setup** and set required options and parameters in the tabs (DUT, Test Selection, and so on).
3. Select **Reports** and set your [report options \(see page 38\)](#).
4. Optional: Click **Start** to run the test and verify that it runs correctly and captures the information you want. If it does not, edit the parameters and repeat this step until the test runs to your satisfaction.

Running the test helps verify that all parameters are set correctly, but it is not a necessary step.

5. Select **Options > Save Test Setup**. Enter the file name for the setup file. The application saves the file to X:\10G-KR*<session_name>*.

See also

[About setting up tests \(see page 43\)](#)

[Test setup overview \(see page 48\)](#)

[View test-related files \(see page 37\)](#)
[About configuring tests \(see page 30\)](#)

Recall a saved test setup

These instructions are for recalling saved test setups.

1. Select **Options > Open Test Setup**.
2. Select the setup from the list and click **Open**.

See also

[About test setups \(see page 53\)](#)
[Create a new test setup based on an existing one \(see page 54\)](#)
[Test setups overview \(see page 48\)](#)

Create a new test setup based on an existing one

Use this method to create a variation on a test setup without having to create the setup from the beginning.

1. Select **Options > Open Test Setup**.
2. Select a setup from the list and then click **Open**.
3. Use the **Setup** and **Reports** panels to modify the parameters to meet your testing requirements.
4. Select **Options > Save Test Setup As**.
5. Enter a test setup name and click **Save**.

See also

[About test setups \(see page 53\)](#)
[Set DUT parameters \(see page 22\)](#)
[Configure tests \(see page 30\)](#)
[Select acquisitions \(see page 28\)](#)

About the programmatic interface

The Programmatic interface allows you to seamlessly integrate the TekExpress test automation application with the high-level automation layer. This also allows you to control the state of the TekExpress application running on a local or a remote computer.

For simplifying the descriptions, the following terminologies are used in this section:

- **TekExpress Client:** A high-level automation application that communicates with TekExpress using TekExpress Programmatic Interface.
- **TekExpress Server:** The TekExpress application when being controlled by TekExpress Client.

TekExpress leverages .Net Marshalling to enable the Programmatic Interface for TekExpress Client. TekExpress provides a client library for TekExpress clients to use the programmatic interface. The TekExpress client library is inherited from .Net MarshalByRef class to provide the proxy object for the clients. The TekExpress client library maintains a reference to the TekExpress Server and this reference allows the client to control the server state.

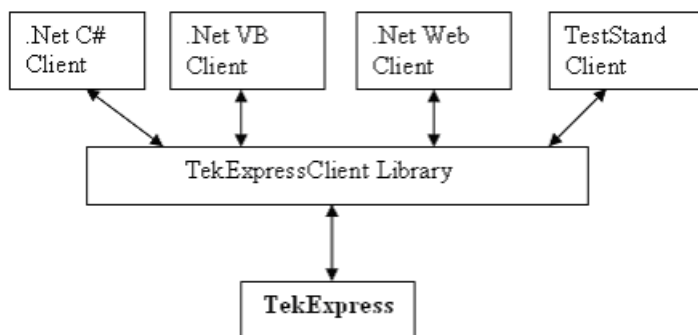

See also

[Requirements for Developing TekExpress Client \(see page 55\)](#)

Requirements for developing TekExpress client

While developing TekExpress Client, use the TekExpressClient.dll. The client can be a VB .Net, C# .Net, TestStand or Web application. The examples for interfaces in each of these applications are in the `Samples` folder.

References required

- `TekExpressClient.dll` has an internal reference to `IIdlgLib.dll` and `IRemoteInterface.dll`.
- `IIdlgLib.dll` has a reference to `TekDotNetLib.dll`.
- `IRemoteInterface.dll` provides the interfaces required to perform the remote automations. It is an interface that forms the communication line between the server and the client.
- `IIdlgLib.dll` provides the methods to generate and direct the secondary dialog messages at the client-end.

NOTE. *The end-user client application does not need any reference to the above mentioned DLL files. It is essential to have these DLLs (`IRemoteInterface.dll`, `IIdlgLib.dll` and `TekDotNetLib.dll`) in the same folder as that of `TekExpressClient.dll`.*

Required steps for a client

The client uses the following steps to use `TekExpressClient.dll` to programmatically control the server:

Develop a client UI to access the interfaces exposed through the server. This client loads `TekExpressClient.dll` to access the interfaces. After `TekExpressClient.dll` is loaded, the client UI can call the specific functions to run the operations requested by the client. When the client is up and running, it does the following to run a remote operation:

1. To connect to the server, the client provides the IP address of the PC where the server is running.
2. The client locks the server application to avoid conflict with any other Client that may try to control the server simultaneously. “Lock” would also disable all user controls on the server so that server state cannot be changed by manual operation.

If any other client tries to access a server that is locked, it will receive a notification that the server is locked by another client.

3. When the client has connected to and locked the server, the client can access any of the programmatic controls needed to run the remote automations.
4. After the client operations finish, the client unlocks the server.

See also

[About 10G-KR Application Commands \(see page 61\)](#)

Client programmatic interface example

An example of the client programmatic interface is described and shown as follows:

Process flowchart

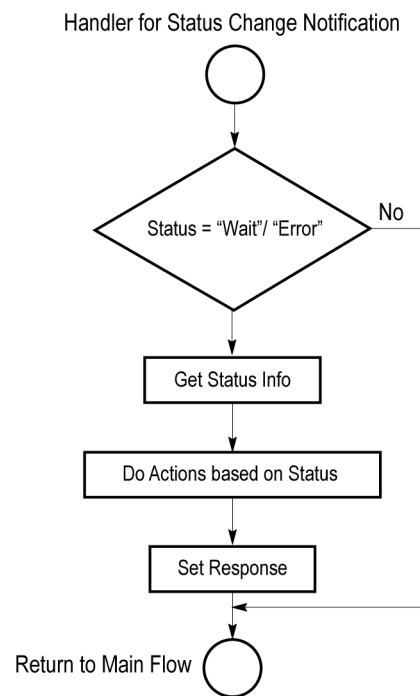
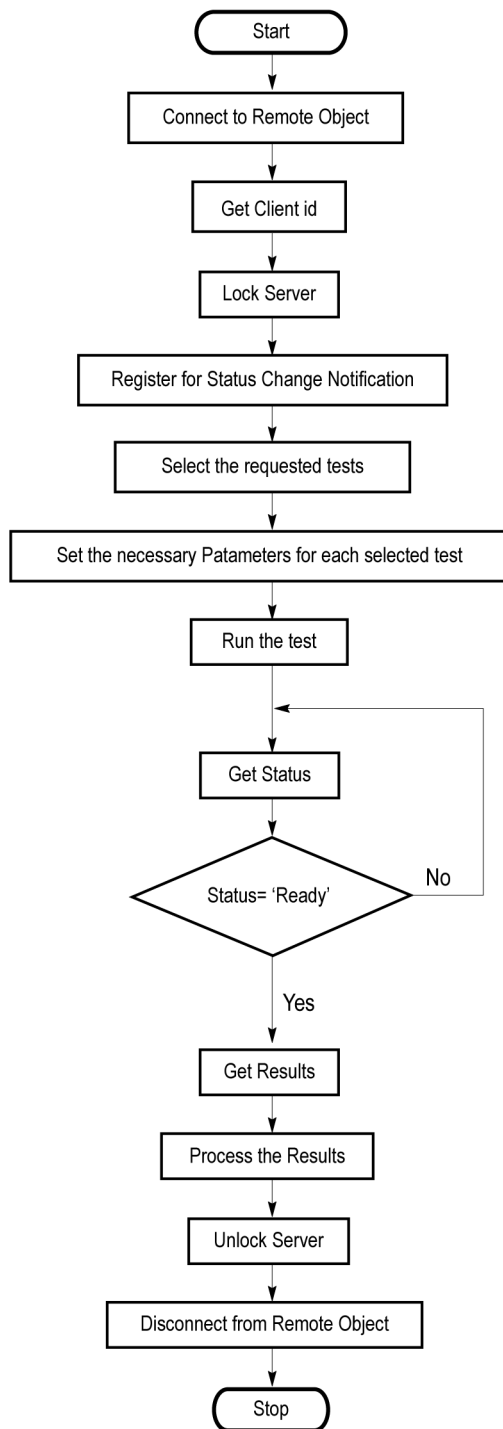

1. Connect to a server or remote object using the programmatic interface provided.
2. Get the client ID that is created when connecting to the remote object. This client ID is one of the required parameters to communicate with the server.

NOTE. *The server identifies the client with this ID only and rejects any request if the ID is invalid.*

3. Lock the server for further operations. This disables the application interface.

NOTE. *You can get values from the server or set values from the server to the client only if the application is locked.*

4. Register for receiving notifications on status change events on the server. To register you need to give a handler as a parameter.

NOTE. *Whenever there is a change in the status of the server, all the clients registered with the server receive a notification from the server.*

5. Select the tests that you want to run through the programmatic interface.
6. Set the necessary parameters for each test.
7. Run the tests.
8. Poll for the status of the application.

NOTE. *Skip step 8 if you are registered for the status change notification and the status is Ready.*

9. After completing the tests, get the results.
10. Create a report or display the results and verify or process the results.
11. Unlock the server after you complete all the tasks.
12. Disconnect from the remote object.

Handler of Status Change Notification

1. Get the status. If the status is Wait or Error, get the information that contains the title, message description, and the expected responses for the status.
2. Perform the actions based on the status information.
3. Set the response as expected.

See also

[About 10G-KR application commands \(see page 61\)](#)

[Program example \(see page 59\)](#)

Program example

This program example shows how to communicate between a PC and TekExpress 10G-KR remotely.

A typical application does the following:

1. Start the application.

2. Connect through an IP address.

```
m_Client.Connect("localhost") 'True or False
clientID = m_Client.getClientID
```

3. Lock the server.

```
m_Client.LockServer(clientID)
```

4. Disable the Popups.

```
m_Client.SetVerboseMode(clientID, false)
```

5. Set the Dut ID.

```
m_Client.SetDutId(clientID, "DUT_Name")
```

6. Select a measurement.

```
mClient.selectTest(clientID, "Device", "Source", "Test72.7.1.3_Signaling
speed", true) 'Measurement selected
```

7. Select a channel.

```
mClient.SetGeneralParameter(clientID, "Device", "Source",
"Test72.7.1.3_Signaling speed", "Lane0 Connected to:Lane0:Differen-
tial$CH1") 'Channel 1 selected for Lane 0
```

8. Configure the selected measurement.

```
mClient.SetAcquireParameter(clientID, "Device", "Source",
"Test72.7.1.3_Signaling speed", "Pseudo-random pattern$Signal type$PRBS7")
'Signal type of Signaling speed set to PRBS7
```

9. Run with set configurations.

```
m_Client.Run(clientID)
```

10. Wait for the test to complete.

```
Do
```

```
Thread.Sleep(500)
m_Client.Application_Status(clientID)
Select Case status
Case "wait"
'Get the Current State Information
m_Client.GetCurrentStateInfo(clientID, waitingMsBxCaption, waitingMsBxMes-
sage, waitingMsBxButtonTexts)
'Send the Response
m_Client.SendResponse(clientID, waitingMsBxCaption, waitingMsBxMessage,
waitingMsBxResponse)
End Select
Loop Until status = "Ready"
```

11. After the Test is Complete.

```
'Save all results values from folder for current run
m_Client.TransferResult(clientID, logDirname)
'Save all waveforms from folder for current run
m_Client.TransferWaveforms(clientID, logDirname)
'Save all images from folder for current run
m_Client.TransferImages(clientID, logDirname)
```

12. Unlock the server.

```
m_Client.UnlockServer(clientID)
```

13. Disconnect from server.

```
m_Client.Disconnect()
```

14. Exit the application.

NI TestStand client example

The following is an example for NI TestStand Client available in the path: C:\Program Files\Tektronix\TekExpress\TekExpress 10G-KR\Examples\Programmatic Interface\TestStand

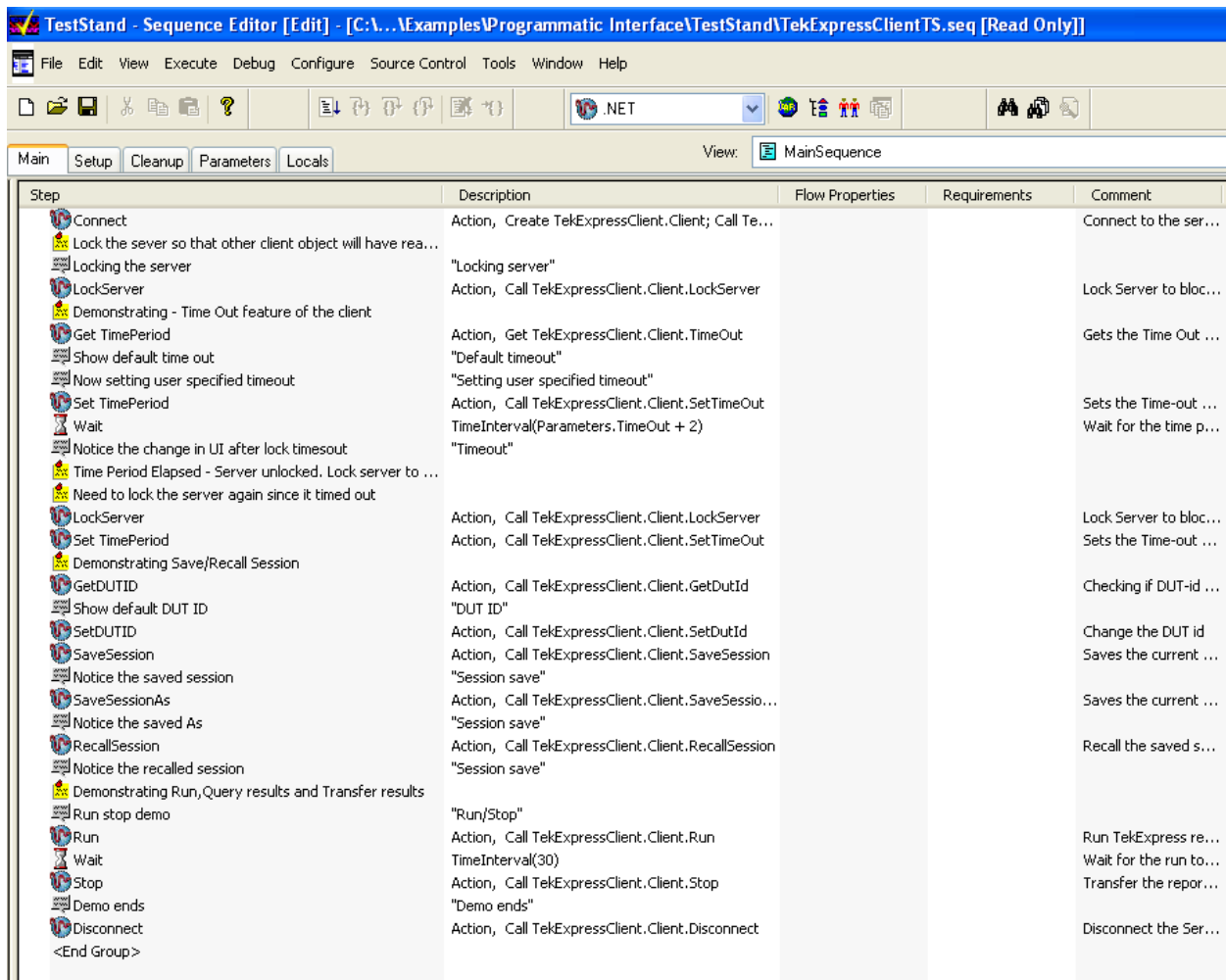

About 10G-KR application commands

Click a client action below to see the command name, description, parameters, return value, and an example, associated with the action.

[Connect through an IP address \(see page 68\)](#)

[Lock the server \(see page 69\)](#)

[Disable the popups \(see page 70\)](#)

[Set or get the DUT ID \(see page 71\)](#)

[Set the configuration parameters for a suite or measurement \(see page 72\)](#)

[Query the configuration parameters for a suite or measurement \(see page 74\)](#)

[Select a measurement \(see page 75\)](#)

[Select a suite \(see page 76\)](#)

[Select a channel \(see page 77\)](#)

[Configure the selected measurement \(see page 78\)](#)

[Run with set configurations or stop the run operation \(see page 79\)](#)

[Handle Error Codes \(see page 80\)](#)

[Get or set the timeout value \(see page 81\)](#)

[Wait for the test to complete \(see page 81\)](#)

[After the test is complete \(see page 84\)](#)

[Save, recall, or check if a session is saved \(see page 88\)](#)

[Unlock the server \(see page 89\)](#)

[Disconnect from server \(see page 90\)](#)

string id			
Name	Type	Direction	Description
id	string	IN	Identifier of the client performing the remote function.
<p>Ready: Test configured and ready to start</p> <p>Running: Test running</p> <p>Paused: Test paused</p> <p>Wait: A popup that needs your inputs</p> <p>Error: An error is occurred</p>			

string dutName			
Name	Type	Direction	Description
dutName	string	IN	The new DUT ID of the setup

out bool saved

Name	Type	Direction	Description
saved	bool	OUT	Boolean representing whether the current session is saved

This parameter is used as a check in SaveSession() and SaveSessionAs() functions.

string ipAddress

Name	Type	Direction	Description
ipAddress	string	IN	The ip address of the server to which the client is trying to connect to. This is required to establish the connection between the server and the client.

out string clientID

Name	Type	Direction	Description
clientid	string	OUT	Identifier of the client that is connected to the server clientid = unique number + ipaddress of the client. For example, 1065-192.157.98.70

NOTE. *If the dutName parameter is null, the client is prompted to provide a valid DUT ID.*

NOTE. *The server must be active and running for the client to connect to the server. Any number of clients can be connected to the server at a time.*

NOTE. *When the client is disconnected, it is unlocked from the server and then disconnected. The id is reused.*

string dutId

Name	Type	Direction	Description
dutId	string	OUT	The DUT ID of the setup

The dutId parameter is set after the server processes the request.

string device

Name	Type	Direction	Description
device	string	IN	Specifies the name of the device

string suite

Name	Type	Direction	Description
suite	string	IN	Specifies the name of the suite

string test

Name	Type	Direction	Description
test	string	IN	Specifies the name of the test to obtain the pass or fail status

string parameterString

Name	Type	Direction	Description
parameterString	string	IN	Selects or deselects a test

int rowNr

Name	Type	Direction	Description
rowNr	int	IN	Specifies the zero based row index of the sub-measurement for obtaining the result value

NOTE. When the client tries to lock a server that is locked by another client, the client gets a notification that the server is already locked and it must wait until the server is unlocked. If the client locks the server and is idle for a certain amount of time, then the server is unlocked automatically from that client.

out string[] status

Name	Type	Direction	Description
status	string array	OUT	The list of status messages generated during run

string name

Name	Type	Direction	Description
name	string	IN	The name of the session being recalled

The name parameter cannot be empty. If it is empty, the client is prompted to provide a valid name.

NOTE. *When the run is performed, the status of the run is updated periodically using a timer.*

string name

Name	Type	Direction	Description
name	string	IN	The name of the session being saved

The name parameter cannot be empty. If it is empty, the client is prompted to provide a valid name.

Once the session is saved under ‘name’ you cannot use this method to save the session in a different name. Use SaveSessionAs instead.

string name

Name	Type	Direction	Description
name	string	IN	The name of the session being recalled

The same session is saved under different names using this method. The name parameter cannot be empty. If it is empty, the client is prompted to provide a valid name.

bool isSelected

Name	Type	Direction	Description
isSelected	bool	IN	Selects or deselects a test

string time

Name	Type	Direction	Description
time	string	IN	The time in seconds which refers to the timeout period

The time parameter gives the timeout period, that is the time the client is allowed to be locked and idle. After the timeout period, if the client is still idle, it gets unlocked.

The time parameter should be a positive integer. Else, the client is prompted to provide a valid timeout period.

bool_verbose

Name	Type	Direction	Description
_verbose	bool	IN	Specifies whether the verbose mode should be turned ON or OFF

NOTE. When the session is stopped, the client is prompted to stop the session and is stopped at the consent.

string filePath

Name	Type	Direction	Description
filePath	string	IN	The location where the report must be saved in the client

NOTE. If the client does not provide the location to save the report, the report is saved at C:\ProgramFiles.

NOTE. When the client is disconnected, the client is unlocked automatically.

out string caption

Name	Type	Direction	Description
caption	string	OUT	The wait state or error state message sent to you

out string message			
Name	Type	Direction	Description
message	string	OUT	The wait state/error state message to you
out string[] buttonTexts			
Name	Type	Direction	Description
buttonTexts	string array	OUT	An array of strings containing the possible response types that you can send
string response			
Name	Type	Direction	Description
response	string	IN	A string containing the response type that can be selected (it must be one of the strings in the string array buttonTexts)

out string clientID			
Name	Type	Direction	Description
clientID	string	OUT	Identifier of the client that is connected to the server clientID = unique number + ipaddress of the client. For example, 1065-192.157.98.70

Connect through an IP address

Command name	Parameters	Description	Return Value	Example
Connect()	string ipAddress (see page 63) out string clientID (see page 63)	This method connects the client to the server. Note (see page 63) The client provides the IP address to connect to the server. The server provides a unique client identification number when connected to it.	Return value is either True or False.	<pre>m_Client = new Client() //m_Client is a reference to the Client class in the Client DLL. returnval as boolean returnval = m_Client.Connect(ipaddress,m_clientID)</pre>

NOTE. The Fail condition for PI commands occurs in any of the following cases:

The server is LOCKED and the message displayed is "Server is locked by another client".

The session is UNLOCKED and the message displayed is "Lock Session to execute the command".

The server is NOTFOUND and the message displayed is "Server not found...Disconnect!".

When none of these fail conditions occur, then the message displayed is "Failed...".

Lock the server

Command name	Parameters	Description	Return Value	Example
LockSession()	string clientID (see page 68)	<p>This method locks the server.</p> <p>Note (see page 64)</p> <p>The client must call this method before running any of the remote automations. The server can be locked by only one client.</p>	<p>String value that gives the status of the operation after it is performed.</p> <p>The return value is "Session Locked..." on success.</p>	<pre>m_Client = new Client() //m_Client is a reference to the Client class in the Client DLL. returnval as string returnval = m_Client.Lock- Server(clientID)</pre>

NOTE. *The Fail condition for PI commands occurs in any of the following cases:*

The server is LOCKED and the message displayed is "Server is locked by another client".

The session is UNLOCKED and the message displayed is "Lock Session to execute the command".

The server is NOTFOUND and the message displayed is "Server not found...Disconnect!".

When none of these fail conditions occur, then the message displayed is "Failed...".

Disable the popups

Command name	Parameters	Description	Return Value	Example
SetVerboseMode()	string clientID (see page 68) bool _verbose (see page 66)	This method sets the verbose mode to either true or false. When the value is set to true, any message boxes appearing during the application will be routed to the client machine that is controlling TekExpress. When the value is set to false, all the message boxes are shown on the server machine.	String that gives the status of the operation after it is performed When Verbose mode is set to true, the return value is "Verbose mode turned on. All dialog boxes will be shown to client". When Verbose mode is set to false, the return value is "Verbose mode turned off. All dialog boxes will be shown to server".	m_Client = new Client() //m_Client is a reference to the Client class in the Client DLL. returnval as string Verbose mode is turned on return=m_Client.SetVerboseMode(clientID, true) Verbose mode is turned off returnval=m_Client.SetVerboseMode(clientID, false)

NOTE. *The Fail condition for PI commands occurs in any of the following cases:*

The server is LOCKED and the message displayed is "Server is locked by another client".

The session is UNLOCKED and the message displayed is "Lock Session to execute the command".

The server is NOTFOUND and the message displayed is "Server not found...Disconnect!".

When none of these fail conditions occur, then the message displayed is "Failed...".

Set or get the DUT ID

Command name	Parameters	Description	Return Value	Example
SetDutId()	string clientID (see page 68) string dutName (see page 62)	This method changes the DUT ID of the set up. The client must provide a valid DUT ID.	String that gives the status of the operation after it is performed Return value is "DUT Id Changed" on success	m_Client = new Client() //m_Client is a reference to the Client class in the Client DLL. returnval as string return=m_Client.SetDutId(clientID,desiredDutId) Note (see page 63)
GetDutId()	string clientID (see page 68) string dutId (see page 64)	This method gets the DUT ID of the current set up.	String that gives the status of the operation after it is performed	m_Client = new Client() //m_Client is a reference to the Client class in the Client DLL. returnval as string re- turn=m_Client.GetDutid(clientID, out DutId)

NOTE. *The Fail condition for PI commands occurs in any of the following cases:*

The server is LOCKED and the message displayed is "Server is locked by another client".

The session is UNLOCKED and the message displayed is "Lock Session to execute the command".

The server is NOTFOUND and the message displayed is "Server not found...Disconnect!".

When none of these fail conditions occur, then the message displayed is "Failed...".

Set the Configuration Parameters for a suite or measurement

Command name	Parameters	Description	Return Value	Example
SetGeneralParameter	string clientID (see page 68) string device (see page 64) string suite (see page 64) string test (see page 64) string parameterString (see page 64)	This method sets the number of video lanes for the selected measurement. NOTE. Use this command to select a lane, channel, or source type.	String that gives the status of the operation after it is performed The return value is "" (an empty String) on success.	<pre>m_Client = new Client() //m_Client is a reference to the Client class in the Client DLL.</pre> returnval as string Select Channel (see page 73) Select Measurement Method (see page 73)
SetAnalyzeParameter()	string clientID (see page 68) string device (see page 64) string suite (see page 64) string test (see page 64) string parameterString (see page 64)	This method sets the configuration parameters in the Analyze panel of the Configuration Panel dialog box for a given suite or measurement.	The return value is "" (an empty String) on success.	<pre>m_Client = new Client() //m_Client is a reference to the Client class in the Client DLL.</pre> returnval as string
SetAcquireParameter()	string clientID (see page 68) string device (see page 64) string suite (see page 64) string test (see page 64) string parameterString (see page 64)	This method sets the configuration parameters in the Acquire panel of the Configuration Panel dialog box for a given suite or measurement.	<pre>returnVal = remoteObject.SetAcquireParameter(id, device, suite, test, parameterString) if ((OP_STATUS) returnVal != OP_STATUS.SUCCESS) return CommandFailed(returnVal)</pre>	

NOTE. The Fail condition for PI commands occurs in any of the following cases:

The server is LOCKED and the message displayed is "Server is locked by another client".

The session is UNLOCKED and the message displayed is "Lock Session to execute the command".

The server is NOTFOUND and the message displayed is "Server not found...Disconnect!".

When none of these fail conditions occur, then the message displayed is "Failed...".

Select channel example

```
returnval=mClient.SetGeneralParameter(clientID, "Device", "Source", "Test 72.7.1.3_Signaling speed", "Lane0 Connected to:Lane0:Differential$CH1")
```

Select measurement method example

```
returnval=mClient.SetGeneralParameter(clientID, "Device", "Source", "Test 72.7.1.3_Signaling speed", "Measurement Method$Automatic")
```

Configure analyze parameters example

Parameter	Example
Record Length	<pre>returnval = mClient.SetAcquireParameter(clientID, "Device", "Source", "Test 72.7.1.3_Signaling speed", "Record Length\$5M")</pre>

Query the Configuration Parameters for a suite or measurement

Command name	Parameters	Description	Return Value	Example
GetGeneralParameter()	string clientID (see page 68) string device (see page 64) string suite (see page 64) string test (see page 64) string parameterString (see page 64)	This method gets the general configuration parameters for a given suite or measurement.	The return value is the general configuration parameter for a given suite or measurement that is set.	m_Client = new Client() //m_Client is a reference to the Client class in the Client DLL. returnval as string Query Channel (see page 75) Query Measurement Method (see page 75)
GetAnalyzeParameter()	string clientID (see page 68) string device (see page 64) string suite (see page 64) string test (see page 64) string parameterString (see page 64)	This method gets the configuration parameters set in the Analyze tab of the Configuration Panel dialog box for a given suite or measurement.	The return value is the configuration parameter set in the Analyze tab of the Configuration Panel dialog box for a given suite or measurement.	m_Client = new Client() //m_Client is a reference to the Client class in the Client DLL. returnval as string
GetAcquireParameter()	string clientID (see page 68) string device (see page 64) string suite (see page 64) string test (see page 64) string parameterString (see page 64)	This method gets the configuration parameters set in the Acquire tab for a given suite or measurement.	The return value is the configuration parameter set in the Acquire tab for a given suite or measurement.	Query Acquire Parameters example (see page 75)

NOTE. The Fail condition for PI commands occurs in any of the following cases:

The server is LOCKED and the message displayed is "Server is locked by another client".

The session is UNLOCKED and the message displayed is "Lock Session to execute the command".

The server is NOTFOUND and the message displayed is "Server not found...Disconnect!".

When none of these fail conditions occur, then the message displayed is "Failed...".

Query channel example

```
returnval=mClient.GetGeneralParameter(clientID, "Device", "Source", "<Test/Measurement Name>", "Lane0 Connected to")
```

Query measurement method example

```
returnval=mClient.GetGeneralParameter(clientID, "Device", "Source", "<Test/Measurement Name>", "Measurement Method")
```

Query acquire parameter examples

Parameter	Example
Record Length	returnval = mClient.GetAcquireParameter(clientID, "Device", "Source", "Test72.7.1.3_Signaling speed", "Record Length\$5M")

Select a measurement

Command name	Parameters	Description	Return Value	Example
SelectTest()	string clientID (see page 68) string device (see page 64) string suite (see page 64) string test (see page 64) bool isSelected (see page 65)	<p>This method selects or deselects a given test.</p> <p>When this parameter is set to true, you can select a measurement.</p> <p>When this parameter is set to false, you can deselect a measurement.</p>	<p>String that displays the status of the operation after it is performed</p> <p>The return value is "" (an empty String) on success.</p>	<pre>m_Client = new Client() //m_Client is a reference to the Client DLL returnval as string Select Measurement (Test 72.7.1.3_Signaling speed): returnval=m_Client.SelectTest(clientID, "Device", "Source", "Test 72.7.1.3_Signaling speed", true)</pre>

NOTE. *The Fail condition for PI commands occurs in any of the following cases:*

The server is LOCKED and the message displayed is "Server is locked by another client".

The session is UNLOCKED and the message displayed is "Lock Session to execute the command".

The server is NOTFOUND and the message displayed is "Server not found...Disconnect!".

When none of these fail conditions occur, then the message displayed is "Failed...".

Select a suite

Command name	Parameters	Description	Return Value	Example
SelectSuite()	string clientID (see page 68) string device (see page 64) string suite (see page 64) bool isSelected (see page 65)	<p>This method selects or deselects a given suite.</p> <p>When this parameter is set to true, you can select a suite.</p> <p>When this parameter is set to false, you can deselect a suite.</p>	<p>String that gives the status of the operation after it is performed</p> <p>The return value is "" (an empty String) on success.</p>	<pre>m_Client = new Client() //m_Client is a reference to the Client class in the Client DLL. returnval as string Select Suite (Default): return-val=m_Client.SelectTest(clientID, "Device", "Source", true)</pre>

NOTE. The Fail condition for PI commands occurs in any of the following cases:

The server is LOCKED and the message displayed is "Server is locked by another client".

The session is UNLOCKED and the message displayed is "Lock Session to execute the command".

The server is NOTFOUND and the message displayed is "Server not found...Disconnect!".

When none of these fail conditions occur, then the message displayed is "Failed...".

Select a channel

Command name	Parameters	Description	Return Value	Example
SetGeneralParameter()	string clientID (see page 68) string device (see page 64) string suite (see page 64) string test (see page 64) string parameterString (see page 64)	This method sets the parameters that are not specific to any given test. NOTE. Use this command to select a lane, channel, or source type.	String that gives the status of the operation after it is performed The return value is "" (an empty String) on success.	<pre>m_Client = new Client() //m_Client is a reference to the Client class in the Client DLL. returnval as string Select Channel (see page 78) Select Measurement Method (see page 78)</pre>
SetAnalyzeParameter()	string clientID (see page 68) string device (see page 64) string suite (see page 64) string test (see page 64) string parameterString (see page 64)	This method sets the configuration parameters in the Analyze tab of the Configuration Panel dialog box for a given suite or measurement.	The return value is "" (an empty String) on success.	<pre>m_Client = new Client() //m_Client is a reference to the Client class in the Client DLL. returnval as string</pre>
SetAcquireParameter()	string clientID (see page 68) string device (see page 64) string suite (see page 64) string test (see page 64) string parameterString (see page 64)	This method sets the configuration parameters in the Acquire tab of the Configuration Panel dialog box for a given suite or measurement.	<pre>returnVal = remoteObject.SetAcquireParameter(id, device, suite, test, parameterString) if ((OP_STATUS) returnVal != OP_STATUS.SUCCESS) return CommandFailed(returnVal)</pre>	

NOTE. The Fail condition for PI commands occurs in any of the following cases:

The server is LOCKED and the message displayed is "Server is locked by another client".

The session is UNLOCKED and the message displayed is "Lock Session to execute the command".

The server is NOTFOUND and the message displayed is "Server not found...Disconnect!".

When none of these fail conditions occur, then the message displayed is "Failed...".

Select channel example

```
returnval=mClient.SetGeneralParameter(clientID, "Device", "Source", "Test 72.7.1.3_Signaling speed", "Lane0 Connected to:Lane0:Differential$CH1")
```

Select measurement method example

```
returnval=mClientSetGeneralParameter(clientID, "Device", "Source", "Test 72.7.1.3_Signaling speed", "Measurement Method$Automatic")
```

Configure the selected measurement

Command name	Parameters	Description	Return Value	Example
SetAnalyzeParameter()	string clientID (see page 68) string device (see page 64) string suite (see page 64) string test (see page 64) string parameterString (see page 64)	This method sets the Analyze parameters (Configuration parameters) for a given test.	The return value is "" (an empty String) on success.	m_Client = new Client() //m_Client is a reference to the Client class in the Client DLL. returnval as string
SetAcquireParameter()	string clientID (see page 68) string device (see page 64) string suite (see page 64) string test (see page 64) string parameterString (see page 64)	This method sets the Acquire parameters in the Acquire tab of the Configure Dialog box for a given test.	returnVal = remoteObject.SetAcquireParameter(id, device, suite, test, parameterString) if ((OP_STATUS) returnVal != OP_STATUS.SUCCESS) return CommandFailed(returnVal)	m_Client = new Client() //m_Client is a reference to the Client class in the Client DLL. returnval as string Configure Acquire Parameters for Record Length (see page 79)

NOTE. The Fail condition for PI commands occurs in any of the following cases:

The server is LOCKED and the message displayed is "Server is locked by another client".

The session is UNLOCKED and the message displayed is "Lock Session to execute the command".

The server is NOTFOUND and the message displayed is "Server not found...Disconnect!".

When none of these fail conditions occur, then the message displayed is "Failed...".

Configure parameter example

Parameter	Example
Record Length	returnval = mClient.SetAcquireParameter(clientID, "Device", "Source", "Test 72.7.1.3_Signaling speed", "Record Length\$5M")

Run with set configurations or stop the run operation

Command name	Parameters	Description	Return Value	Example
Run()	string clientID (see page 68)	Runs the selected tests. Note (see page 65) After the server is set up and configured, run it remotely using this function.	String that gives the status of the operation after it is performed The return value is "Run started..." on success.	m_Client = new Client() //m_Client is a reference to the Client class in the Client DLL. returnval as string returnval=m_Client.Run(clientID)
Stop()	string clientID (see page 68)	Stops the currently running tests Note (see page 66)	String that gives the status of the operation after it is performed. The return value is "Stopped..." on success.	m_Client = new Client() //m_Client is a reference to the Client class in the Client DLL. returnval as string returnval=m_Client.Stop(clientID)

NOTE. *The Fail condition for PI commands occurs in any of the following cases:*

The server is LOCKED and the message displayed is "Server is locked by another client".

The session is UNLOCKED and the message displayed is "Lock Session to execute the command".

The server is NOTFOUND and the message displayed is "Server not found...Disconnect!".

When none of these fail conditions occur, then the message displayed is "Failed...".

Handle error codes

The return value of the remote automations at the server-end is `OP_STATUS`, which changes to a string value depending on its code and returned to the client. The values of `OP_STATUS` are as follows:

Value	Code	Description
FAIL	-1	The operation failed.
SUCCESS	1	The operation succeeded.
NOTFOUND	2	Server not found
LOCKED	3	The server is locked by another client, so the operation cannot be performed.
UNLOCK	4	The server is not locked. Lock the server before performing the operation.
NULL	0	Nothing

Get or set the timeout value

Command name	Parameters	Description	Return Value	Example
GetTimeOut()	string clientID (see page 68)	Returns the current timeout period set by the client	String that gives the status of the operation after it is performed The default return value is 1800000.	m_Client = new Client() //m_Client is a reference to the Client class in the Client DLL. returnval as string return-val=m_Client.GetTimeOut()
SetTimeOut()	string clientID (see page 68) string time (see page 66)	Sets a timeout period specified by the client. After this timeout period expires, the server is unlocked automatically.	String that gives the status of the operation after it is performed On success the return value is "TimeOut Period Changed".	m_Client = new Client() //m_Client is a reference to the Client class in the Client DLL. returnval as string return-val=m_Client.SetTimeOut(clientID, desiredTimeOut)

NOTE. *The Fail condition for PI commands occurs in any of the following cases:*

The server is LOCKED and the message displayed is "Server is locked by another client".

The session is UNLOCKED and the message displayed is "Lock Session to execute the command".

The server is NOTFOUND and the message displayed is "Server not found...Disconnect!".

When none of these fail conditions occur, then the message displayed is "Failed...".

Wait for the test to complete

The commands in this group execute while tests are running. The GetCurrentStateInfo() and SendResponse() commands are executed when the application is running and in the wait state.

Command name	Parameters	Description	Return Value	Example
ApplicationStatus()	string clientID (see page 68)	This method gets the status of the server application. The states at a given time are Ready , Running , Paused , Wait , or Error . (see page 62)	String value that gives the status of the server application	<pre>m_Client = new Client() //m_Client is a reference to the Client class in the Client DLL. returnval as string returnval=m_Client.ApplicationStatus(clientID)</pre>
QueryStatus()	string clientID (see page 68) out string[] status (see page 65)	An interface for the user to transfer Analyze panel status messages from the server to the client.	String that gives the status of the operation after it is performed On success the return value is "Transferred..."	<pre>m_Client = new Client() //m_Client is a reference to the Client class in the Client DLL. returnval as string returnVal=m_Client.QueryStatus(clientID, out statusMessages) if ((OP_STATUS)returnVal == OP_STATUS.SUCCESS) return "Status updated..." else return CommandFailed(returnVal)</pre>

Command name	Parameters	Description	Return Value	Example
GetCurrentStateInfo() NOTE. This command is used when the application is running and is in the wait or error state.	string clientID (see page 68) out string caption (see page 66) out string message (see page 67) out string[] buttonTexts (see page 67)	This method gets the additional information of the states when the application is in Wait or Error state. Except client ID, all the others are Out parameters.	This command does not return any value. This function populates the Out parameters that are passed when invoking this function.	m_Client = new Client() //m_Client is a reference to the Client class in the Client DLL. m_Client.GetCurrentStateInfo(clientID, caption,message, buttonTexts)
SendResponse() NOTE. This command is used when the application is running and is in the wait or error state.	string clientID (see page 68) out string caption (see page 66) out string message (see page 67) string response (see page 67)	After receiving the additional information using the method GetCurrentStateInfo(), the client decides which response to send, and then sends the response to the application using this function. The response should be one of the strings that was received earlier as a string array in the GetCurrentStateInfo function. The _caption and _message should match the information received earlier in the GetCurrentStateInfo function.	This command does not return any value.	m_Client = new Client() //m_Client is a reference to the Client class in the Client DLL. m_Client.SendResponse(clientID, caption,message, response)

NOTE. The Fail condition for PI commands occurs in any of the following cases:

The server is LOCKED and the message displayed is "Server is locked by another client".

The session is UNLOCKED and the message displayed is "Lock Session to execute the command".

The server is NOTFOUND and the message displayed is "Server not found...Disconnect!".

When none of these fail conditions occur, then the message displayed is "Failed...".

After the test is complete

Command name	Parameters	Description	Return Value	Example
GetPassFailStatus()	string clientID (see page 68) string device (see page 64) string suite (see page 64) string test (see page 64)	This method gets the pass or fail status of the measurement after test completion. NOTE. <i>Execute this command after completing the measurement.</i>	String that gives the status of the operation after it is performed Returns the pass or fail status in the form of a string	<pre>m_Client = new Client() //m_Client is a reference to the Client class in the Client DLL. returnval as string returnval=m_Client.GetPassFailStatus(clientID, Device, Source, "Test 72.7.1.3_Signaling speed") //Pass or Fail</pre>
GetResultsValue()	string clientID (see page 68) string device (see page 64) string suite (see page 64) string test (see page 64) string parameterString (see page 64)	This method gets the result values of the measurement after the run.	String that gives the status of the operation after it is performed Returns the result value in the form of a string	<pre>m_Client = new Client() //m_Client is a reference to the Client class in the Client DLL. returnval as srting returnval=m_Client.GetResultsValue(clientID, "Device", "Source", "Test 72.7.1.3_Signaling speed", "Measured Value")</pre>

Command name	Parameters	Description	Return Value	Example
GetResultsValue- ForSubMeasure- ments()	string clientID (see page 68) string device (see page 64) string suite (see page 64) string test (see page 64) string parameterString (see page 64) int rowNr (see page 64)	This method gets the result values for individual sub-measurements after the run.	String that gives the status of the operation after it is performed Returns the result value in the form of a string	<pre>m_Client = new Client() //m_Client is a reference to the Client class in the Client DLL. returnval as string Test 72.7.1.3_Signaling speed return- val=m_Client.Ge- tResultsValue- ForSubMeasure- ments(clientID, "De- vice", "Source", "Test 72.7.1.8_Max output jitter (peak-peak)", "Measured Value",0) //For DCD measure- ment on Max output jitter (peak-peak) return- val=m_Client.Ge- tResultsValue- ForSubMeasure- ments(clientID, "De- vice", "Source", "Test 72.7.1.3_Signaling speed", "Measured Value", 1) //For DN wfm</pre>

Command name	Parameters	Description	Return Value	Example
GetReportParameter()	string clientID (see page 68) string device (see page 64) string suite (see page 64) string test (see page 64) string parameterString (see page 87)	<p>This method gets the general report details such as oscilloscope model, TekExpress version, and 10G-KR version.</p>	<p>The return value is the oscilloscope model, TekExpress version, and 10G-KR version.</p>	<pre>m_Client = new Client() //m_Client is a reference to the Client class in the Client DLL. returnval as string Oscilloscope Model return-val=m_Client.GetReportParameter(clientID,"Scope Model") TekExpress Version return-val=m_Client.GetReportParameter(clientID,"TekExpress Version") 10G-KR Version return-val=m_Client.GetReportParameter(clientID,"Application Version")</pre>
TransferReport()	string clientID (see page 68) string filePath (see page 66)	<p>This method transfers the report generated after the run.</p> <p>The report contains the summary of the run.</p> <p>The client must provide the location where the report is to be saved at the client-end.</p>	<p>String that gives the status of the operation after it is performed</p> <p>Transfers all the result values in the form of a string</p>	<pre>m_Client = new Client() //m_Client is a reference to the Client class in the Client DLL. returnval as string return-val=m_Client.TransferReport(clientID,"C:\Report")</pre>

Command name	Parameters	Description	Return Value	Example
TransferWaveforms()	string clientID (see page 68) string filePath (see page 66)	This method transfers all the waveforms from the folder for the current run. NOTE. <i>Each time you click Start, a folder is created on the X: drive. Transfer the waveforms before clicking Start..</i>	String that gives the status of the operation after it is performed Transfers all the waveforms in the form of a string On success the return value is "Transferred..."	m_Client = new Client() //m_Client is a reference to the Client class in the Client DLL. returnval as string return-val=m_Client.TransferWaveforms(clientID,"C:\Waveforms")
TransferImages()	string clientID (see page 68) od string filePath (see page 66)	This method transfers all the images (screen shots) from the folder for the current run (for a given suite or measurement). NOTE. <i>Each time you click Start, a folder is created in the X: drive. Transfer the waveforms before clicking Start.</i>	String that gives the status of the operation after it is performed Transfers all the images in the form of a string	m_Client = new Client() //m_Client is a reference to the Client class in the Client DLL. returnval as string return-val=m_Client.TransferImages(clientID,"C:\Waveforms")

NOTE. *The Fail condition for PI commands occurs in any of the following cases:*

The server is LOCKED and the message displayed is "Server is locked by another client".

The session is UNLOCKED and the message displayed is "Lock Session to execute the command".

The server is NOTFOUND and the message displayed is "Server not found...Disconnect!".

When none of these fail conditions occur, then the message displayed is "Failed...".

string parameterString			
Name	Type	Direction	Description
parameterString	string	IN	Specifies the oscilloscope model, TekExpress version, and 10G-KR version.

Save, recall, or check if a session is saved

Command name	Parameters	Description	Return Value	Example
CheckSession-Saved()	string clientID (see page 68) out bool saved (see page 63)	This method checks whether the current session is saved.	Return value is either True or False	m_Client = new Client() //m_Client is a reference to the Client class in the Client DLL. returnval as string returnval=m_Client.CheckSession-Saved(m_clientID, out savedStatus)
RecallSession()	string clientID (see page 68) string name (see page 65)	Recalls a saved session. The client provides the session name.	String that gives the status of the operation after it is performed The return value is "Session Recalled..."	m_Client = new Client() //m_Client is a reference to the Client class in the Client DLL. returnval as string returnval=m_Client.RecallSession(clientID, savedSessionName)
SaveSession()	string clientID (see page 68) string name (see page 65)	Saves the current session. The client provides the session name.	String that gives the status of the operation after it is performed The return value is "Session Saved..."/"Failed..."	m_Client = new Client() //m_Client is a reference to the Client class in the Client DLL. returnval as string returnval=m_Client.SaveSession(clientID, desiredSessionName)
SaveSessionAs()	string clientID (see page 68) string name (see page 65)	Saves the current session under a different name every time this method is called. The client provides the session name.	String that gives the status of the operation after it is performed The return value is "Session Saved..."	m_Client = new Client() //m_Client is a reference to the Client class in the Client DLL. returnval as string returnval=m_Client.SaveSessionAs(clientID, desiredSessionName)

NOTE. *The Fail condition for PI commands occurs in any of the following cases:*

The server is LOCKED and the message displayed is "Server is locked by another client".

The session is UNLOCKED and the message displayed is "Lock Session to execute the command".

The server is NOTFOUND and the message displayed is "Server not found...Disconnect!".

When none of these fail conditions occur, then the message displayed is "Failed...".

Unlock the server

Command name	Parameters	Description	Return Value	Example
UnlockSession()	string clientID (see page 68)	This method unlocks the server from the client. The ID of the client to be unlocked must be provided. Note (see page 66)	String that gives the status of the operation after it is performed The return value is "Session Un-Locked...".	m_Client = new Client() //m_Client is a reference to the Client class in the Client DLL. returnval as string return-val=m_Client.UnlockServer(clientID)

NOTE. *The Fail condition for PI commands occurs in any of the following cases:*

The server is LOCKED and the message displayed is "Server is locked by another client".

The session is UNLOCKED and the message displayed is "Lock Session to execute the command".

The server is NOTFOUND and the message displayed is "Server not found...Disconnect!".

When none of these fail conditions occur, then the message displayed is "Failed...".

Disconnect from the server

Command name	Parameters	Description	Return Value	Example
Disconnect()	string clientID (see page 68)	This method disconnects the client from the server. Note (see page 63)	Integer value that gives the status of the operation after it is performed 1 for Success -1 for Failure	m_Client = new Client() //m_Client is a reference to the Client class in the Client DLL. returnval as string return-val=m_Client.Disconnect(m_clientID)

NOTE. *The Fail condition for PI commands occurs in any of the following cases:*

The server is LOCKED and the message displayed is "Server is locked by another client".

The session is UNLOCKED and the message displayed is "Lock Session to execute the command".

The server is NOTFOUND and the message displayed is "Server not found...Disconnect!".

When none of these fail conditions occur, then the message displayed is "Failed...".

72.7.1.3 Signaling speed

Measures the signaling speed using the recommended PRBS11 signal. The 10GBASE-KR signaling speed shall be 10.3125 GBd \pm 100 ppm.

Measurement algorithm

TekExpress 10G-KR automatically executes the following measurements and calculations. This measurement is performed using DPOJET.

The input signal for this test is a PRBS11 waveform.

1. Compute the differential signal on Math1 = Dp - Dn.
2. Compute Period using DPOJET with Math1 as source.
3. The required result is 1/Period (mean).

See also

[Connection diagram for single ended tests \(see page 44\)](#)

[Connection diagram for differential tests \(see page 44\)](#)

72.7.1.4 Differential peak-to-peak output voltage (max)

Measures the differential peak-peak output voltage (max) using the recommended PRBS11 signal. The differential output voltage is constrained via the transmitter output waveform requirements specified in 72.7.1.10 of IEEE 802.3ap. The peak-to-peak differential output voltage shall be less than 1200 mV, regardless of equalization setting. The differential output voltage test pattern shall consist of at least eight symbols of alternating polarity.

Measurement algorithm

TekExpress 10G-KR automatically executes the following measurements and calculations. This measurement is performed as described below.

The input signal for this test is a differential PRBS11 waveform.

1. Identify the regions with the pattern 1010 or 0101 on the input signal.
2. Measure the high voltage and low voltage in that region.
3. The voltages corresponding to the signal high regions are taken as vHigh. The voltages corresponding to the signal low are taken as vLow. Compute the peak-to-peak (V_{pk-pk}) voltage by vHigh - vLow.
4. The V_{pk-pk} values are averaged across all regions (the required result for the differential peak to peak measurement).

See also

[Connection diagram for single ended tests \(see page 44\)](#)

[Connection diagram for differential tests \(see page 44\)](#)

72.6.5 Differential peak-to-peak output voltage (max) with Tx disabled

Measures the differential peak-peak output voltage (max) with Tx disabled. The differential output voltage is constrained via the transmitter output waveform requirements specified in 72.7.1.10 of IEEE 802.3ap. The peak-to-peak differential output voltage shall be less than 1200 mV, regardless of equalization setting. The transmitter output voltage shall be less than 30 mV peak-to-peak when disabled. The differential output voltage test pattern shall consist of no fewer than eight symbols of alternating polarity.

Measurement algorithm

TekExpress 10G-KR automatically executes the following measurements and calculations. This measurement is performed as described below.

The input signal for this test is a differential PRBS11, transmitter disabled, waveform.

1. Measure the high voltage and low voltage in the waveform.
2. The voltages corresponding to the signal high regions are taken as vHigh. The voltages corresponding to the signal low are taken as vLow. Compute the peak-to-peak (V_{pk-pk}) voltage by vHigh – vLow.

See also

[Connection diagram for single ended tests \(see page 44\)](#)

[Connection diagram for differential tests \(see page 44\)](#)

72.7.1.4 Common mode voltage limits

Measures the common mode voltage limits using the recommended PRBS11 signal. The common-mode voltage of SL(p) and SL(n) shall be between 0 V and 1.9 V with respect to signal ground.

Measurement algorithm

TekExpress 10G-KR automatically executes the following measurements and calculations. This measurement is made using the base oscilloscope measurement.

The input signal for this test is a differential PRBS11 waveform.

1. $\text{Math1} = (\text{Dp} + \text{Dn}) \div 2$. Switch off channels connected to Dp and Dn.
2. From the Measure menu, select Amplitude > Peak to Peak.
3. Select Math1 as the measurement source.
4. Do a single step run and measure the mean value of the histogram standard deviation. This is the measurement result.

See also

[Connection diagram for single ended tests \(see page 44\)](#)

[Connection diagram for differential tests \(see page 44\)](#)

72.7.1.7 Transition time

Measures the transition time (Rise time and Fall time) using the recommended N1N0 signal where N is between 8 and 11 (inclusive). The rising and falling edge transition times shall be between 24 ps and 47 ps as measured at the 20% and 80% levels referenced to v2 and v5 as defined in 72.7.1.11 of IEEE 802.3ap. The measurement is done using the square wave test pattern with no equalization and a run of at least eight consecutive ones and zeroes.

Measurement algorithm

TekExpress 10G-KR automatically executes the following measurements and calculations. This measurement is performed as described below.

The input signal for this test is a differential N1N0 (where N lies between 8 and 11, both inclusive) waveform.

1. Obtain the values of the upper limit (V2) and the lower limit (V5) from the Output Waveform Characteristics measurement.
2. Find the position of the rising and falling edges in the input waveform.
3. On each rising edge, traverse forward until the first point crossing the upper limit (80%) is found (=End) and traverse backward until the first point crossing the lower limit (20%) is found (= Start).
4. On each falling edge, traverse backward until the first point crossing the upper limit (80%) is found (=Start) and traverse forward until the first point crossing the lower limit (20%) is found (=End).
5. Compute the Transition Time, TT (= End – Start). This value is averaged across all edges.

See also

[Connection diagram for single ended tests \(see page 44\)](#)

[Connection diagram for differential tests \(see page 44\)](#)

72.7.1.8 Max output jitter (peak-peak)

Measures the Max output jitter (peak-peak) using the recommended PRBS11 signal.

Jitter components are measured along with their limits:

- Random jitter less than 0.15 UI (inclusive)

Random Jitter is the statistics for all timing errors not exhibiting deterministic behavior, based on the assumption that they follow a Gaussian distribution. Random Jitter is typically characterized by its standard deviation.

- Deterministic jitter less than 0.15 UI (inclusive)

Deterministic Jitter is the statistics for all timing errors that follow deterministic behavior. Deterministic Jitter is typically characterized by its peak-to-peak value.

- Duty cycle distortion less than 0.035 UI (inclusive)

Duty cycle distortion is the result of bit states that have different durations.

- Total jitter less than 0.28 UI (inclusive)

Total Jitter at a specified Bit Error Rate (BER). This combines the Random and Deterministic effects, and predicts a peak-to-peak jitter that will only be exceeded with a probability equal to the BER.

For the jitter measurement, the effect of a single-pole high-pass filter with a 3 dB point at 4 MHz is applied to the jitter. Crossing times are defined with respect to the mid-point (0 V) of the AC-coupled differential signal. Equalization is off during jitter testing.

Transmit jitter test requirements are specified in 72.7.1.9 of IEEE 802.3ap. The transmitter shall have a maximum total jitter of 0.28 UI peak-to-peak, composed of a maximum deterministic component of 0.15 UI peak-to-peak and a maximum random component of 0.15 UI peak-to-peak. Duty cycle distortion (DCD) is considered a component of deterministic jitter and shall not exceed 0.035 UI peak-to-peak. The peak-to-peak duty cycle distortion is defined as the absolute value of the difference in the mean pulse width of a 1 pulse or the mean pulse width of a 0 pulse (as measured at the mean of the high- and low-voltage levels in a clock-like repeating 0101 bit sequence) and the nominal pulse width.

Jitter specifications are specified for BER 10^{-12} .

Measurement algorithm (random jitter)

TekExpress 10G-KR automatically executes the following measurements and calculations. Measurements are made using the base oscilloscope measurements and DPOJET.

The input signal for this test is a differential PRBS11 waveform.

1. Deskew the Data+ and Data- inputs. Compute the differential signal on Math1 = Dp – Dn.
2. Use DPOJET measurement RJ (Jitter tab) on the Math signal.

Measurement algorithm (deterministic jitter)

TekExpress 10G-KR automatically executes the following measurements and calculations. Measurements are made using the base oscilloscope measurements and DPOJET.

The input signal for this test is a differential PRBS11 waveform.

1. Deskew the Data+ and Data- inputs. Compute the differential signal on Math1 = Dp – Dn.
2. Use DPOJET measurement RJ (Jitter tab) on the Math signal.

Measurement algorithm (duty cycle distortion)

TekExpress 10G-KR automatically executes the following measurements and calculations. This measurement is performed as described below.

The input signal for this test is a differential PRBS11 waveform.

1. Check if the input waveform pattern is a square wave test pattern.
2. If the input is a square wave test pattern, check for a number of continuous ones (between 8 and 11) in the test pattern.
3. Estimate the UI of the waveform (UI = bit duration). Identify the edges on the input waveform and the regions with the patterns 1010 or 0101.
4. Find the absolute value of the difference in the mean pulse width of a 1 pulse or the mean pulse width of a 0 pulse (from 1010 or 0101 patterns) and the nominal pulse width (estimated UI).

Measurement algorithm (total jitter)

TekExpress 10G-KR automatically executes the following measurements and calculations. Measurements are made using the base oscilloscope measurements and DPOJET.

The input signal for this test is a differential PRBS11 waveform.

1. Deskew the Data+ and Data- inputs. Compute the differential signal on Math1 = Dp – Dn.
2. Use DPOJET measurement TJ@BER (Jitter tab) on the Math signal.

See also

[Connection diagram for single ended tests \(see page 44\)](#)

[Connection diagram for differential tests \(see page 44\)](#)

72.7.1.10 Transmitter output waveform characteristics

Measures the output waveform characteristics using the recommended N1N0 signal where N is between 8 and 11 (inclusive).

The test pattern for the transmitter output waveform is the square wave test pattern defined in 52.9.1.2 of IEEE 802.3, with a run of at least eight consecutive ones. The transmitter output waveform test is based on the voltages v_1 through v_6 , Δv_2 , and Δv_5 , which shall be measured as shown in Figure 72–12 of IEEE 802.3ap.

Measurement algorithm

TekExpress 10G-KR automatically executes the following measurements and calculations. This measurement is performed as described below.

The input signal for this test is a differential PRBS11 waveform.

1. Check if the input waveform pattern is a square wave test pattern.
2. If the input is a square wave test pattern, check for a number of continuous ones (between 8 and 11) in the test pattern.
3. Determine if the starting edge is rising or falling. Depending on the result, measure the voltages v_1 , v_2 , v_3 , v_4 , v_5 , v_6 , and R_{pre} , R_{pst} according to the specification. Average the computed values across all the regions.
4. Compute R_{pre} and R_{pst} values from above computed voltages. $R_{pre} = v_3/v_2$, $R_{pst} = v_1/v_2$.
5. The values of v_2 and v_5 are considered as the upper and lower limits for transition time measurement.

See also

[Connection diagram for single ended tests \(see page 44\)](#)

[Connection diagram for differential tests \(see page 44\)](#)

72.7.1.11a Output waveform coefficient update

Measures the output waveform coefficient update and status using the recommended N1N0 signal where N is between 8 and 11 (inclusive).

The state of the transmitter equalizer and hence the transmitter output waveform is manipulated via the protocol defined in 72.6.10 of IEEE 802.3ap or via management. The changes in the transmitter output waveform resulting from coefficient update requests shall meet the requirements stated in Table 72–7 of IEEE 802.3ap. The coefficient update requests in Table 72–7 of IEEE 802.3ap are to be followed by a coefficient update equal to hold for all taps. The results shall be verified after the coefficient status for all taps is reported as not_updated. For any coefficient update, the magnitudes of the changes in v_1 , v_2 , and v_3 shall be within 5 mV of each other. When sufficient increment or decrement updates have been

applied to a given tap, it will reach a maximum or minimum limit governed by the coefficient range or by restrictions placed on minimum steady-state or maximum peak voltage, and the coefficient status is reported accordingly.

The transmitter output waveform shall meet the requirements of Table 72–8 of IEEE 802.3ap for all of the limiting cases represented in the table. Implementation of $c(-1)$ or $c(1)$ coefficient values greater than zero or less than the minimum defined by $R_{pre}(\min)$ and $R_{pst}(\min)$ is optional. A coefficient may be disabled by first asserting the preset control defined in IEEE 802.3 Table 45–55 and 45.2.1.78, then manipulating the other coefficients as required by the test.

Measurement algorithm

TekExpress 10G-KR automatically executes the following measurements and calculations. This measurement is performed as described below.

The input signal for this test is an N1N0 (where N lies between 8 and 11, both inclusive) waveform of the same pattern with different acquisitions captured at different states (1 through 6).

1. Check if each input waveform pattern is a square wave test pattern.
2. If the inputs are square wave test patterns, check for a number of continuous ones (between 8 and 11) in the test patterns.
3. Determine if the starting edge is rising or falling. Depending on the result, measure the voltages v_1 , v_2 , v_3 , v_4 , v_5 , v_6 , and R_{pre} , R_{pst} according to the specification. Average the computed values across all the regions.
4. Compute R_{pre} and R_{pst} values from above computed voltages. $R_{pre} = v_3/v_2$, $R_{pst} = v_1/v_2$ for all input waveforms.
5. Calculate $V_1(k)-V_1(k-1)$, $V_2(k)-V_2(k-1)$, $V_3(k)-V_3(k-1)$ for all input waveforms where K varies from 1 to 6.

See also

[Connection diagram for single ended tests \(see page 44\)](#)

[Connection diagram for differential tests \(see page 44\)](#)

72.7.1.11b Output waveform coefficient status

Measures the output waveform coefficient update and status using the recommended N1N0 signal where N is between 8 and 11 (inclusive).

The state of the transmitter equalizer and hence the transmitter output waveform is manipulated via the protocol defined in 72.6.10 of IEEE 802.3ap or via management. The changes in the transmitter output waveform resulting from coefficient update requests shall meet the requirements stated in Table 72–7 of IEEE 802.3ap. The coefficient update requests in Table 72–7 of IEEE 802.3ap are to be followed by a coefficient update equal to hold for all taps. The results shall be verified after the coefficient status for all taps is reported as not_updated. For any coefficient update, the magnitudes of the changes in v1, v2, and v3 shall be within 5 mV of each other. When sufficient increment or decrement updates have been applied to a given tap, it will reach a maximum or minimum limit governed by the coefficient range or by restrictions placed on minimum steady-state or maximum peak voltage, and the coefficient status is reported accordingly.

The transmitter output waveform shall meet the requirements of Table 72–8 of IEEE 802.3ap for all of the limiting cases represented in the table. Implementation of c(–1) or c(1) coefficient values greater than zero or less than the minimum defined by Rpre (min) and Rpst (min) is optional. A coefficient may be disabled by first asserting the preset control defined in IEEE 802.3 Table 45–55 and 45.2.1.78, then manipulating the other coefficients as required by the test.

Measurement algorithm

TekExpress 10G-KR automatically executes the following measurements and calculations. This measurement is performed as described below.

The input signal for this test is an N1N0 (where N lies between 8 and 11, both inclusive) waveform of same pattern with different acquisitions captured at different states (1 though 4).

1. Check if each input waveform pattern is a square wave test pattern.
2. If the inputs are square wave test patterns, check for a number of continuous ones (between 8 and 11) in the test patterns.
3. Determine if the starting edge is rising or falling. Depending on the result, measure the voltages v1, v2, v3, v4, v5, v6, and Rpre, Rpst according to the specification. Average the computed values across all the regions.
4. Compute Rpre and Rpst values from above computed voltages. $Rpre = v3/v2$, $Rpst = v1/v2$ for all input waveforms.

See also

[Connection diagram for single ended tests \(see page 44\)](#)

[Connection diagram for differential tests \(see page 44\)](#)

De-embed using filter files

TekExpress 10G-KR provides an option to de-embed the signal path using filter files. You create the filter files. The filter files are .flt files composed of de-embed filter coefficients for a particular sampling rate. A filter file created for one sampling rate might not work for other sampling rates, so it is important to understand at what sampling rate the measurements are being performed.

Also, the de-embedding filters might differ based on the type of input. For example, if a single ended input is made via a matched SMA cable pair, a filter file for de-embedding a single SMA cable needs to be provided, since matched SMA cables mostly have similar s-parameters. So in this case, the same filter file would be used for de-embedding the SMA cable pair.

The maximum sampling rate provided on any channel combination on MSO/DPO/DSA70000 A and B series oscilloscopes is 50 GS/s in realtime mode. The maximum sampling rate provided on Ch1-Ch3 and Ch2-Ch4 channel combinations on MSO/DPO/DSA70000 C and D series oscilloscopes is 100 GS/s, provided only 2 channels are switched on at a given time.

See also

[Common test parameters and values \(see page 30\)](#)

[Configure tests \(see page 30\)](#)

Deskew channels

If skew is present between positive and negative channels, then the channels need to be deskewed before being used for waveform measurements. TekExpress 10G-KR provides support for channel deskew using the following method:

1. Determine what the skew is for each channel.
2. From the TekScope menu, select **Vertical** > **Deskew**.
3. In the Deskew/Attenuation window, click the channel (1 – 4) button for the first channel to be deskewed.
4. Click in the Ch(x) Deskew Time entry field and enter the skew. The skew can be +ve or –ve.
5. Click the channel button for the next channel and repeat step 4.
6. After entering the skew for all the channels that require it, from the Options menu in TekExpress 10G-KR, select **Deskew**.

7. In the Deskew dialog box, select the desired level:
 - **Less than 100 mV signal amplitude:** Select this if the signal amplitude is such that the oscilloscope's vertical setting is less than 100 mV/division.
 - **100 mV or greater signal amplitude:** Select this if the signal amplitude is such that the oscilloscope's vertical setting is greater than 100 mV/division.
8. Click **Read Deskew/Attn**.
9. When the status in the dialog box indicates the deskew is finished, click **Close**.

Each input channel has its own deskew settings. Deskew compensates individual channels for probes or cables of different lengths. The instrument applies the delay values after each completed acquisition. The deskew values are saved as part of the instrument setup. The deskew values for the selected channel are retained until you change the probe, you restore a saved setup, or you recall the factory setup.

See also

[Select acquisitions \(see page 28\)](#)

[Prerun checklist \(see page 51\)](#)

DPOJET option 10G-KR plug-in

The TekExpress 10G-KR installation process allows you to also install the 10G-KR option plug-in to the TekScope DPOJET application.

By installing this plug-in, you'll be able to use the DPOJET analysis tools that will allow you much greater flexibility to make changes to the 10G-KR tests and explore other configurations to help you in your particular test environment.

If the 10G-KR DPOJET plug-in is installed, the 10G-KR is added to the plug-in section of the [TekScope Analyze menu \(see page 103\)](#) and the standard is added to the DPOJET Jitter and Eye Diagram Analysis Tools. Selecting the 10G-KR plug-in option launches DPOJET and displays the Standard menu. The [TekScope Help menu \(see page 104\)](#) is also updated to include the help topic 10G-KR MOI (Methods of Implementation).

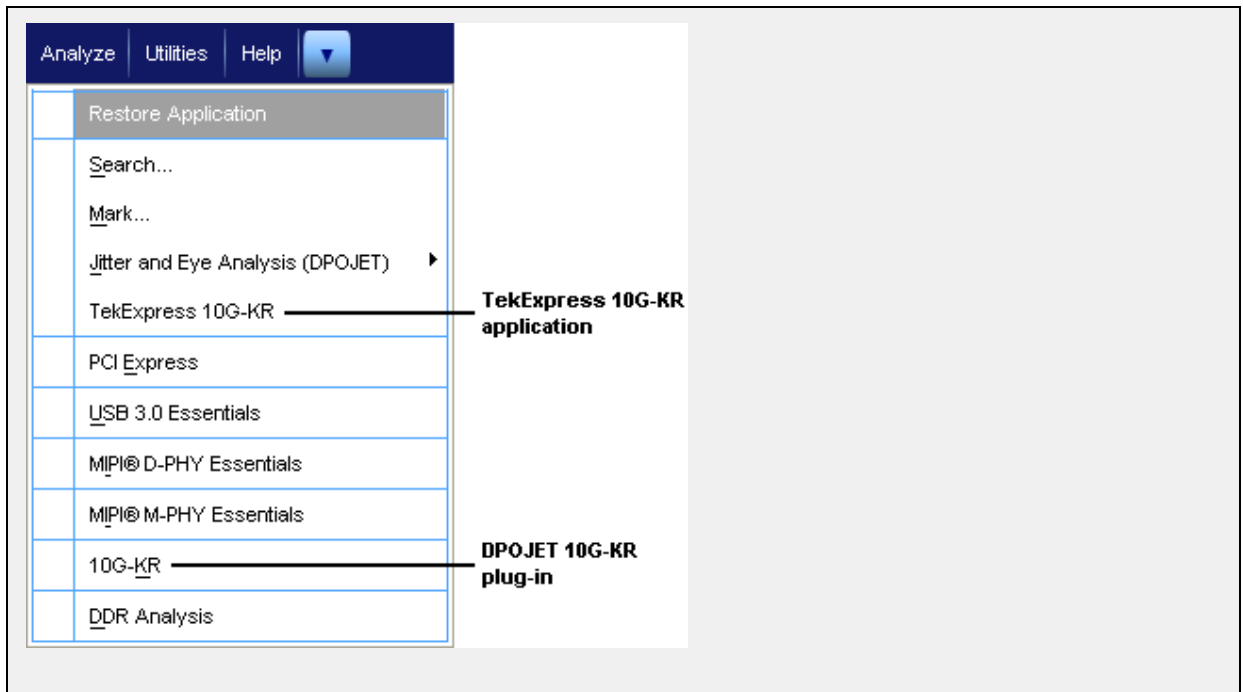

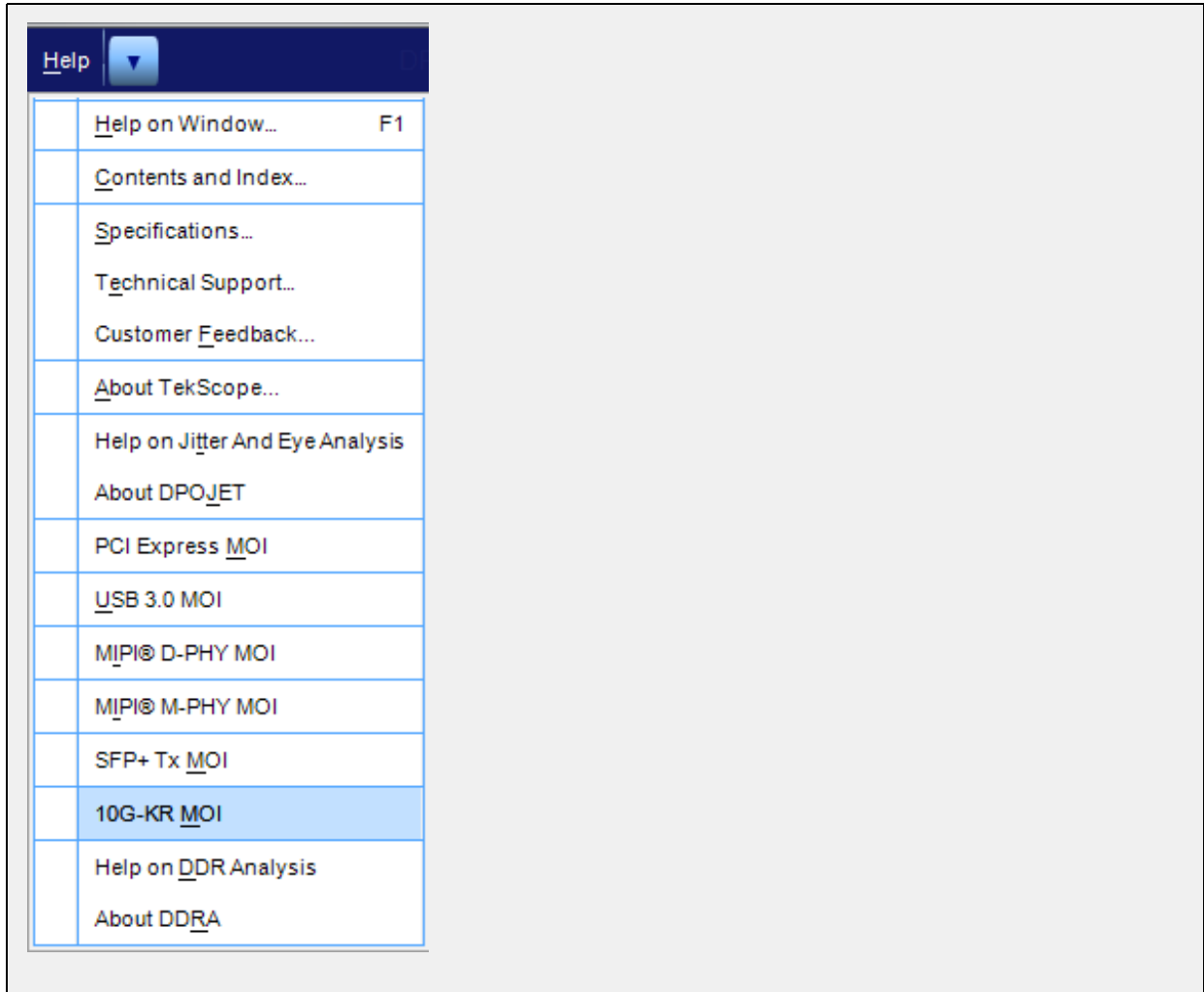

Using the DPOJET 10G-KR plug-in

1. In the TekScope Analyze menu, select 10G-KR. This launches DPOJET and displays the Select > Standard menu.

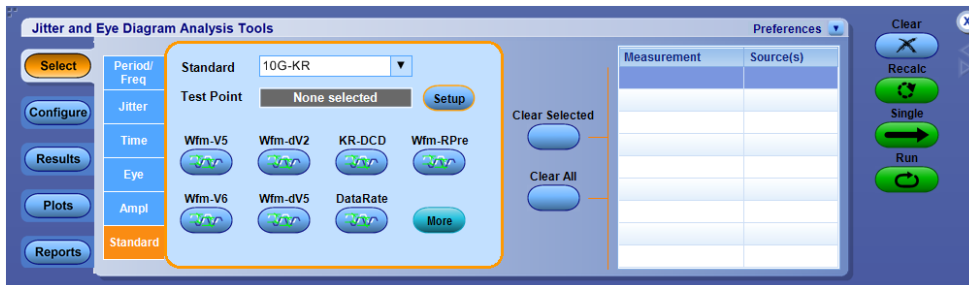

2. Click the Setup button. This opens a browsing window. Navigate to the 10G-KR folder in the DPOJET/Setups folder. 10G-KR setup files are pre-loaded during installation.

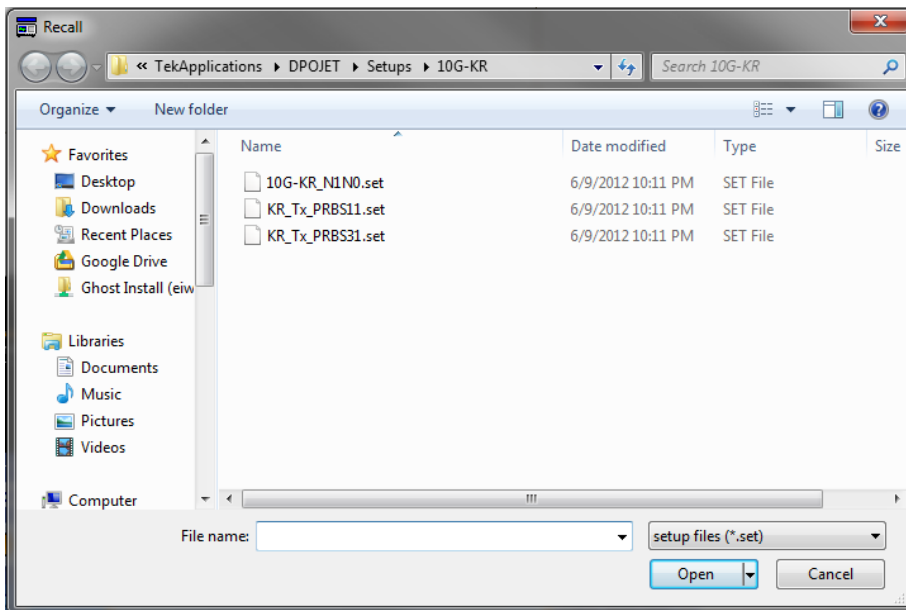

3. Select a setup file. selecting a setup file populates the Measurement and Source(s) window with the 10G-KR measurements based on the setup file selected.
4. Now you can use the DPOJET settings and configurations to make adjustments to the test parameters to meet your testing or debugging needs.

Refer to the TekScope online help for detailed information about using DPOJET.

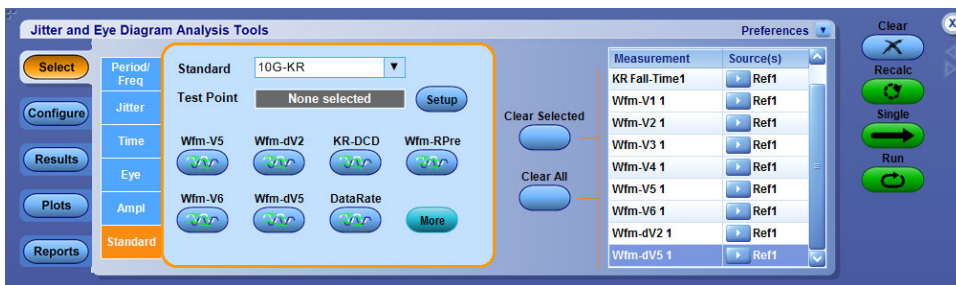

5. Select RUN to start the test.

Table 10: 10G-KR measurements map to DPOJET and 10G-KR DPOJET Plug-in measurements

10G-KR measurements	DPOJET and 10G-KR measurements (DPOJET Standard tab: Standard set to 10G-KR)	
72.7.1.3 Signaling speed	Standard tab:	Data rate
72.7.1.4 Differential peak-to-peak output voltage (max)	Standard tab:	Vpk-pk
72.6.5 Differential peak-to-peak output voltage (max) with Tx disabled		
72.7.1.7 Transition time	Standard tab:	KR Rise-Time KR Fall-Time

Table 10: 10G-KR measurements map to DPOJET and 10G-KR DPOJET Plug-in measurements (cont.)

10G-KR measurements	DPOJET and 10G-KR measurements (DPOJET Standard tab: Standard set to 10G-KR)	
72.7.1.8 Max output jitter (peak-peak)	Jitter tab:	RJ DJ TJ@BER
	Standard tab:	KR-DCD
72.7.1.10 Transmitter output waveform characteristics	Standard tab:	Square wave voltages: Wfm-V1
72.7.1.11a Output waveform coefficient update		Wfm-V2 Wfm-V3
72.7.1.11b Output waveform coefficient status		Wfm-V4 Wfm-V5 Wfm-V6 Wfm-dV2 Wfm-dV5
		(v1 + v4)/v1 ratio is measured by Wfm-V1V4R. (v2 + v5)/v2 ratio is measured by Wfm-V2V5R. (v3 + v5)/v3 ratio is measured by Wfm-V3V5R. Rpre and Rpst are measured by Wfm-RPre and Wfm-RPost respectively.

Map the My TekExpress folder

Follow these steps to map the My TekExpress folder on the instrument:

1. Open Windows Explorer.
2. From the Windows Explorer menu, click **Computer**.
3. In the menu bar, select **Map network drive**.
4. Select the Drive letter as **X:** (if there is any previous connection on X:, disconnect it first through **Tools > Disconnect Network drive** menu of Windows Explorer. Windows 7 users: if you do not see the Tools menu, press the **Alt** key).
5. In the Folder field, enter the remote My TekExpress folder path (for example, \\192.158.97.65\My TekExpress).

To determine the IP address of the instrument where the My TekExpress folder exists, do the following:

1. On the instrument where the My TekExpress folder exists, click **Start** and select **Run**.
2. Type “cmd” and then press **Enter**.
3. At the command prompt, type “ipconfig” and then press **Enter**.

See also

[Before you click start \(see page 49\)](#)

[Install the software \(see page 3\)](#)

Index

Symbols and Numbers

10G-KR application
 commands, 61
 10G-KR DPOJET plug-in
 using, 104
 10G-KR features, 7
 10G-KR option to DPOJET, 102

A

About TekExpress, 7
 Acquire live waveforms, 22
 Acquire parameters, 30
 including in test reports, 38
 showing, 28
 viewing in reports, 40
 Acquisition tab, 26
 Acquisitions table, 28
 Activate the license, 4
 Advanced View, 43
 Appending reports, 40
 Application controls, 14
 Application version, 6
 Application window
 moving, 14
 ApplicationStatus(), 82
 Automate RF switch, 26

C

Channel selection commands, 77
 CheckSessionSaved(), 88
 Command buttons, 14
 Commands, 61
 Comments, 22
 Compliance Mode, 43
 Compliance View, 43
 Configuration Parameter
 query, 74
 Configure button, 25
 Configure selected measurement
 commands, 78
 Configuring email notifications, 17
 Connect(), 68

Connected instruments
 searching for, 46
 Connection requirements, 44

D

De-embedding, 101
 Default directory, 10
 Deselect All button, 25
 Deskew channels, 101
 Detailed log view, 33
 Device parameters, 22
 Device profile connections, 44
 Device profiles, 22
 Directories, 10
 Disable popups command, 70
 Disconnect from server
 command, 90
 Disconnect(), 90
 DPOJET
 standard, 102
 DPOJET 10G-KR plug-in
 using, 104
 DPOJET option 10G-KR, 102
 DPOJET Plug-In, 3
 DUT ID, 22
 DUT ID commands, 71
 DUT parameters, 22
 DUT type
 10GBase-KR, 22
 40GBase-KR4, 22

E

Email notifications, 17
 Email settings, 16
 Equipment setup, 44
 Error code commands, 80
 Evaluation mode, 13
 Exiting the application, 13

F

Features, 7
 File name extensions, 12

Filter files, 101
 Flowchart for client programmatic
 interface, 56
 Free trials, 13

G

GetAcquireParameter(), 74
 GetAnalyzeParameter(), 74
 GetCurrentStateInfo(), 83
 GetDutId(), 71
 GetGeneralParameter(), 74
 GetPassFailStatus(), 84
 GetReportParameter(), 86
 GetResultsValue(), 84
 GetResultsValueForSubMeasure-
 ments(), 85
 GetTimeOut(), 81
 Global settings, 30

H

Help conventions, 1
 Host tests, 43

I

Installing the software
 DPOJET Plug-In, 3
 TekExpress application for
 10G-KR, 3
 Instruments
 discovering connected, 16
 viewing connected, 46
 Instruments detected, 30
 Interface, 55
 Interface error codes, 80
 IP address connection
 commands, 68

K

Keep On Top, 13
 Key, 13

- L**
- lanes, 26
- Lanes
 - number of, 22
- License, 13
- License activation, 4
- License agreement, 6
- Limits Editor, 30
- LockSession(), 69
- Log view
 - save file, 33
- Log view tab, 33
- M**
- Measurement limits, 30
- Measurement selection
 - commands, 75
- Menus, 14
- Mode
 - Compliance, 30
 - User Defined, 30
- Module tests, 43
- Moving the application
 - window, 14
- My TekExpress folder
 - files stored in, 37
 - location of, 49
 - mapping, 107
- N**
- Notifications, 29
- O**
- Options menu, 14
 - Instrument control settings, 16
 - Keep On Top, 13
- Oscilloscopes supported, 7
- Overall test result, 35
- Overview of 10G-KR, 7
- P**
- Panels, 21
- Pass/Fail summary
 - viewing, 40
- Pass/Fail Summary
 - including in reports, 39
- Plot images
 - including in reports, 39
 - viewing, 40
- Popups, 70
- Pre-recorded waveform files, 26
- Pre-run checklist, 51
- Preferences menu, 35
- Preferences tab, 21
- Prerecorded waveform files
 - selecting run sessions for, 22
- Probes, 28
- Program example, 59
- Programmatic interface, 55
- Q**
- QueryStatus(), 82
- R**
- Reactivate the license, 4
- Real time scope, 30
- RecallSession(), 88
- Record length, 30
- Refresh sources, 28
- Related documentation, 1
- Report name, 39
- Report options, 38
- Report sections, 40
- Reports, 40
 - adding user comments to, 22
 - receiving in email notifications, 17
- Reports panel, 37
- Resource file, 13
- Results panel, 35
- RF switch, 26
- Run commands, 79
- Run the application, 13
- Run(), 79
- S**
- Sampling rate, 101
- SaveSession(), 88
- SaveSessionAs(), 88
- Saving test setups, 53
- Saving tests, 37
- Schematic button, 25
- Select All button, 25
- Select Required button, 25
- Selecting test report contents, 38
- Selecting tests, 25
- SelectTest(), 76
- SendResponse(), 83
- Server, 55
- Server locking commands, 69
- Session files, 37
- Session folders, 37
- Session status commands, 88
- Set Configuration Parameters
 - commands, 72
- SetAcquireParameter(), 78
- SetAnalyzeParameter(), 78
- SetDutId(), 71
- SetGeneralParameter(), 72
- SetTimeout(), 81
- Setting up equipment, 44
- Setting up tests, 48
- Setup panel, 21
- Setup panel views, 22
- SetVerboseMode(), 70
- Show Acquire Parameters, 28
- Software installation, 3
- Software version, 6
- Sources, 28
- Start the application, 13
- Status panel, 33
- Stop commands, 79
- Stop(), 79
- Suite selection commands, 76
- Support, 2
- System requirements, 8
- T**
- Technical support, 2
- TekExpress application for 10G-KR, 3
- TekExpress client, 55
- TekExpress client requirements, 55
- TekExpress server, 55
- Test groups, 25
- Test notification preferences, 29
- Test parameters, 30
- Test reports, 40

- Test results
 - emailing, 17
 - Test results commands, 84
 - Test selection controls, 25
 - Test setup files, 37
 - Test setup steps, 48
 - Test setups, 53
 - creating, 54
 - recalling, 54
 - saving, 53
 - Test status commands, 81
 - Test status tab, 33
 - Test-related files, 37
 - Tests
 - running, 49
 - selecting, 25
 - setting up, 43
 - TestStand Client example, 61
 - Timeout Value commands, 81
 - TransferImages(), 87
 - TransferReport(), 86
 - TransferWaveforms(), 87
- U**
- Unlock server command, 89
 - UnlockSession(), 89
 - Untitled session folder, 49
 - User comments
 - location in reports, 40
- User Comments**
including in reports, 40
- User Defined Mode, 43
- V**
- View probes, 28
- W**
- Waveform files
 - locating and storing, 37