

STC-37 Screw Terminal Connector

WARNING

This screw terminal connector is not intended for use in circuits carrying voltages in excess of 30V RMS, 42.4V peak, or 60VDC.

Description

The STC-37 provides screw terminals directly at the rear of any data acquisition board having a 37-pin D connector. Each of the 37 pins is connected directly to a screw terminal labeled with the pin number. See Figure 1 below.

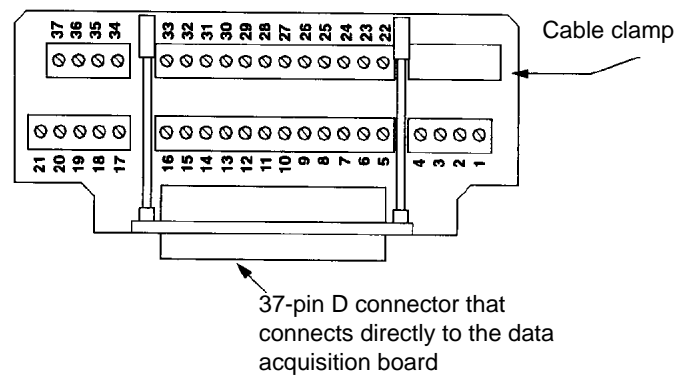

Figure 1. Layout of STC-37 screw terminal connector

Specifications

Voltage: 30V RMS, 42.4V peak, or 60VDC
Current: 1A maximum
Screw terminal wire size: 12-22 AWG

Safety precautions

The following safety precautions should be observed before using this product and any associated instrumentation. Although some instruments and accessories would normally be used with non-hazardous voltages, there are situations where hazardous conditions may be present.

This product is intended for use by qualified personnel who recognize shock hazards and are familiar with the safety precautions required to avoid possible injury. Read the operating information carefully before using the product.

General safety definitions

The types of product users are:

Responsible body is the individual or group responsible for the use and maintenance of equipment, and for ensuring that operators

are adequately trained.

Operators use the product for its intended function. They must be trained in electrical safety procedures and proper use of the instrument. They must be protected from electric shock and contact with hazardous live circuits.

Maintenance personnel perform routine procedures on the product to keep it operating, for example, setting the line voltage or replacing consumable materials. Maintenance procedures are described in the manual. The procedures explicitly state if the operator may perform them. Otherwise, they should be performed only by service personnel.

Service personnel are trained to work on live circuits, and perform safe installations and repairs of products. Only properly trained service personnel may perform installation and service procedures.

If a grounding screw  is present, connect it to safety earth ground using the wire recommended in the user documentation.

The  symbol on an instrument indicates that the user should refer to the operating instructions located in the manual.

The WARNING heading in a manual explains dangers that might result in personal injury or death. Always read the associated information very carefully before performing the indicated procedure.

The CAUTION heading in a manual explains hazards that could damage the instrument. Such damage may invalidate the warranty.

Installation safety

As described in the International Electrotechnical Commission (IEC) Standard IEC 664, the signal terminals are Installation Category I and must not be connected to mains.

Do not connect switching cards directly to unlimited power circuits. They are intended to be used with impedance limited sources. NEVER connect switching cards directly to AC mains. When connecting sources to switching cards, install protective devices to limit fault current and voltage to the card.

Operators and maintainers of this product must be protected from electric shock at all times. The responsible body must ensure that users are prevented access and/or insulated from every connection point. In some cases, connections must be exposed to potential human contact. Product users in these circumstances must be trained to protect themselves from the risk of electric shock. If the circuit is capable of operating at or above 1000 volts, no conductive part of the circuit may be exposed.

Operation safety

Exercise extreme caution when a shock hazard is present. Lethal voltage may be present on cable connector jacks or test fixtures. The American National Standards Institute (ANSI) states that a shock hazard exists when voltage levels greater than 30V RMS, 42.4V peak, or 60VDC are present. A good safety practice is to expect that hazardous voltage is present in any unknown circuit before measuring.

For maximum safety, do not touch the product, test cables, or any other instruments while power is applied to the circuit under test. ALWAYS remove power from the entire test system and discharge any capacitors before: connecting or disconnecting cables or jumpers, installing or removing switching cards, or making internal changes, such as installing or removing jumpers.

Do not touch any object that could provide a current path to the common side of the circuit under test or power line (earth) ground. Always make measurements with dry hands while standing on a dry, insulated surface capable of withstanding the voltage being measured.

Do not exceed the maximum signal levels of the instruments and accessories, as defined in the specifications and operating information, and as shown on the instrument or test fixture panels, or switching card.

If you are using a test fixture, keep the lid closed while power is applied to the device under test. Safe operation requires the use of a lid interlock.

Instrumentation and accessories shall not be connected to humans.

Maintenance and service for safety

Inspect the connecting cables, test leads, and jumpers for possible wear, cracks, or breaks before each use.

Before performing any maintenance, disconnect all power sources and test cables.

Cleaning

Keep the connections free of contaminants (such as dirt, oil, etc.) in order to maintain maximum insulation resistance. If the connections become contaminated, clean them thoroughly with methanol and allow them to dry completely before use.

Installation

Install the STC-37 on the data acquisition board as shown in Figure 2. Be sure to secure the connector to the board by tightening the jack screws.

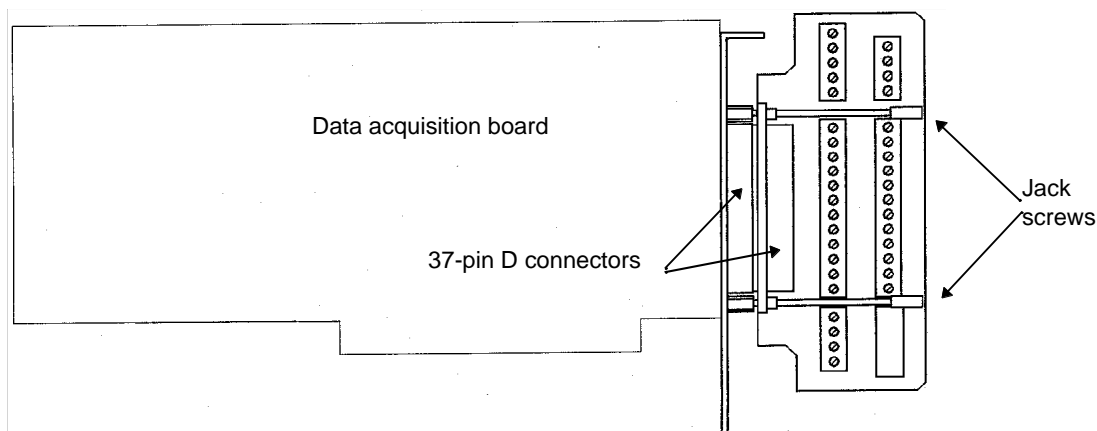

Figure 2. STC-37 connector installation